

Mutina

**Mutina
In-Between
Art and
Design**

Mutina In-Between Art and Design

Da oltre dieci anni, Mutina promuove un percorso di valorizzazione della materia ceramica che unisce design e arte, in un processo di sperimentazione e contaminazione reciproca.

Lavorare fianco a fianco con designer, architetti e artisti, osservarli, sostenerli è da sempre il motore dell'azienda. Lo scambio – creativo, progettuale, umano – che ne deriva ha un impatto fondamentale su tutti i progetti che prendono vita in Mutina, che si tratti di una collezione di rivestimenti ceramici, di una mostra collettiva di arte contemporanea o di una collaborazione su un grande progetto architettonico.

In questo senso, quella di Mutina è una storia fatta di incontri. Quello, fondamentale, tra i fondatori del marchio che, in un momento in cui tutti seguivano una rotta, hanno deciso di voltarsi e andare controvento; quello con i designer che, abbracciando una visione del tutto inedita e sperimentale, hanno preso il rischio di lavorare su una materia spesso alterata per riportarla alla sua vera essenza; quello con il mondo dell'arte, che ha sempre rappresentato un linguaggio intrinseco e un riferimento fondamentale, evolvendosi poi in un progetto variegato e visionario come Mutina for Art.

Mutina è quindi il risultato di tutti questi incontri, voluti, ricercati, ma non solo. Dare una definizione netta, senza dar spazio a sfumature o a finali in divenire, significherebbe sostanzialmente circoscrivere a priori l'entità del progetto su un piano concettuale. Significherebbe tradire l'essenza stessa di Mutina, che non ha mai voluto auto-definirsi ma è nata al contrario da una sfida destinata a perdurare nel tempo; perchè è sempre bello guardare al futuro con gli occhi di chi sa che grandi cose possono nascere dal presente che si sta costruendo. Questa è forse la ragione per cui, prima di ogni cosa, Mutina ricerca e promuove la bellezza, nella forma più pura del suo essere: quel particolare capace di appagare l'animo attraverso i sensi, divenendo oggetto di assorta contemplazione.

For over ten years, Mutina has been promoting an enhancement process of the ceramic matter that combines design and art, in a course of experimentation and mutual contamination.

Working side by side with designers, architects and artists, observing them, supporting them has always been the driving force of the company. The resulting exchange – creative, design-driven, human – has a fundamental impact on all the projects that come to life in Mutina, whether it is a collection of ceramic wall tiles, a group exhibition of contemporary art or a collaboration on a large-scale architectural project.

In the end, Mutina's is a story made up of encounters. The fundamental one among the founders of the brand who, at a time when everyone was following a course, decided to turn around and go against the wind; the one with the designers who embraced a completely new and experimental vision, taking the risk of working on an often altered material to bring it back to its true essence; the one with the art world, which has always represented an intrinsic language and a fundamental reference, eventually evolving into a varied and visionary project such as Mutina for Art.

Mutina is therefore the result of all these encounters, deeply wanted and sought after, but not only. Giving a clear definition, without leaving room for nuances or unfinished endings, would essentially mean limiting the entity of the project a priori on a conceptual level. It would mean betraying the very essence of Mutina, which never wanted to define itself but was born from a challenge destined to last over time; because it's always nice to look to the future with the eyes of someone who knows that great things can arise from the present. This is perhaps the reason why, before everything else, Mutina seeks and promotes beauty, in the purest form of its being: that detail capable of satisfying the soul through the senses, becoming the object of absorbed contemplation.

ABOUT MUTINA
8

TILES
61

3D ELEMENTS
297

EDITIONS
335

PAINTS
365

WOOD & METAL
379

ACCESSORIES
397

TECHNICAL FEATURES
407

Collections

Tiles
3D Elements
Editions
Paints
Wood & Metal
Accessories

Tiles

Le collezioni Mutina sono frutto di una continua ricerca sulle tecnologie più avanzate, per produrre rivestimenti ceramici che vestano le architetture come una seconda pelle. Ogni progetto nasce e prende forma attraverso un incessante dialogo fra l'azienda e il suo team di designer, con l'obiettivo di valorizzare a pieno la materia ceramica, sperimentando un'infinita gamma di texture e colori, dai toni neutri e delicati a quelli più audaci e vibranti.

The Mutina collections come about from the continuous research on the most advanced technologies, to produce ceramic tiles that adapt to architecture like a second skin. Each project results and takes shape through an ongoing dialogue between the company and its team of designers, with the aim of bringing out the best in ceramic material, experiencing the endless range of textures and colours, spacing from delicate and natural shades to the most bold and vibrant ones.



Patricia Urquiola, Déchirer

Con i suoi bassorilievi, ha segnato una vera rivoluzione nel campo dei rivestimenti ceramici d'autore.
With its bas-reliefs, it marked a real revolution in the field of designer ceramic coverings.

Tokujiin Yoshioka, Phenomenon

La ceramica diventa materia duttile per riprodurre e incorporare i fenomeni e le leggi della natura.
Ceramic becomes a ductile material to reproduce and incorporate the phenomena and laws of nature.

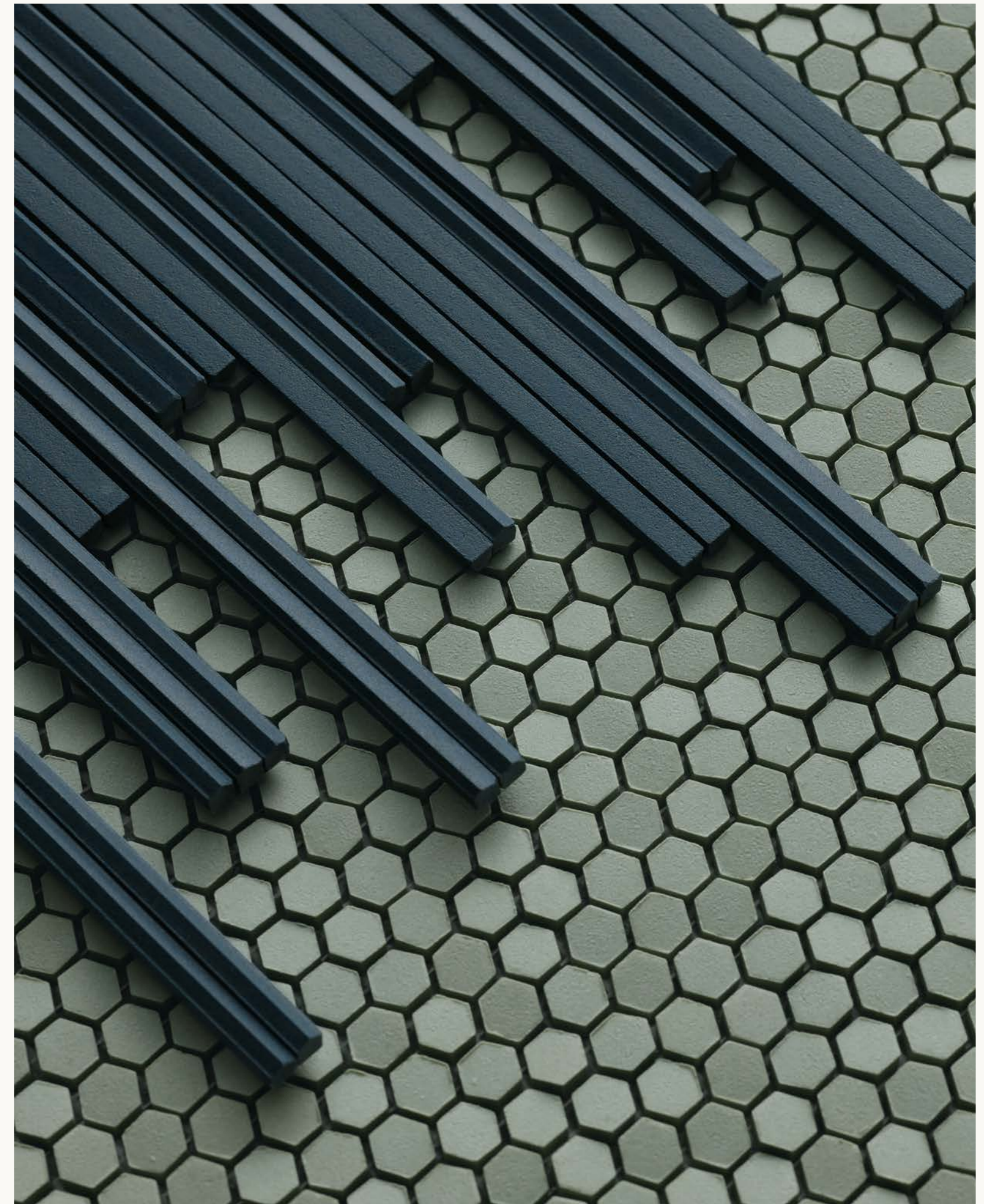



Ronan & Erwan Bouroullec, Punto

Un elemento decorativo tridimensionale, pensato per essere utilizzato a rivestimento.
A three-dimensional decorative element, designed to be used as a wall covering.



Vincent Van Duysen, Kosei

Un progetto ceramico che riproduce la durezza e la porosità delle rocce laviche, grazie all'utilizzo di materiali puri e tattili.
A ceramic project that reproduces the hardness and porosity of lava rocks, thanks to the use of pure and tactile materials.

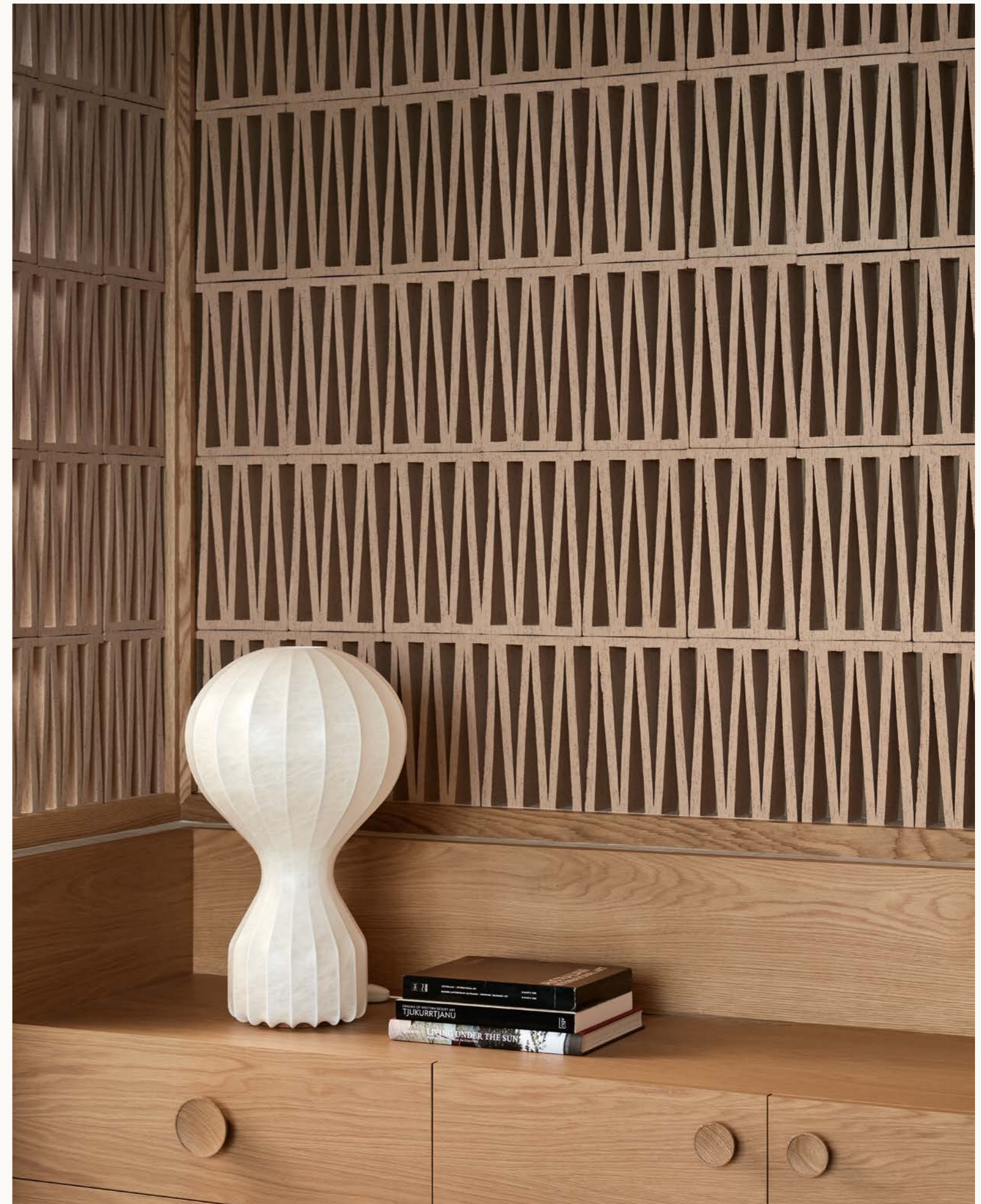
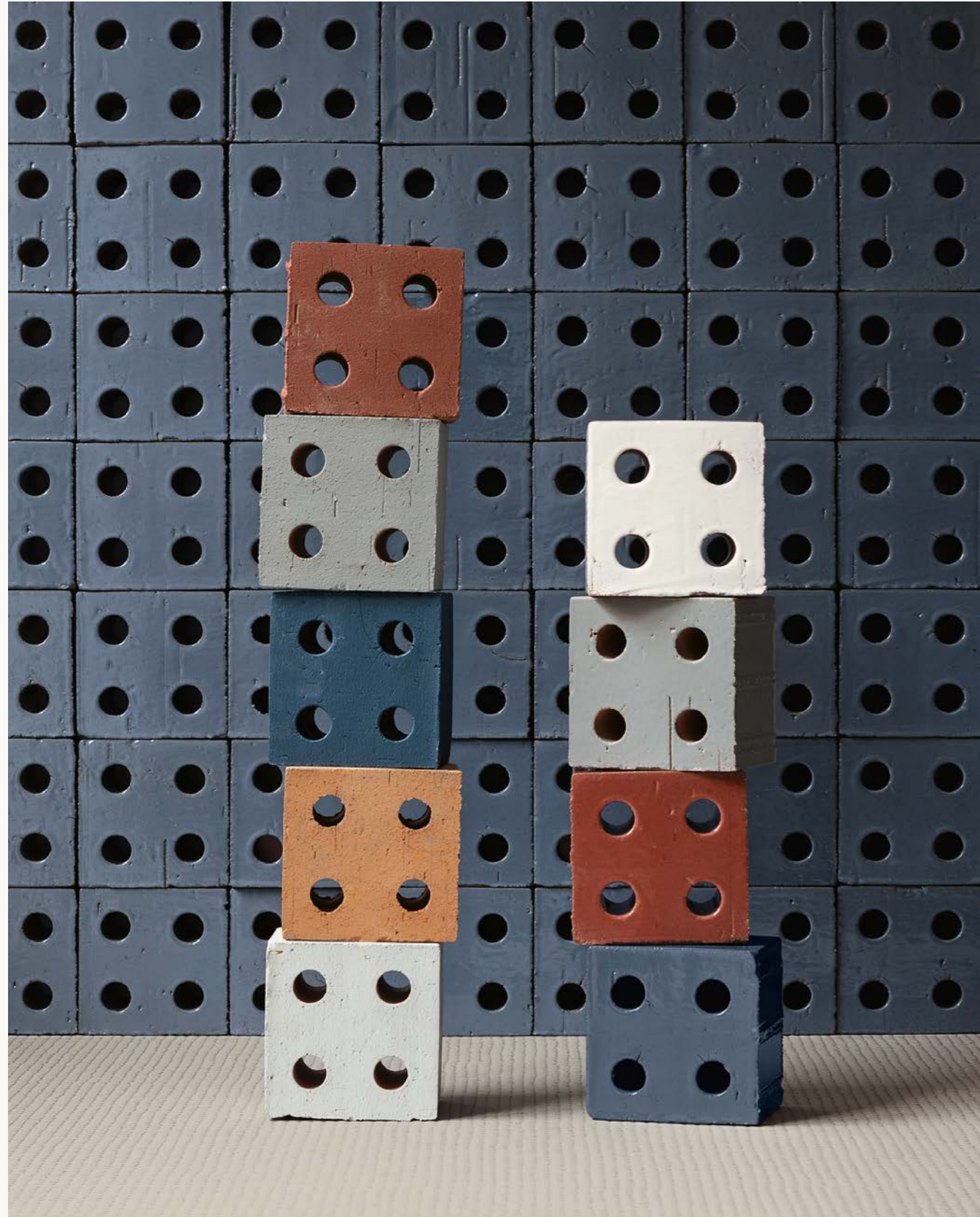

Editions

Le Editions sono collezioni di oggetti in ceramica legati al mondo degli interni d'autore, interamente fatti a mano e realizzati esclusivamente in Italia secondo la tradizione artigianale. Manufatti progettati dai designer e dagli artisti del team Mutina, prodotti da abili maestri ceramisti. Ogni pezzo viene timbrato e firmato in maniera sequenziale, per sottolinearne l'esclusività: sono creazioni uniche destinate a durare nel tempo e a raggiungere ogni angolo del mondo, ma solo una per volta.

The Editions are collections of ceramic objects linked to the world of auteur interiors, realised exclusively in Italy and entirely handcrafted according to the artisanal tradition. Artifacts developed by the designers and artists of the Mutina team, produced by skillful master potters. Each piece is stamped and signed in a sequential manner to enhance its exclusivity: they are unique creations meant to last and to reach every corner of the world, but only one by one.



Ronan & Erwan Bouroullec, Rombini Vases



Previous page – Nathalie Du Pasquier, Paesaggi
Vincent Van Duysen, Yama

Paints

Le pitture Mutina sono pensate appositamente per accompagnare i rivestimenti ceramici dell'azienda, sia in termini di palette che di finish, e si dividono in due collezioni: Accents Paints di OEO Studio, con 25 proposte colore nelle finiture Matt e Satin e 6 nella variante Limetouch, e Margherita Paints di Nathalie Du Pasquier, con 5 colorazioni disponibili nelle finiture Matt e Satin.

Mutina paints have been specifically developed to be paired with the ceramic tiles of the company, both in terms of palette and finish, and feature two collections: Accents Paints by OEO Studio, including 25 colours declined in the variants Matt and Satin and 6 in the Limetouch finish, and Margherita Paints by Nathalie Du Pasquier, featuring 5 colours available in Matt and Satin finishes.

Rosa, Verde, Arancione, Azzuro: some of the nuances of Margherita Paints by Nathalie Du Pasquier

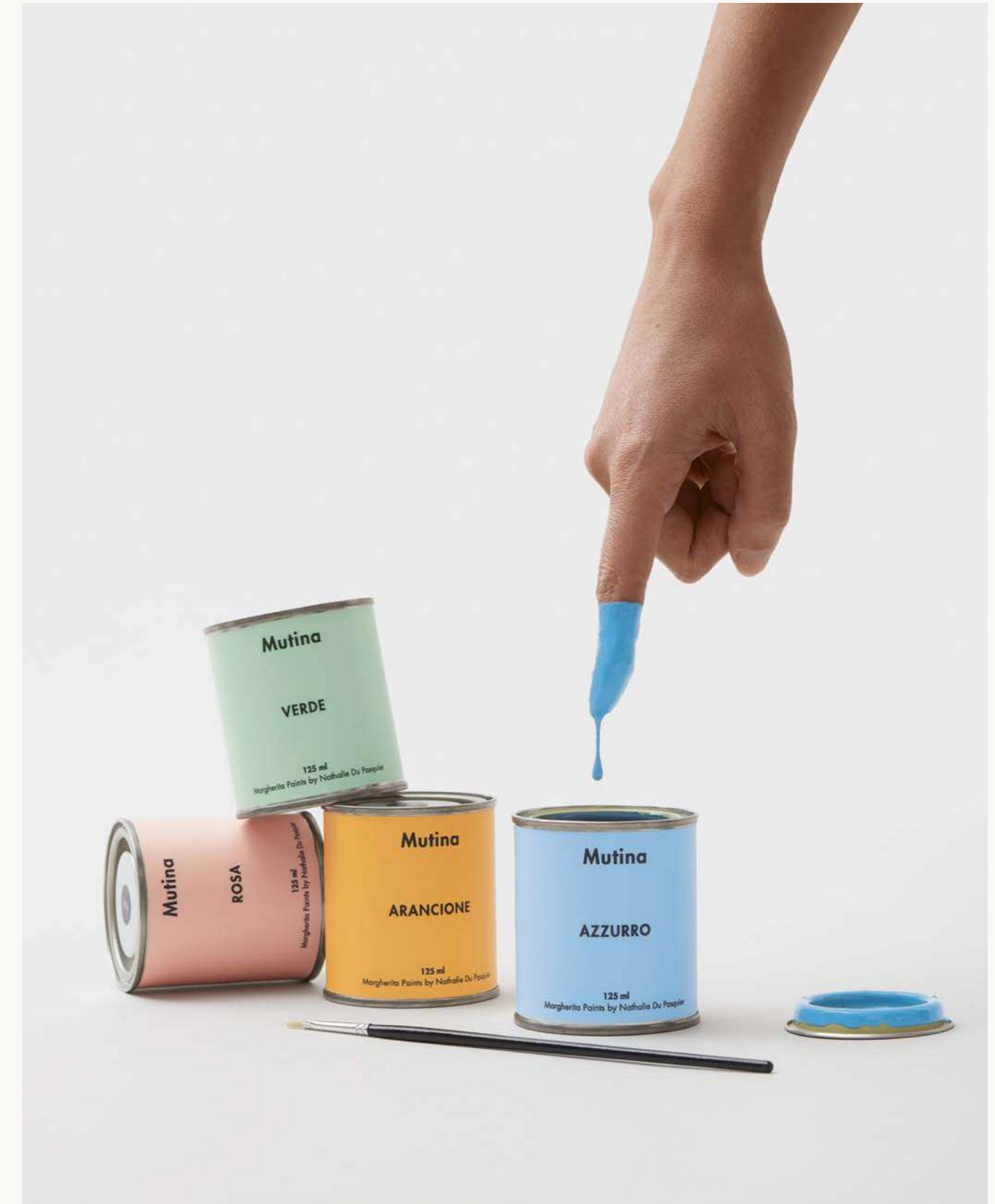

Wood & Metal

Negli anni, Mutina ha intrapreso progetti che vedono protagonisti materiali come legno e metallo. L'azienda propone Accents, una collezione di elementi progettati da OEO Studio, pensati per interagire con le superfici ceramiche, e un nuovo pavimento in parquet disegnato da Ronan ed Erwan Bouroullec: Pico Bois.

Over the years, Mutina embarked projects featuring materials such as wood and metal. The company offers Accents by OEO Studio, a range of elements designed to interact with ceramic surfaces, and a new parquet flooring by Ronan and Erwan Bouroullec: Pico Bois.



Mutina Interiors nasce nel 2019 con l'obiettivo di suggerire uno stile di progettazione a partire dalle ceramiche del brand, utilizzate in modo trasversale e combinate tra loro per creare interni originali e distintivi, che rispecchiano lo spirito dell'azienda.

Le suggestioni proposte – estremamente variegata in termini di approccio creativo e look & feel – vengono completate da elementi in legno e metallo, pitture e piccoli complementi d'arredo di alta qualità, come quelli appartenenti alle collezioni Accessories, Editions, Paints e Wood & Metal. I prodotti dialogano con le superfici in modo del tutto nuovo e armonioso, creando un gioco di contrasti, tattilità e sfumature che valorizza a pieno le superfici Mutina, sia a pavimento che a rivestimento.

In questo modo, l'azienda fornisce delle ispirazioni per la realizzazione di ambienti completi e funzionali dal gusto contemporaneo, sottolineando la versatilità delle sue collezioni attraverso lo sviluppo di soluzioni progettuali inedite.

Mutina Interiors was born in 2019 with the aim of suggesting a design style starting from the ceramics of the brand, here used in a transversal way and combined to create original and distinctive spaces, that reflects the spirit of the company.

The featured suggestions – extremely diversified in terms of creative and look & feel – are refined with wooden and metal elements, paints and furnishings of high quality, like those from the Accessories, Editions, Paints and Wood & Metal collections. The products dialogue with the surfaces in a completely new and harmonious way, creating a play of contrasts, textures and colours that enhances Mutina surfaces to the fullest, on both floors and walls.

In this way, the company provides inspirations to realise complete and functional interiors of contemporary taste, highlighting the versatility of its collections with the development of unprecedented design solutions.







BARBER & OSGERBY

Edward Barber e Jay Osgerby sono entrati a far parte del team Mutina nel 2013 con la collezione Mews. Hanno poi rinnovato la collaborazione con Puzzle e Mistral, e lanciato Lane e Primavera nel 2018. Barber e Osgerby inaugurano il loro studio londinese nel 1996, dopo essersi laureati al Royal College of Art di Londra. Il loro approccio multidisciplinare sfida i confini del design industriale, dell'architettura e dell'arte. I loro lavori includono collezioni per Knoll, Vitra, B & B Italia, Cappellini, Venini e Flos, limited edition e commissioni pubbliche. La prima monografia estensiva loro dedicata, pubblicata da Rizzoli New York, è del 2011. Entrambi sono Royal Designers for Industry e Honorary Doctors of Art. Il loro lavoro è nelle collezioni permanenti di musei in tutto il mondo, come il V&A e il Design Museum di Londra, il Metropolitan Museum of Art di New York o l'Art Institute di Chicago.

Edward Barber and Jay Osgerby joined the Mutina team in 2013 with the Mews collection. They renovated the collaboration with Puzzle and Mistral, and launched Lane and Primavera in 2018. Barber and Osgerby opened their London-based studio in 1996, after graduating from the Royal College of Art. Their multidisciplinary approach pushes the boundaries of industrial design, architecture and art. Their works include collections for Knoll, Vitra, B&B Italia, Cappellini, Venini and Flos, limited edition pieces and commissions. The first extensive monograph on the pair was published by Rizzoli New York in 2011. They are both Royal Designers for Industry and Honorary Doctors of Art. Their work is included in the permanent collections of museums all around the world, such as V&A and Design Museum in London, the Metropolitan Museum of Art in New York and Chicago's Art Institute.

RONAN & ERWAN BOURULLEC

Ronan e Erwan Bouroullec, designer originari della Bretagna, sono entrati a far parte del team Mutina nel 2011. Hanno firmato le collezioni Pico, Rombini, Punto, Pico Bois, Bloc e Rombini Vases. La collaborazione tra Ronan e Erwan Bouroullec si sviluppa come un dialogo permanente alimentato dalle loro personalità molto diverse. Lavorano con numerose aziende, tra cui Cappellini, Established & Sons, Flos, Hay, Kvadrat, Ligne Roset Magis, Nanimarquina, e Vitra, e intraprendono spesso occasionali progetti d'architettura urbana. Allo stesso tempo, portano avanti un'attività di sperimentazione presso la Galerie Kreo di Parigi. Molti i premi al loro attivo: il Compasso d'Oro nel 2011, London Design Medal nel 2014, The Design Prize e il premio ufficiale della città di Milano come migliori designer nel 2017. Numerose mostre sono state dedicate al loro lavoro e le loro creazioni sono parte delle collezioni permanenti di diversi musei internazionali.

Ronan and Erwan Bouroullec, designers originally from Brittany, joined the Mutina team in 2011. They designed Pico, Rombini, Punto, Pico Bois, Bloc and Rombini Vases. The collaboration between Ronan and Erwan Bouroullec develops as a permanent dialogue nourished by their distinct personalities. They design for many editors, including Cappellini, Established & Sons, Flos, Hay, Kvadrat, Ligne Roset Magis, Nanimarquina, and Vitra, often embark on occasional urban designs. They simultaneously continue their experimental activity at Galerie Kreo in Paris. Their work has been recognised with many awards, including the Compasso d'Oro, 2011, the London Design Medal, 2014, The Design Prize and the City of Milan official award, for best Designers, 2017. Several exhibitions have

showcased their works and their creations are part of the permanent collections of several international museums.

NATHALIE DU PASQUIER

Artista e designer di origini francesi, Nathalie Du Pasquier si è unita al team Mutina nel 2019 con la realizzazione di BRIC, l'installazione site-specific esposta in occasione di MUT 4. Ha progettato la serie di elementi 3D Brac, le collezioni Mattonelle Margherita e Paesaggi, e le Margherita Paints. Nathalie Du Pasquier è nata a Bordeaux nel 1957 e vive a Milano dal 1979. Negli anni ottanta ha lavorato come designer, progettando soprattutto tessuti e superfici, ed è stata tra i fondatori del gruppo Memphis. Dal 1987, si dedica prevalentemente alla pittura, un ambito in cui la sua pratica ha preso direzioni inaspettate ed è stata oggetto di una costante evoluzione. Il suo lavoro è stato esposto in mostre personali presso: Kunsthalle Wien, International Center of Graphic Arts di Ljubljana, Galerie Fuer Zeitgenoessische Kunst di Lipsia, Apalazzo Gallery di Brescia, Pace Gallery di Seoul e Anton Kern Gallery di New York.

French artist and designer Nathalie Du Pasquier joined the Mutina team in 2019 with the realisation of BRIC, site-specific installation exhibited on the occasion of MUT 4. She designed Brac, a series of three-dimensional elements, the Mattonelle Margherita and Paesaggi collections, as well as the Margherita Paints. Nathalie Du Pasquier was born in Bordeaux in 1957 and has lived in Milano since 1979. During the eighties, she has worked as a designer, creating textiles and mostly surfaces, and was a founding member of Memphis. In 1987 painting became her main activity and ever since her practice is constantly developing in new and unexpected directions. Her work has been featured in solo exhibitions at Kunsthalle Wien, International Center of Graphic Arts in Ljubljana, Galerie Fuer Zeitgenoessische Kunst in Leipzig, Apalazzo Gallery in Brescia, Pace Gallery in Seoul and at Anton Kern Gallery in New York.

KONSTANTIN GRICIC

Artista e designer di origini tedesche, Konstantin Grcic è entrato a far parte del team Mutina nel 2015. Ha firmato le collezioni DIN nel 2021 e Hives nel 2022. Dopo gli studi Design al Royal College of Art di Londra, Konstantin Grcic ha aperto il proprio studio di design a Monaco di Baviera nel 1991, dove ha sviluppato mobili, prodotti e illuminazione per Authentics, BD Ediciones, ClassiCon, Flos, Flötotto, Magis, Maharam, Muji, Nespresso, Plank, Serafino Zani e Vitra. Molti dei suoi prodotti hanno ricevuto premi internazionali, come il prestigioso Compasso d'Oro per la sua lampada Mayday (Flos) nel 2001 e la sedia Myto (Plank) nel 2011, oltre a far parte delle collezioni permanenti dei più importanti musei di design. La Royal Society for the Arts ha nominato Konstantin Grcic Royal Designer for Industry nel 2009, mentre Design Miami gli ha conferito il premio Designer of the Year per il 2010.

German artist and designer, Konstantin Grcic joined the Mutina team in 2015. He designed DIN in 2021 and Hives in 2022. After studying designed at the Royal College of Art in London, Konstantin Grcic opened his own studio in Munich in 1991, where he developed furniture, products and lighting for Authentics, BD Ediciones, ClassiCon, Flos, Flötotto, Magis, Maharam, Muji, Nespresso, Plank, Serafino Zani and Vitra. Many of his products received international design awards, such as the prestigious Compasso d'Oro for his Mayday lamp (Flos) in 2001 and the Muto

chair (Plank) in 2011, furthermore they are part of the permanent collections of the most important design museums. The Royal Society for the Arts appointed Konstantin Grcic Royal Designer for Industry in 2009, while Design Miami awarded him Designer of the Year in 2010.

HELLA JONGERIUS

Hella Jongerius, designer e ricercatrice instancabile, si è unita al team Mutina nel 2018. Ha progettato la collezione Diarama. Nata in Olanda ma con base a Berlino, Hella Jongerius è conosciuta per la sua ricerca su colori e materiali in continua evoluzione. Nel 1993 ha fondato Jongeriuslab, dove porta avanti progetti indipendenti e collaborazioni con importanti aziende del settore. Nel 2017 ha ricevuto il Sikkens Prize, grazie al suo speciale contributo nel campo dei colori. Molte delle sue creazioni, inoltre, si trovano nelle collezioni permanenti di alcuni famosi musei, come il MoMA, Victoria and Albert Museum e il Boijmans van Beuningen Museum.

Designer and tireless researcher Hella Jongerius joined the Mutina team in 2018. She designed the Diarama collection. Born in the Netherlands but based in Berlin, Hella Jongerius is well known for her never-ending colour and material research. She founded Jongeriuslab in 1993, where both independent projects and works for major clients are developed. In 2017, Jongerius received the Sikkens Prize, thanks to her special contribution to the field of color. Furthermore, many of her products can be found in the permanent collections of important museums, such as MoMA, Victoria and Albert Museum and Boijmans van Beuningen Museum.

LABORATORIO AVALLONE

La collaborazione tra Laboratorio Avallone e il team Mutina è iniziata nel 2019, con lo sviluppo della collezione Chymia e The Cylinder Glass, il primo progetto in edizione limitata dell'azienda con un focus sul vetro di Murano. La ricerca di Laboratorio Avallone si sviluppa sul terreno multidisciplinare delle arti applicate, dove coniuga i linguaggi di pittura e scultura per dare vita a oggetti e componenti d'arredo unici e speciali. Epicentro creativo del team è Gennaro Avallone, maestro e sperimentatore, che da più di venticinque anni esplora i confini e le possibilità delle superfici, portando avanti uno studio rivolto all'eccellenza.

The collaboration between Laboratorio Avallone and Mutina team begun in 2019, developing Chymia collection and The Cylinder Glass, the first company's limited edition project that focuses on Murano glass. The research carried out by Laboratorio Avallone reaches into the applied arts, drawing on the arts of painting and sculpture to create unique and very special objects of contemporary furnishing. The epicentre of the design team is Gennaro Avallone, a master and experimenter, who for over twenty-five years has been continually exploring the limits and possibilities of surfaces with meticulous research that strives to create excellence.

OEO STUDIO

La collaborazione tra OEO Studio e il team Mutina è iniziata nel 2018, con lo sviluppo di Accents: collezione di elementi architettonici, complementi d'arredo e pitture che affiancano le ceramiche del brand. Fondato nel 2003 a Copenhagen da Thomas Lykke e Anne-Marie Buemann, OEO Studio si distingue per le proprie doti eclettiche e la

forte connessione tra design e artigianato. Qualità che, combinate allo sguardo sempre rivolto al contesto internazionale e alla forte capacità di intuire le necessità del cliente, diventano essenziali nella realizzazione di progetti di architettura d'interni, design di prodotto e brand innovation.

The collaboration between OEO Studio and Mutina team started in 2018, developing Accents: a collection of architectural elements, complementary products and paints, accompanying the ceramics of the brand. Founded in 2003 by Thomas Lykke and Anne-Marie Buemann, the Copenhagen-based OEO Studio stands out for its eclecticism and strong passion for design and craft. These qualities, combined with a global outlook and the great ability to understand the client's needs, become fundamental to realise interior architecture, product design and brand innovation projects.

RAW EDGES

Raw Edges, design studio fondato da Yael Mer e Shay Alkalay, è entrato a far parte del team Mutina nel 2010. Hanno disegnato le collezioni Folded, Tex, Folded XL e Tape. Nati a Tel Aviv, Yael Mer e Shay Alkalay si sono spostati a Londra, dove hanno fondato il Raw Edges Design Studio. I loro diversi approcci convergono nella creazione di progetti inediti, frutto di una spiccata sensibilità ambientale. Nel 2009 hanno ricevuto l'Elle Decoration International Design Award per Stack di Established & Sons e sono stati insigniti del Designers of the Future Award al Design Miami/Basel. Collaborano con diversi brand internazionali come Cappellini, Established & Sons, Moroso, Kvadrat, Stella McCartney, Arco, Golran, Moustache e Lema. I loro lavori sono presenti nelle collezioni permanenti di musei internazionali.

The Raw Edges design studio, founded by Yael Mer and Shay Alkalay, joined the Mutina team in 2010. They designed the Folded, Tex, Folded XL and Tape collections. Both born in Tel Aviv, Yael Mer and Shay Alkalay moved to London, where they founded the Raw Edges Design Studio. Their different approaches combine in the creation of original projects, characterised by a keen sensitivity towards the environment. In 2009, they received the Elle Decoration International Design Award for Stack by Established & Sons and the Designers of the Future Award at Design Miami/Basel. They work with many international brands such as Cappellini, Established & Sons, Moroso, Kvadrat, Stella McCartney, Arco, Golran, Moustache and Lema. Their creations are part of the permanent collections at international museums.

INGA SEMPÉ

L'artista-designer Inga Sempé è entrata a far parte del team Mutina nel 2014. Inga Sempé è nata a Parigi da una famiglia di artisti. Diplomata nel 1993 all'ENSCI Atelier (Ecole Nationale Supérieure de Création Industrielle – Parigi), ha lavorato in diversi studi di design e di architettura d'interni per poi aprire il suo studio a Parigi nel 2000. Dal 2000 al 2001 presso Villa Medici (Academie de France) a Roma ha sviluppato i suoi primi progetti personali poi prodotti da Edra e Cappellini. Nel 2003 ha ottenuto il Grand Prize of Creation di Parigi per il design e ha esposto i suoi progetti in una mostra personale presso il Musée des Arts Décoratifs. La designer collabora con Ligne Roset, LucePlan, Wästberg, Moustache, Alessi, Almedahls, Hay, Svenkst Tenn e Cassina.

Artist and designer Inga Sempé joined the Mutina team in 2014. Inga Sempé was born in Paris into a family of artists. After graduating from the ENSCI Atelier (Ecole Nationale Supérieure de Création Industrielle – Paris) in 1993, she worked in various design and interior architecture studios, and opened her own Paris-based studio in 2000. From 2000 to 2001, Sempé designed her first personal projects produced by Edra and Cappellini at the Villa Medici (Academie de France) in Rome. In 2003, she received the Paris Grand Prize of Creation for design and had a solo show at the Musée des Arts Décoratifs. The designer collaborates with Ligne Roset, LucePlan, Wästberg, Moustache, Alessi, Almedahls, Hay, Svenkst Tenn and Cassina.

PATRICIA URQUIOLA

Architetto e designer spagnola, ma italiana di adozione, fa parte del team Mutina dal 2008. Ha disegnato numerose collezioni, tra cui Déchirer, Bas-Relief, Azulej, Tierras, Déchirer XL, Celosia ed El Lobo. Patricia Urquiola è nata a Oviedo, in Spagna, ma vive e lavora a Milano da più di vent'anni. Dopo essersi laureata nel 1989, è stata assistant lecturer per Achille Castiglioni, ha collaborato con Vico Magistretti ed è stata responsabile Design per Lissoni Associati. Nel 2001, ha aperto il suo studio lavorando nei settori del product design, interni e architettura. Ha realizzato progetti retail e allestimenti per Gianvito Rossi, BMW, Flos, Missoni, Moroso, Officine Panerai, H&M, Santoni, Pitti Uomo Firenze e ha vinto diversi premi internazionali tra cui: la “Medalla de Oro al Mérito en las Bellas Artes” del Governo Spagnolo, l'Ordine di Isabella la Cattolica, consegnato da Sua Maestà il Re di Spagna Juan Carlos I, “Designer del decennio” e “Designer dell'anno”.

Patricia Urquiola, Spanish architect and designer, adopted Italian, joined the Mutina team in 2008. She designed numerous collections, including Déchirer, Bas-Relief, Azulej, Tierras, Déchirer XL, Celosia and El Lobo. Patricia Urquiola was born in Oviedo, Spain, but has lived and worked in Milan for over twenty years. After graduating in 1989, she has been assistant lecturer to Achille Castiglioni, she collaborated with Vico Magistretti and was Head of Design at Lissoni Associati. She opened her own studio in 2001, working in product design, interior design and architecture. She worked on retail and fitting projects for Gianvito Rossi, BMW, Flos, Missoni, Moroso, Officine Panerai, H&M, Santoni, Pitti Uomo Firenze and won several international prizes, including: Medalla de Oro al Mérito en las Bellas Artes and the Order of Isabella the Catholic, awarded to her by King Juan Carlos I of Spain, “Designer of the Decade” and “Designer of the Year”.

VINCENT VAN DUYSSEN

Architetto e designer di origine belga, Vincent Van Duysen è entrato a far parte del team Mutina nel 2022. Ha realizzato le collezioni Kosei, Renga e Yama. Vincent Van Duysen nasce nel 1962 a Lokeren, in Belgio, e si laurea in architettura presso l'Istituto Sint-Lucas di Gent. Nel 1989 fonda lo studio Vincent Van Duysen Architects, che si occupa di product design per numerose aziende internazionali, progetti commerciali e architettonici, con focus su residenze di fascia alta in Belgio o sparse per Europa, Medio Oriente, Asia e Stati Uniti. Funzionalità, durata e comfort sono i componenti principali del lavoro, un linguaggio architettonico che trasmette l'estetica senza timidezza, ma incline a rifuggire la moda e le tendenze. Durante la sua carriera, Van Duysen ha ricevuto numerosi premi, tra cui: Flemish Culture Prize for Design, Belgian Designer of the

Year, Henry van de Velde Lifetime Achievement Award e un EDIDA come miglior designer di interni dell'anno.

Belgian architect and designer, Vincent Van Duysen joined the Mutina team in 2022. He designed the Kosei, Renga and Yama collections. Vincent Van Duysen was born in Lokeren, Belgium, in 1962. He earned a degree from the Sint-Lucas School of Architecture, Ghent, and he established Vincent Van Duysen Architects in 1989. The studio focuses on product design for numerous international brands, to commercial and large-scale architectural projects, with a focus on high-end residences both in Belgium or spread across Europe, the Middle East, Asia and the USA. Functionality, durability and comfort are the prime components of the work, an architectural language not shy to convey aesthetics, but prone to eschew fashion and trends. During his career, Van Duysen has received multiple awards among which the Flemish Culture Prize for Design, Belgian Designer of the Year and the Henry van de Velde Lifetime Achievement Award, and an EDIDA for Best Interior Designer of the Year.

TOKUJIN YOSHIOKA

Tokujin Yoshioka, artista e designer giapponese, è entrato a far parte del team Mutina nel 2010. Ha disegnato le collezioni Phenomenon, Botanica e Phenomenon Plate. Tokujin Yoshioka si forma con Shiro Kuramata e Issey Miyake, per poi aprire il proprio studio nel 2000. Ha collaborato con aziende come Hermès, Toyota, BMW, Swarovski, Driade, Moroso e Kartell, tra gli altri. La cifra caratteristica del suo approccio creativo è costituita dalla poesia e dalla leggerezza onirica delle sue opere, che nascono da un'attenta e sofisticata ricerca su materiali semplici abbinata alla sperimentazione tecnologica. Alcuni dei suoi pezzi sono esposti al MoMA, al Musée National d'Art Moderne e al Victoria and Albert Museum. Ha vinto diversi premi, tra cui: Design Miami, Designer of the Year 2007, Wallpaper Design Awards 2008 e Elle Decoration International Design Award, Designer of the Year 2009. Grazie alla collezione Phenomenon, disegnata per Mutina, nel 2011 ha ricevuto il Wallpaper Design Award e l'Elle Decoration Design Award.

Japanese artist and designer Tokujin Yoshioka joined the Mutina team in 2010. He designed the Phenomenon, Botanica and Phenomenon Plate collections. Tokujin Yoshioka trained with Shiro Kuramata and Issey Miyake, and opened his studio in 2000. He collaborated with brands such as Hermès, Toyota, BMW, Swarovski, Driade, Moroso and Kartell, among others. The signature feature of his creative approach is the poetic and light, dreamlike quality of his work, which stems from attentive and sophisticated selection of simple materials combined with technological experimentation. Some of his works are exhibited at MoMA, at Musée National d'Art Moderne and the Victoria and Albert Museum. His awards include Design Miami, Designer of the Year 2007, Wallpaper Design Awards 2008 and Elle Decoration International Design Award, Designer of the Year 2009. In 2011 he received the Wallpaper Design Award and the Elle Decoration Design Award for his Phenomenon collection designed for Mutina.

Mutina for Art

Mutina for Art è il percorso che l'azienda dedica all'arte contemporanea. Mutina for Art nasce nel MUT, lo spazio espositivo dedicato all'interno della sede di Fiorano Modenese, che dal 2021 si sviluppa anche nello spazio di Casa Mutina Milano. Oltre a un regolare programma di mostre personali e collettive, il progetto comprende il premio This Is Not a Prize, assegnato annualmente per sostenere un artista internazionale, e Dialogue, una serie di iniziative di collaborazione con artisti, gallerie e istituzioni nel mondo.

Mutina for Art is a project dedicated to contemporary art that originates at MUT, an exhibition space within Mutina Headquarters in Fiorano Modenese, which, from 2021, has also been developing in the space of Casa Mutina Milano. Besides a regular programme of solo and group shows, the Mutina for Art initiative also comprises the award This Is Not a Prize, given annually in the support of an international artist, and Dialogue, a series of collaborative projects with artists, galleries and institutions worldwide.

MUT Exhibitions

Programma di mostre di arte contemporanea nato nel MUT, lo spazio espositivo dedicato all'interno della sede Mutina di Fiorano Modenese, e che dal 2021 si sviluppa anche nello spazio di Casa Mutina Milano.

Programme of contemporary art exhibitions which originated at MUT, a dedicated exhibition space within Mutina Headquarters in Fiorano Modenese, and that from 2021 it develops also in the space of Casa Mutina Milano.

Nathalie Du Pasquier, *BRIC*
Opposite page – Luigi Ghirri, *Between the lines*





This Is Not a Prize

Un format innovativo mirato a supportare e promuovere l'opera di artisti emergenti. Il riconoscimento offerto da Mutina segna l'inizio di un rapporto tra l'azienda e l'artista selezionato, che può svilupparsi in base ai bisogni specifici della sua pratica.

An innovative format aimed at supporting and promoting the work of emerging artists. The recognition offered by Mutina marks the beginning of the company's relationship with the chosen artist, which can develop according to the specific needs of his/her practice.



Nathalie Du Pasquier,
Mind the Gap

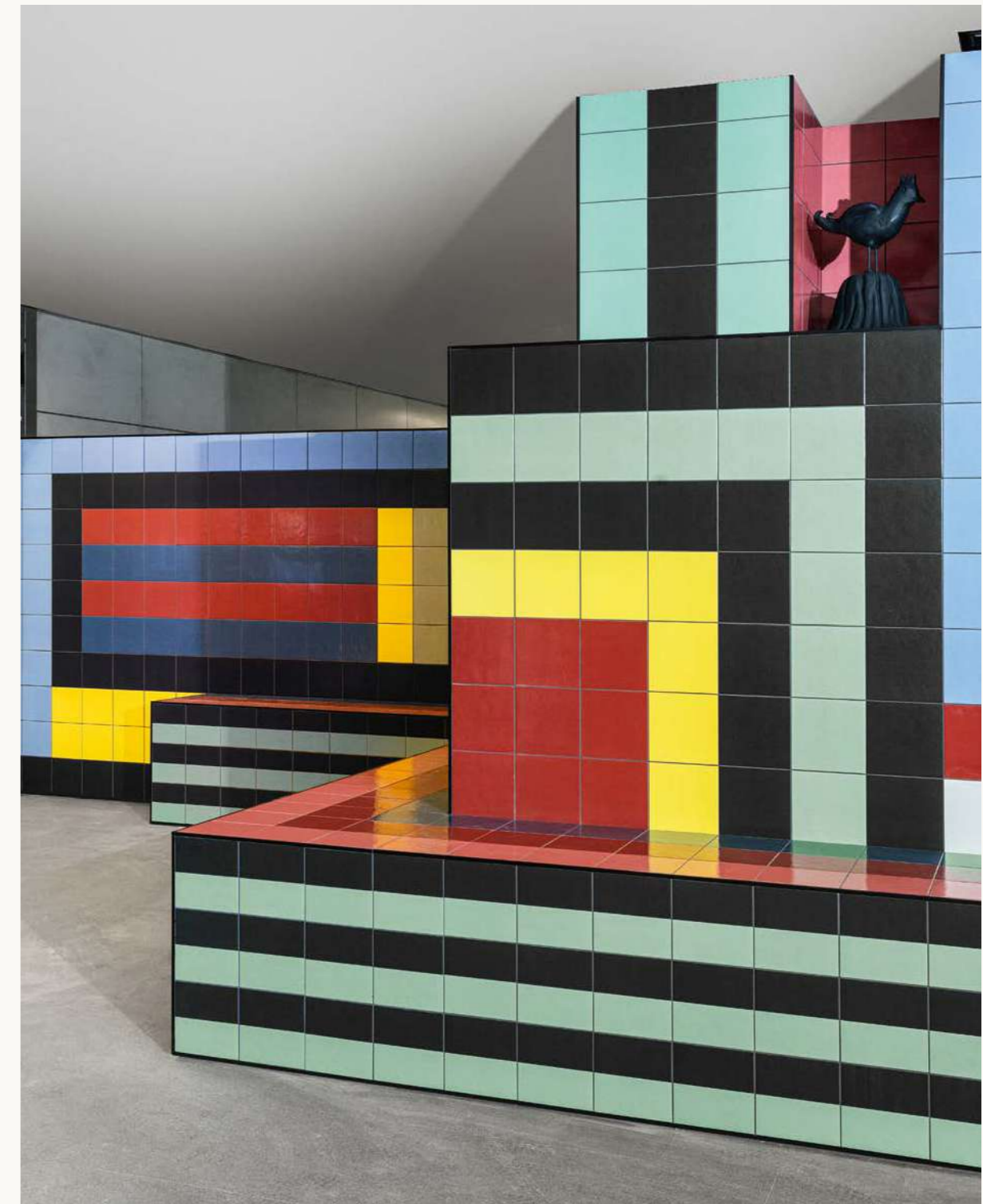

Dialogue

Iniziative artistiche itineranti, che prendono forma attraverso progetti con artisti, musei o istituzioni, ma anche opere site-specific pensate per i futuri flagship-store Mutina, con l'obiettivo di produrre opere d'arte che fanno uso sperimentale del materiale ceramico.

Itinerant artistic initiatives that take shape through projects with artists, museums or institutions, as well as through site-specific works conceived for the Mutina flagship-stores, with the aim of producing artworks which make experimental use of ceramics.

Mutina Venues

Le anime che compongono l'universo Mutina – Mutina Collections, Mutina Interiors e Mutina for Art – vengono concretizzate all'interno di Spazio Mutina, la sede centrale del brand con base a Fiorano Modenese, di Casa Mutina Milano e Casa Mutina Modena.

Cuori pulsanti dell'azienda, questi luoghi sono pensati per permettere a collaboratori, professionisti e clienti di scoprire la gamma di prodotti Mutina e approfondirne l'approccio creativo attraverso allestimenti, mostre, eventi esclusivi e incontri con i designer del team Mutina. Sensibilità per la forma, desiderio di innovare e volontà di incorporare gli stimoli visivi più eterogenei del mondo attuale, aspetti che fanno parte della visione del brand fin dalla sua nascita, prendono qui forme e interpretazioni sempre nuove, che riflettono la natura di un'azienda in continua evoluzione.

The souls that compose Mutina universe – Mutina Collections, Mutina Interiors and Mutina for Art – come to life within Spazio Mutina, the Headquarters based in Fiorano Modenese, Casa Mutina Milano and Casa Mutina Modena.

Beating hearts of the company, these venues are conceived to allow partners, professionals and clients to discover the product range of the brand as well as deepening into its creative approach, through installations, exhibitions, exclusive events and meetings with the designers of Mutina team. Sensitivity for shape, a desire to innovate and to take on board an incredible variety of visual stimuli from today's world, aspects that belong to the brand vision from the very beginning, take always new shapes and interpretations, reflecting the nature of a constantly evolving company.

Spazio Mutina

Spazio Mutina è stato progettato da Studio Urquiola, in collaborazione con l'Area Progetti dell'azienda, per creare un'oasi dove fare esperienza dell'universo Mutina – Mutina Collections, Mutina Interiors, Mutina Editions e Mutina for Art – attraverso la fluidità degli spazi e la costante interazione tra natura e luce. La nuova sede è stata pensata come un percorso fluido e museale, capace di raccontare ciascuna esperienza e la storia di ogni prodotto. In questo modo, i visitatori vengono accompagnati nella scoperta delle diverse anime del brand: il design, le superfici, la contaminazione dell'arte e il mondo dell'architettura d'interni.

Spazio Mutina was designed by Studio Urquiola, in collaboration with the Project Division of the company, as an oasis to experience the Mutina universe – Mutina Collections, Mutina Interiors, Mutina Editions and Mutina for Art – through the fluidity of spaces and the constant interaction between nature and light. The new venue has been conceived as a fluid museum-like space that tells the story of each experience and product. In this way, the visitors are guided to the discovery of the different souls of the brand: design, surfaces, the contamination of art and the world of interior architecture.





Casa Mutina Milano

Situata nel cuore del quartiere di Brera, uno dei distretti storici più caratteristici della città nonché polo privilegiato per l'arte e per il design, Casa Mutina Milano si propone come luogo in cui il prodotto diventa protagonista all'interno di una vera e propria abitazione. Lo spazio prende vita attraverso un programma di mostre, eventi speciali e talk, invitando architetti e professionisti del settore a scoprire le collezioni e la realtà dell'azienda in modo nuovo e continuativo.

Located in the heart of Brera district, one of the most distinctive historical neighborhoods of the city, Casa Mutina Milano is a place where the product becomes the protagonist inside a real home. The space comes to life through a programme of exhibitions, special events and talks, inviting architects and specialists in the field to discover the collections and the essence of the company on a new, ongoing basis.



Nathalie Du Pasquier, *Elementi per Paesaggi*
at Casa Mutina Milano

Casa Mutina Modena

Casa Mutina Modena è la prima espressione tangibile del progetto Interiors: lo spazio prende vita attraverso un mix di colori, texture e materiali, mostrando come utilizzare in modo trasversale tutte le collezioni Mutina. Inoltre, costituisce una residenza pensata per accogliere gli ospiti e i collaboratori dell'azienda che vengono da lontano. Il progetto di restyling è stato realizzato da OEO Studio di Copenhagen, in collaborazione con l'Area Progetti di Mutina, che si è occupato della nuova disposizione degli spazi e dei dettagli strutturali, adattandoli a una visione più contemporanea, pur preservando l'autenticità e l'architettura dell'edificio originale.

Casa Mutina Modena is the first tangible expression of the project Interiors: the space comes to life thanks to a combination of colours, textures and materials, showing how to use all Mutina collections in a transversal way. Furthermore, it is a residence for guests and Mutina staff. The interiors have been designed by Copenhagen-based practice OEO Studio, in collaboration with Mutina's Project Division, who were responsible for the new spatial planning and architectural detailing that provided for a more contemporary context, while at the same time preserving the authenticity and architecture of the building.

Casa Mutina Modena, project by OEO Studio
in collaboration with Mutina's Project Division



TILES

Tiles	Azulej	Patricia Urquiola	64
	Bas-Relief	Patricia Urquiola	76
	Botanica	Tokujin Yoshioka	84
	Chymia	Laboratorio Avallone	92
	Déchirer	Patricia Urquiola	98
	Déchirer (La Suite)	Patricia Urquiola	98
	Déchirer ^{xl}	Patricia Urquiola	110
	Diarama	Hella Jongerius	114
	Din	Konstantin Grcic	124
	Flow	Mutina Team	136
	Folded	Raw Edges	140
	Folded ^{xl}	Raw Edges	146
	Kosei	Vincent Van Duysen	152
	Lane	Edward Barber & Jay Osgerby	166
	Mattonelle Margherita	Nathalie Du Pasquier	174
	Mews	Edward Barber & Jay Osgerby	186
	Phenomenon	Tokujin Yoshioka	196
	Pico	Ronan & Erwan Bouroullec	208
	Primavera	Edward Barber & Jay Osgerby	220
	Punto	Ronan & Erwan Bouroullec	232
	Puzzle	Edward Barber & Jay Osgerby	242
	Rombini	Ronan & Erwan Bouroullec	254
	Tape	Raw Edges	266
	Teknotessere	Mutina Team	276
	Tex	Raw Edges	280
	Tierras	Patricia Urquiola	290

Azulej Patricia Urquiola

Azulej è volta a rivalorizzare la memoria delle antiche maioliche artigianali e del cemento idraulico, sperimentando una tecnica di stampa innovativa orientata verso un prodotto di larga diffusione. Questa tradizione – rivisitata in chiave contemporanea – viene realizzata serialmente in formato 20x20 cm. La composizione riprende le caratteristiche della tecnica patchwork: un mix and match innovativo, volutamente casuale, che abbina disegni astratti e colori non saturi, neutri, appena consumati. In questo modo i pattern di Azulej combinano linguaggi volutamente diversi: memoria, geometrie, pixel, sviluppati sia in senso longitudinale che diagonale. Un risultato unico e sorprendente, che regala libertà compositiva e unicità di disegno, mantenendo intatte le caratteristiche del 'fatto a mano', con le prestazioni di un materiale ad alta tecnologia adatto sia a pavimenti che a rivestimenti.

Azulej is aimed at re-evaluating the memory of ancient hand-crafted majolica and hydraulic cement, experimenting with an innovative printing technique aimed at mass distribution. This tradition – revisited in a contemporary way – is serially produced in a 20x20 cm size. The composition echoes the characteristics of the patchwork technique: an innovative, intentionally random mix and match, which combines abstract designs and unsaturated, neutral, barely consumed colours. That's how Azulej's patterns combine intentionally different languages: memory, geometries, pixels, developed both longitudinally and diagonally. A unique and surprising result, which gives compositional freedom and unique design, keeping the characteristics of the "hand-made", with the performance of a high-tech material suitable for both floors and walls.





Opposite page – Azulej Grigio
Azulej Grigio: Flores, Estrela





“Con la collezione Azulej volevamo dare nuovo valore alla memoria del cemento idraulico. Un processo sviluppatosi in modo esponenziale, dove abbiamo voluto abbozzare soltanto le prime combinazioni di una lunga serie. E ora, it’s up to you!”

“With the collection Azulej, we wanted to evaluate the memory of the hydraulic cement. The process has exponentially developed, and we have managed only to sketch some possible combinations...Now, it’s up to you!”

Patricia Urquiola

Previous page – Azulej Nero
Opposite page – Azulej Nero: Gira



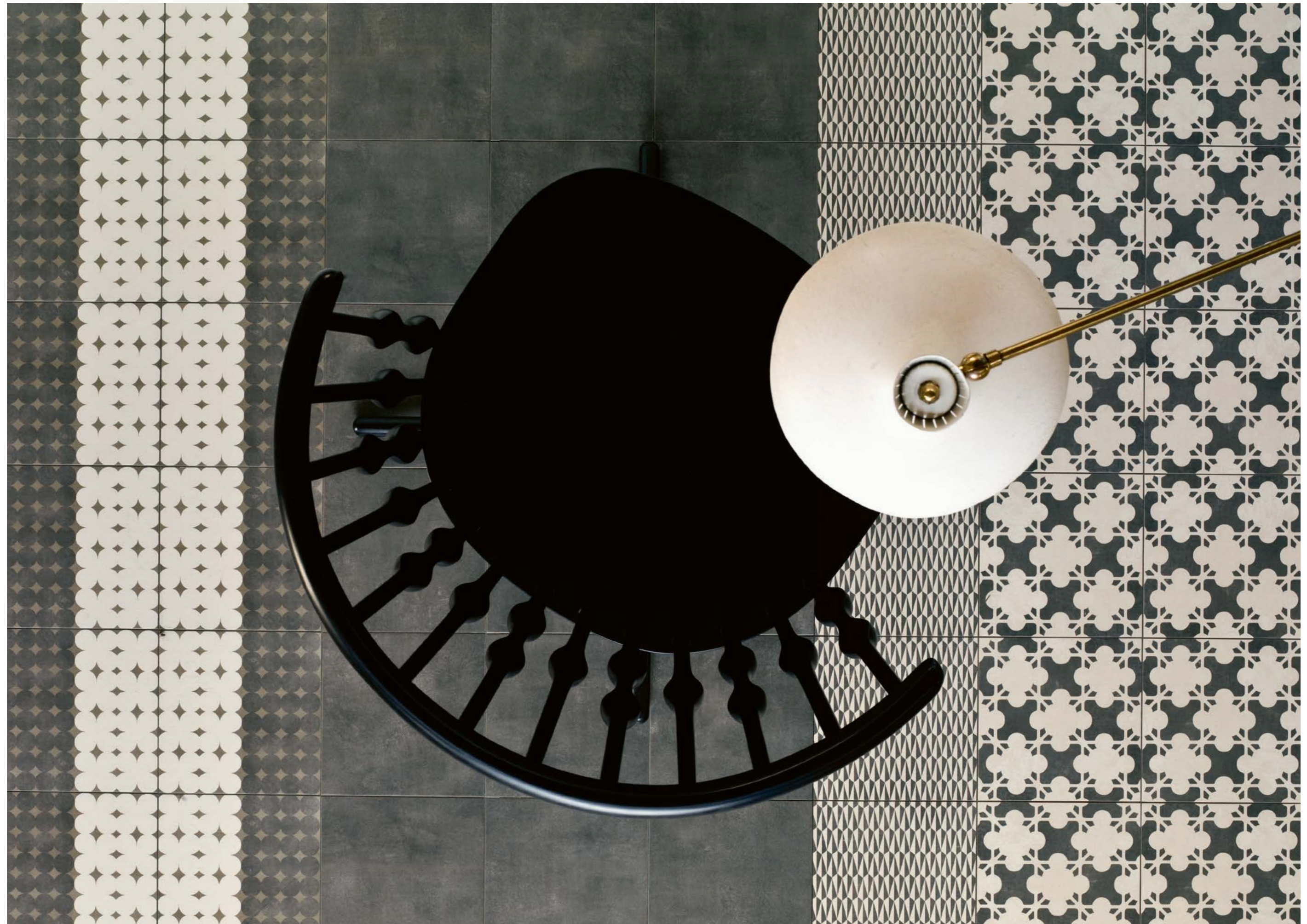

Opposite page – Azulej Nero: Trama, Estrela
Azulej Bianco: Cubo, Trevo, Estrela, Flores, Renda

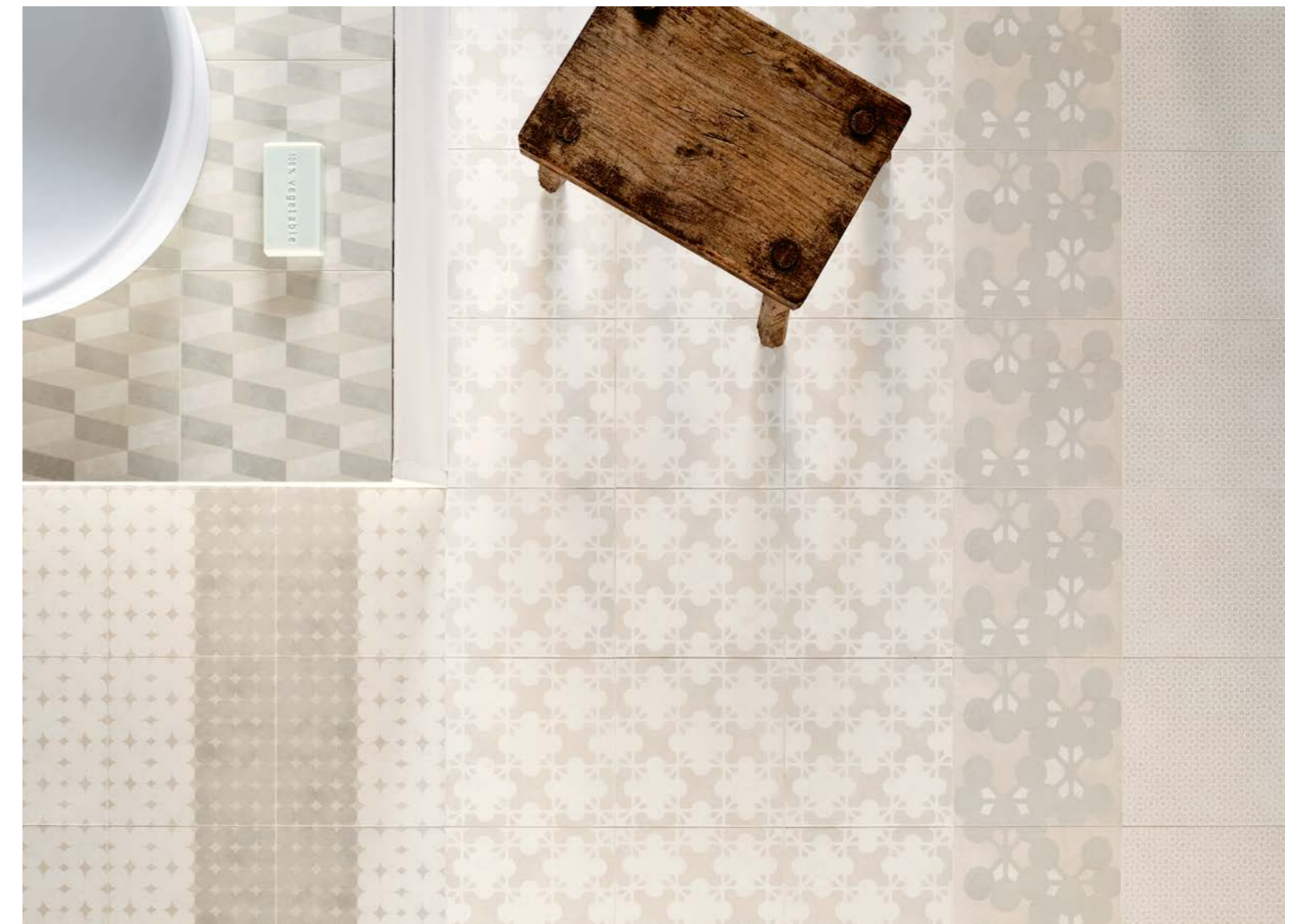

Bas-Relief

Patricia Urquiola

Bas-Relief è una collezione di produzione artigianale che vede protagonista l'antica arte del bassorilievo, qui riproposta in quattro diversi pattern decorativi – tre da rivestimento in formato 18x54 cm e uno da pavimento in formato 26,5x18 cm. La texture sofisticata e rigorosa di Code dà vita a un movimento che si ripete come un codice sulla superficie; Patchwork consiste invece in un mix and match di motivi che creano un disegno in continua evoluzione; con Garland, l'elemento floreale viene rivisitato in chiave contemporanea e digitale; Cloud, infine, è aereo e leggero come una nuvola, capace di creare un disegno astratto e continuo. Bas-Relief è declinata in toni neutri e naturali quali bianco, cipria e nero, utilizzati in chiave innovativa. La finitura degli elementi presenta diverse profondità che restituiscono un effetto chiaroscuro più o meno pronunciato a seconda della luce.

Bas-Relief is a handmade collection where the ancient art of bas-relief becomes the protagonist, by being proposed in four different decorative patterns: three patterns just for wall covering in a 18x54 cm size and one for floor covering in a 26,5x18 cm size. Code is characterized by an austere and refined texture, expressed through a movement that repeats itself on the surface as a code; Patchwork consists of a mix and match of patterns that creates a constantly evolving design; in Garland, the flower element is revised with a contemporary and digital attitude; Cloud, the last one, is airy and light as a cloud, and it creates an abstract and constant design. Bas-Relief is declined in natural and neutral tones such as white, powder and black, applied in an innovative way. The elements of the collection are characterized by different depths that create a chiaroscuro effect whose intensity depends on light.

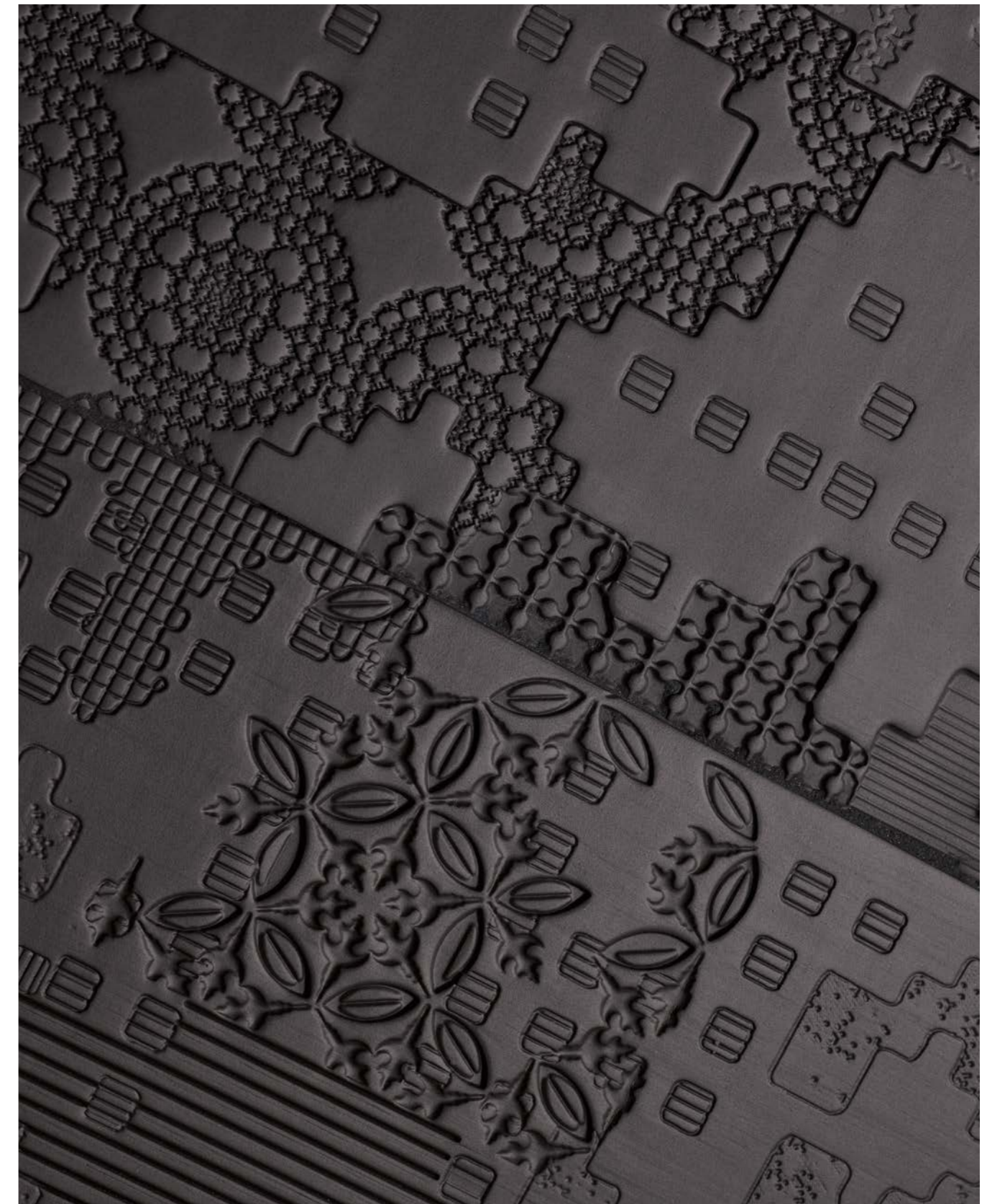



Bas-Relief Code Bianco
Opposite page – Bas-Relief Garland Bianco







Previous page – Bas-Relief Code Cipria
Bas-Relief Patchwork Nero



Botanica

Tokujin Yoshioka

Con Botanica, Tokujin Yoshioka continua a esprimere la sua profonda fascinazione per il mondo naturale, i suoi fenomeni e la poetica delle forme che ne fanno parte, progettando il primo mosaico Mutina pensato appositamente per il pavimento. La collezione viene realizzata in grès porcellanato smaltato e non rettificato, utilizzando un innovativo sistema digitale di applicazione a secco degli smalti. Botanica propone due elementi ispirati alla natura, tanto nel nome quanto nelle linee: Seed, di dimensioni 14x15 cm, e Flower, di dimensioni 15x17 cm, entrambi con uno spessore di 9 mm. I moduli sono venduti esclusivamente su rete – Seed in un formato di 23,7x40,5 cm e Flower in un formato di 23,5x41,1 cm – e sono disponibili nelle colorazioni White e Grey, a loro volta declinate in una finitura super glossy e una matt cerata estremamente piacevole al tatto, e sono adatti sia alla posa a pavimento che a rivestimento. Questo consente di dare continuità alle superfici, dove il mosaico risulterà più o meno enfatizzato a seconda del colore dello stucco.

With Botanica, Tokujin Yoshioka expresses once again his deep fascination for the natural world, its different characteristics and the poetry of its forms, designing the first Mutina mosaic specially developed for floors. The collection is produced in non-rectified glazed porcelain stoneware, with an innovative digital system for the dry application of glazes. Botanica features two elements inspired by nature, the names and the lines: Seed, in 14x15 cm format, and Flower, in 15x17 cm format, both with a thickness of 9 mm. The modules are sold exclusively on net – Seed in a 23,7x40,5 cm format and Flower in a 23,5x41,1 cm format – and are available in White and Grey colours, offered in a super glossy finish and a matt wax-coated one which is extremely pleasant to the touch, and are suitable for floors and walls. This makes it possible to give the surfaces continuity, in which the mosaic becomes more or less emphasised depending on the colour of the grout.



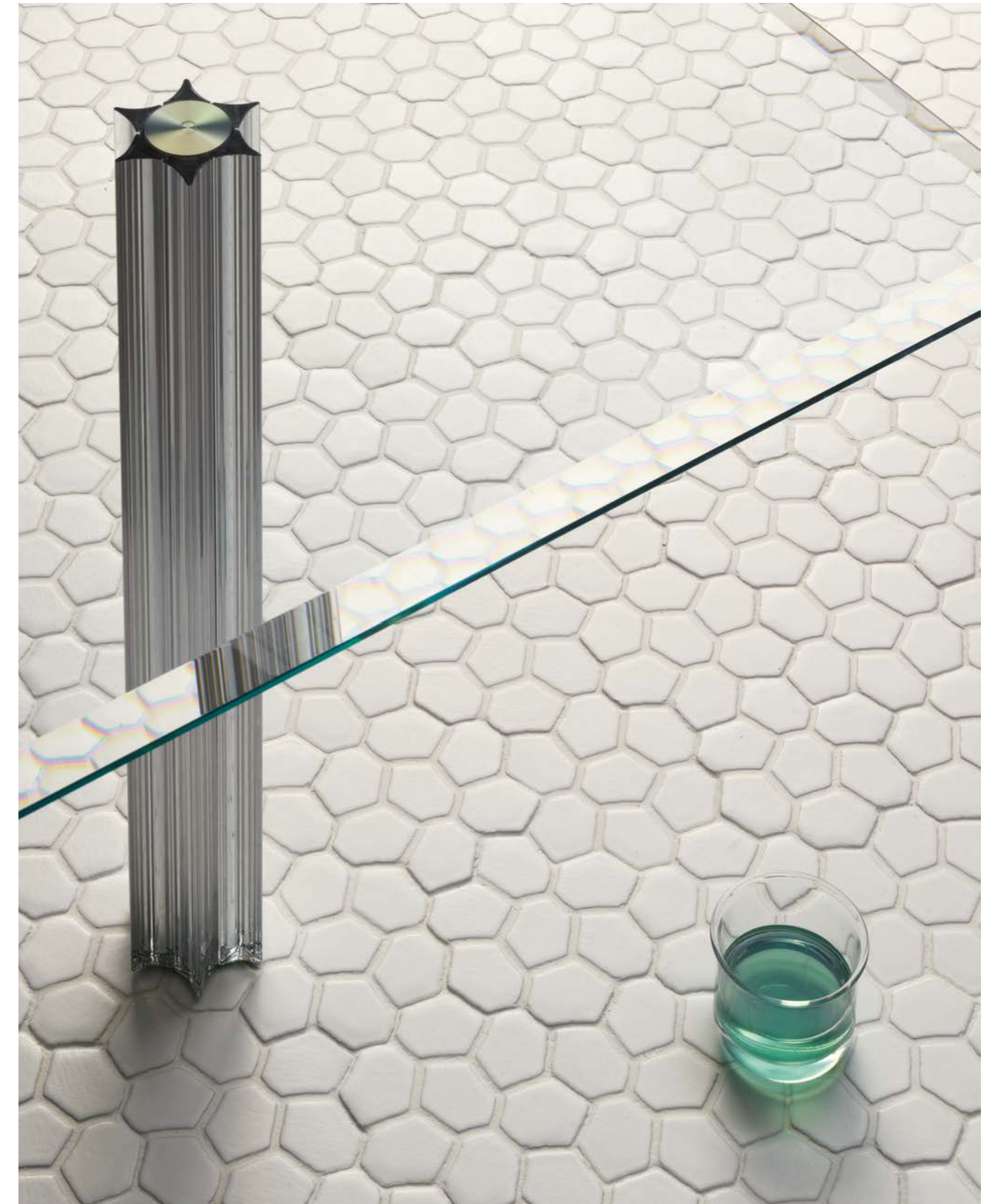



“Per la collezione Botanica, ho creato un progetto che implementa la bellezza della natura nelle forme, come a dipingere un paesaggio. I sensi sono un elemento fondamentale del mio processo di progettazione. Non solo quelli materiali e visuali, come il tatto e la vista, ma anche quelli più “astratti” come l’olfatto. Vivo nella costante ricerca di qualcosa che sia definito e percepito da tutti e cinque i sensi”.

“For the Botanica collection, I have created a design that expresses the beauty of nature in different forms, as if I were painting a landscape. Senses are a fundamental element of my creative process. Not only material and visual ones, such as touch and sight, but also more “abstract” ones, such as the sense of smell. I am constantly looking for something that is defined and perceived by all the five senses.”

Tokujin Yoshioka



Chymia

Laboratorio Avallone

Chymia evoca il processo alchemico di trasformazione della materia. La collezione si muove tra grafica e gestualità, tra i due estremi del bianco e del nero, in cui si combinano trame segniche e materiche che tracciano luce e ombra in superficie. Le due dimensioni cromatiche non sono però mai disgiunte tra loro, ma coesistono nella loro dualità.

Chymia è realizzata in grès porcellanato smaltato ed è composta da 22 elementi delle dimensioni di 30x30 cm con spessore di 10 mm, ottenuti attraverso la combinazione delle strutture base con 11 grafiche, che possono essere installati in maniera assolutamente randomica. Ognuno di essi è rettificato e proposto nelle versioni Black e White. Dall'ampio range a disposizione sono stati poi selezionati quattro mix composti da 6 diversi articoli, dove il filo conduttore è il colore.

Chymia evokes the alchemical process of transformation of raw material. The collection consists of a series that fluctuates between the discipline of graphic design and the expressive gestures of mark-making, as well as between the two extremes of black and white, in which symbols and textures are combined to create patterns of light and shadow on the surface. Black and white are never separate but co-exist. Chymia is produced in glazed porcelain stoneware and is composed by 22 elements in the single size of 30x30 cm and thickness of 10 mm, obtained by combining the principle structures with 11 textures, that can be placed randomly. They are rectified and available in both Black and White versions. Starting from the wide range, four mixes of 6 different articles (linked by the colour) have been realised.

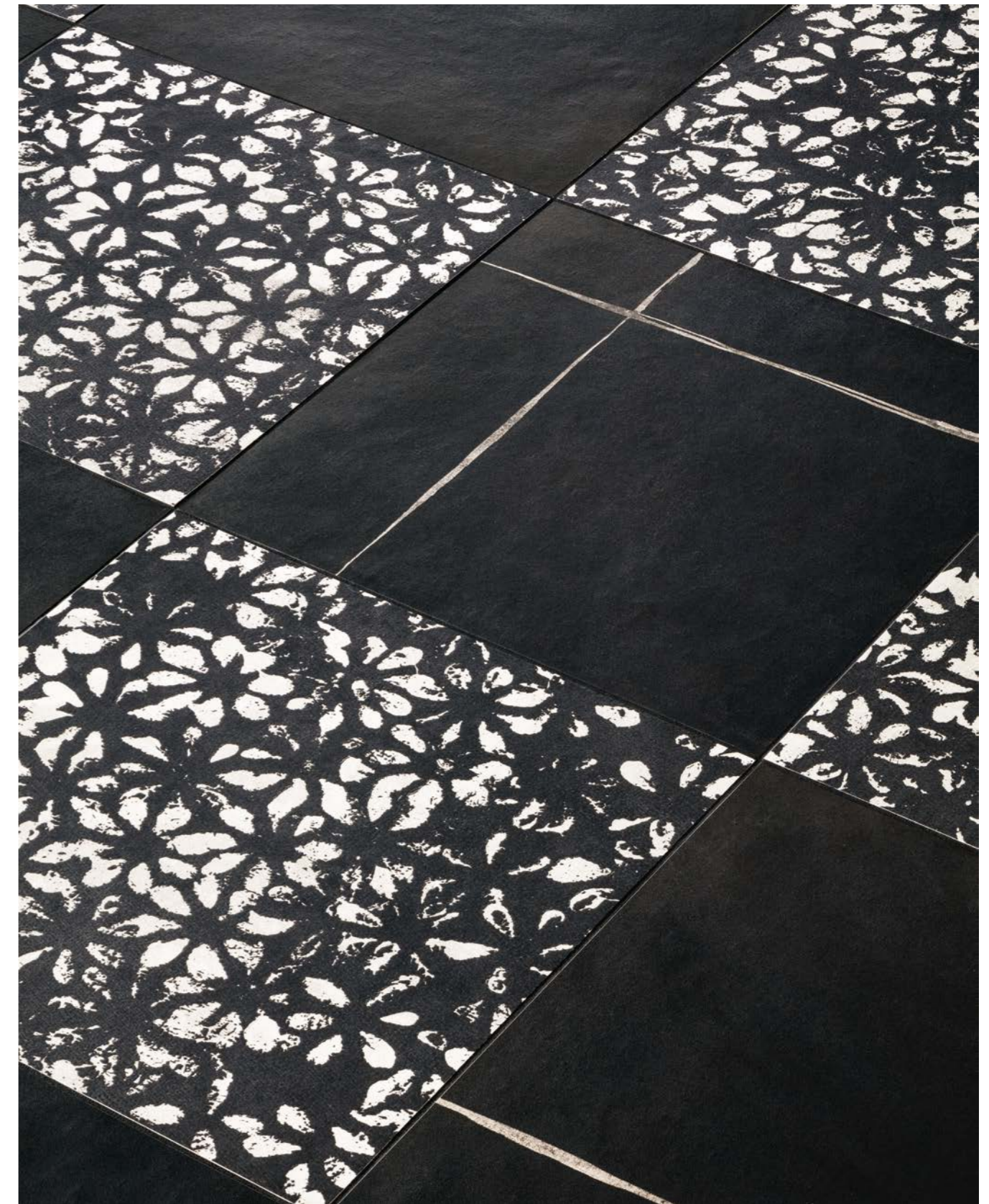

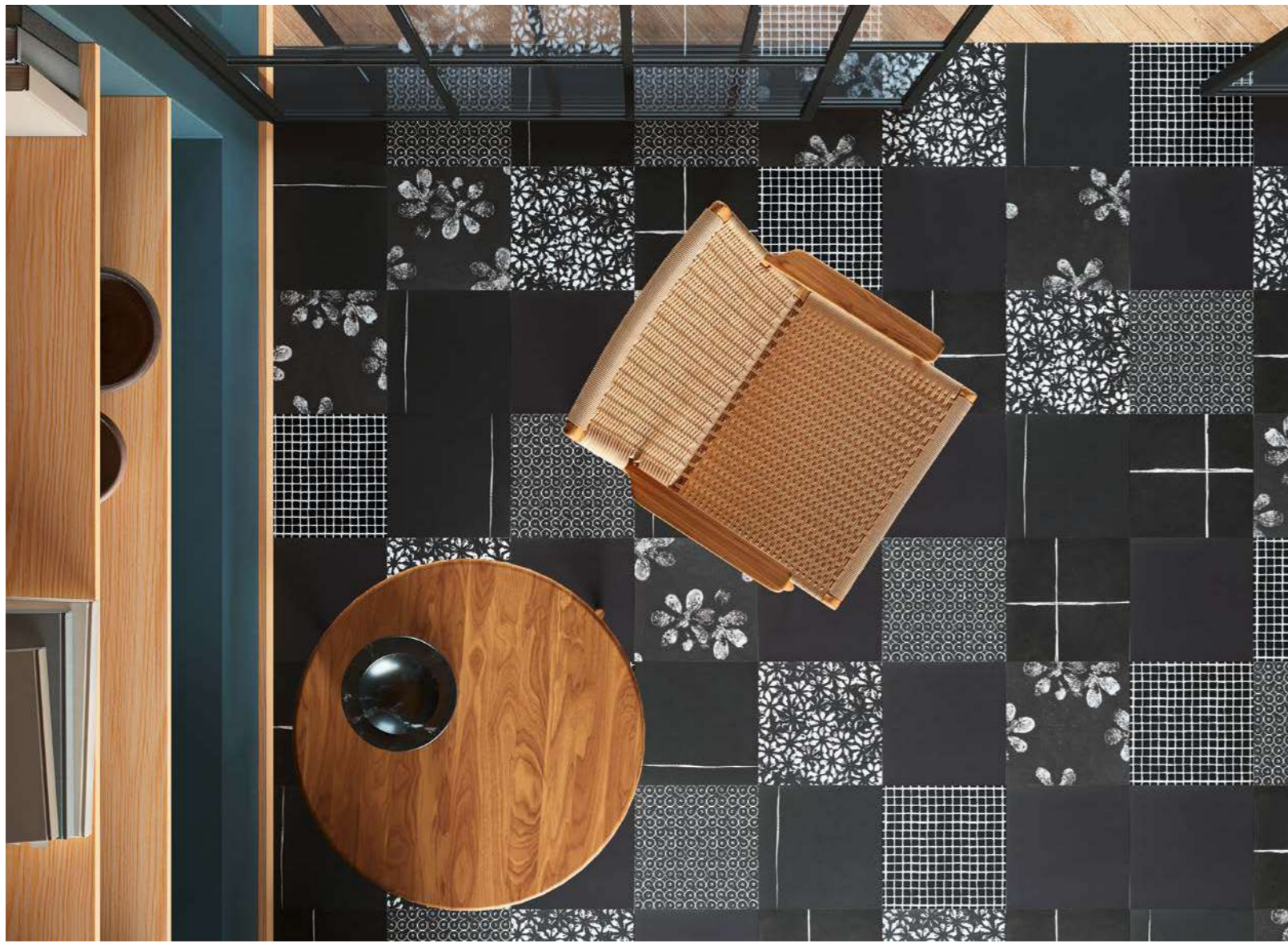

Chymia Mix 2 Black
Opposite page – Wall: Chymia Mix 2 White.
Accents Paint: Terra Matt (cube).

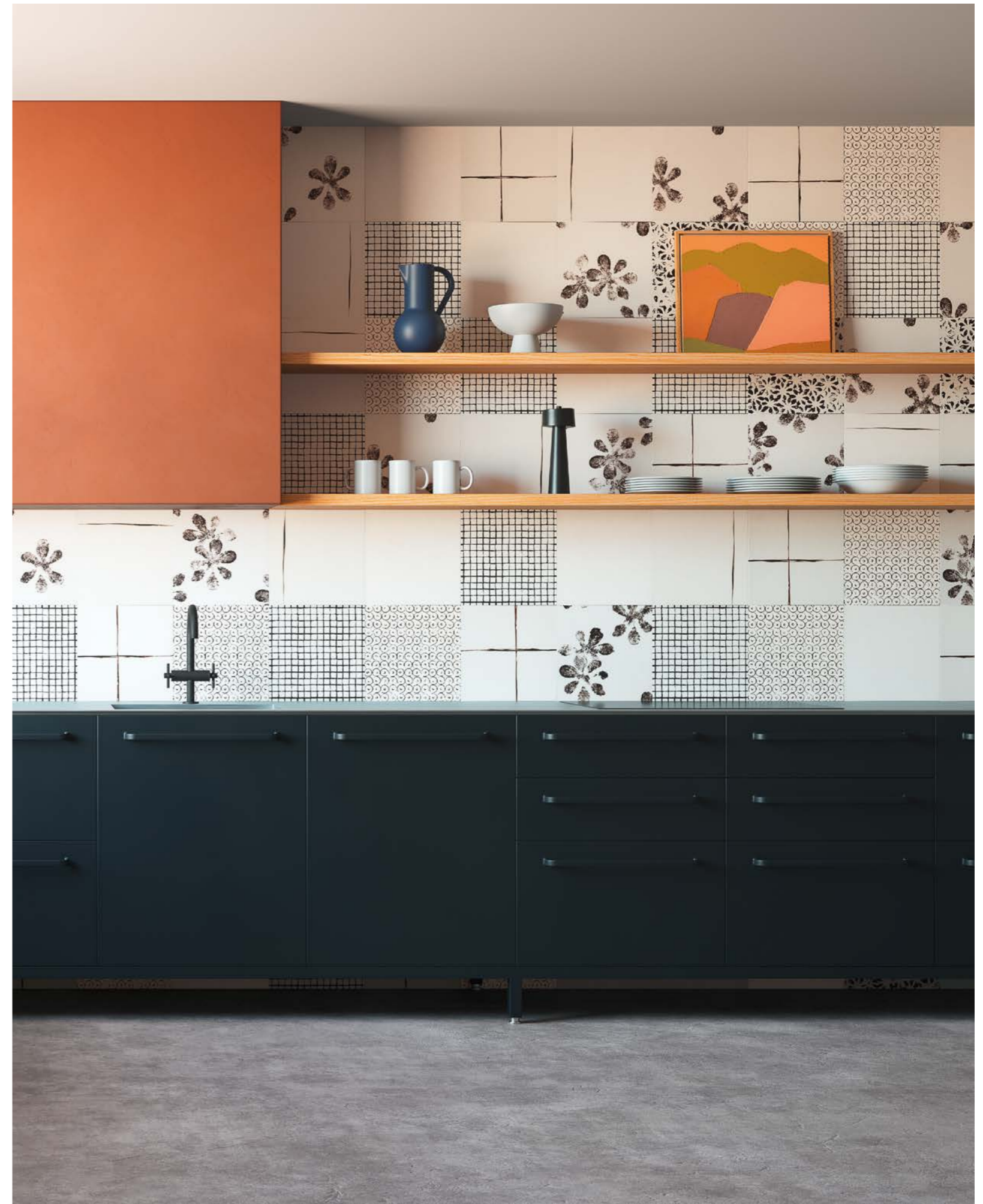



Floor: Chymia Tassello Black. Wall: Chymia Flat White, Ophelia White + Accents Paint: Slate Matt. Ceiling: Accents Paint: Pearl Matt.

Chymia Drops Black, Drops White



Déchirer

Patricia Urquiola

Déchirer ha segnato una rivoluzione nel campo dei rivestimenti ceramici d'autore. L'uso della tecnologia Continua ha infatti permesso di realizzare lastre di grande formato in grès porcellanato non smaltato a impasto omogeneo – perfettamente monocalibro e modulari – adatte sia per la posa a pavimento che a rivestimento. I bassorilievi appena percettibili, che percorrono elegantemente la superficie, non sono mere decorazioni, ma rappresentano ciò che rimane di memorie strappate.

La collezione abbina superfici, texture e materie differenti, oltre a fare ricerca sui materiali, sperimentare nuove tecnologie e interpretare forme e colori. A questo si aggiunge l'importanza della sostenibilità: il rispetto della natura è una prerogativa nella realizzazione di Déchirer, che presta attenzione all'ambiente producendo un moderno e raffinato design eco-friendly.

Déchirer was a breakthrough in the world of designer tiles. The use of Continua technology allowed to realise large slabs in unglazed porcelain stoneware, modular and single work-size, that can be used both on floors and walls. The bas-reliefs that elegantly cross the surface are barely visible; they are not mere decorations, but represent what remains of torn memories. The collection combines surfaces, textures and different materials, as well as researching on materials, experimenting with new technologies, re-interpreting shapes and colours. Furthermore, sustainability and respecting the environment is a prerogative of the collection, which creates a modern and refined design that is also eco-friendly.

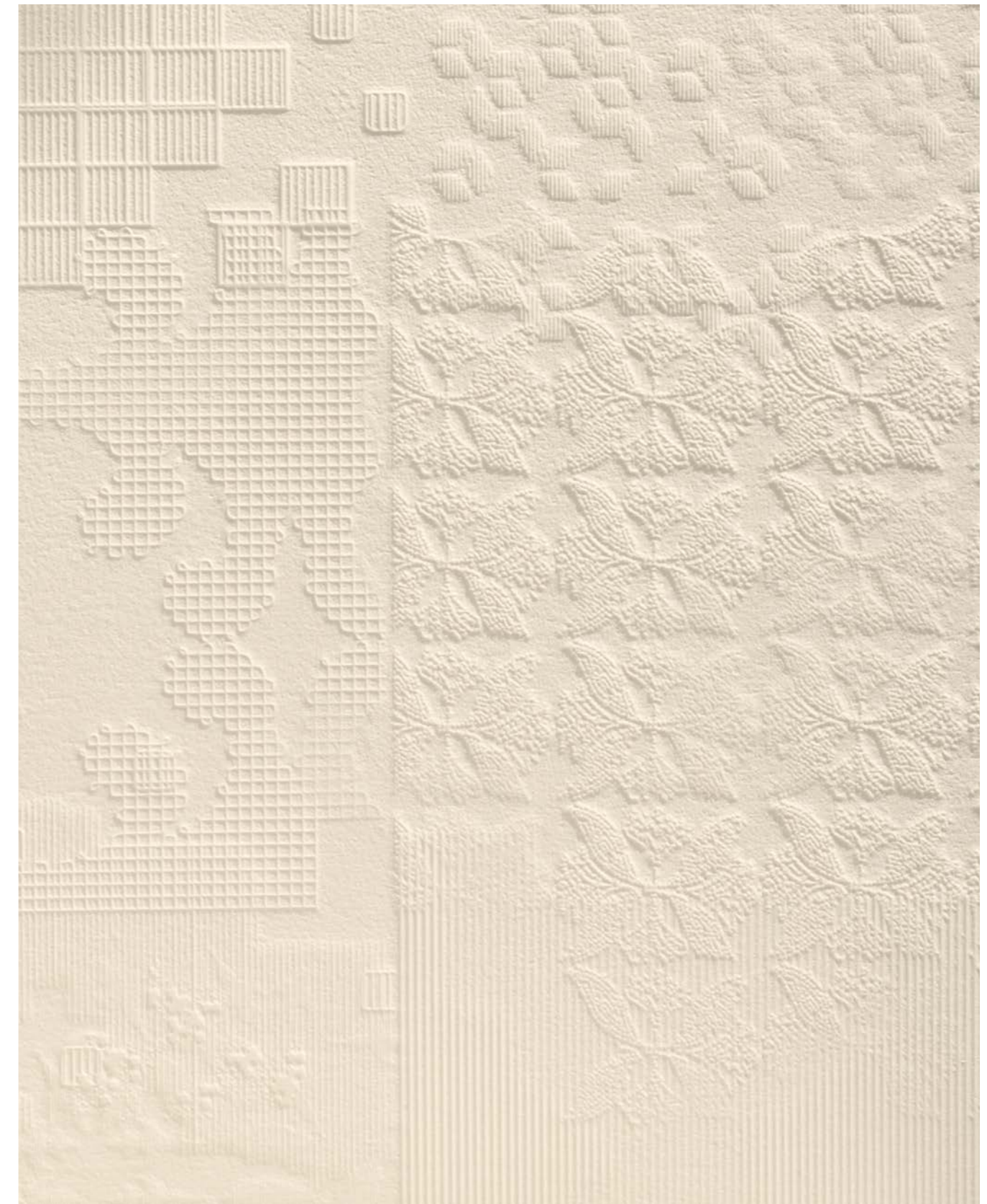



Déchirer Esagona Piombo, Déchirer mosaico random Piombo
Opposite page – Déchirer Decor Bianco
Next page – Déchirer Decor Nero

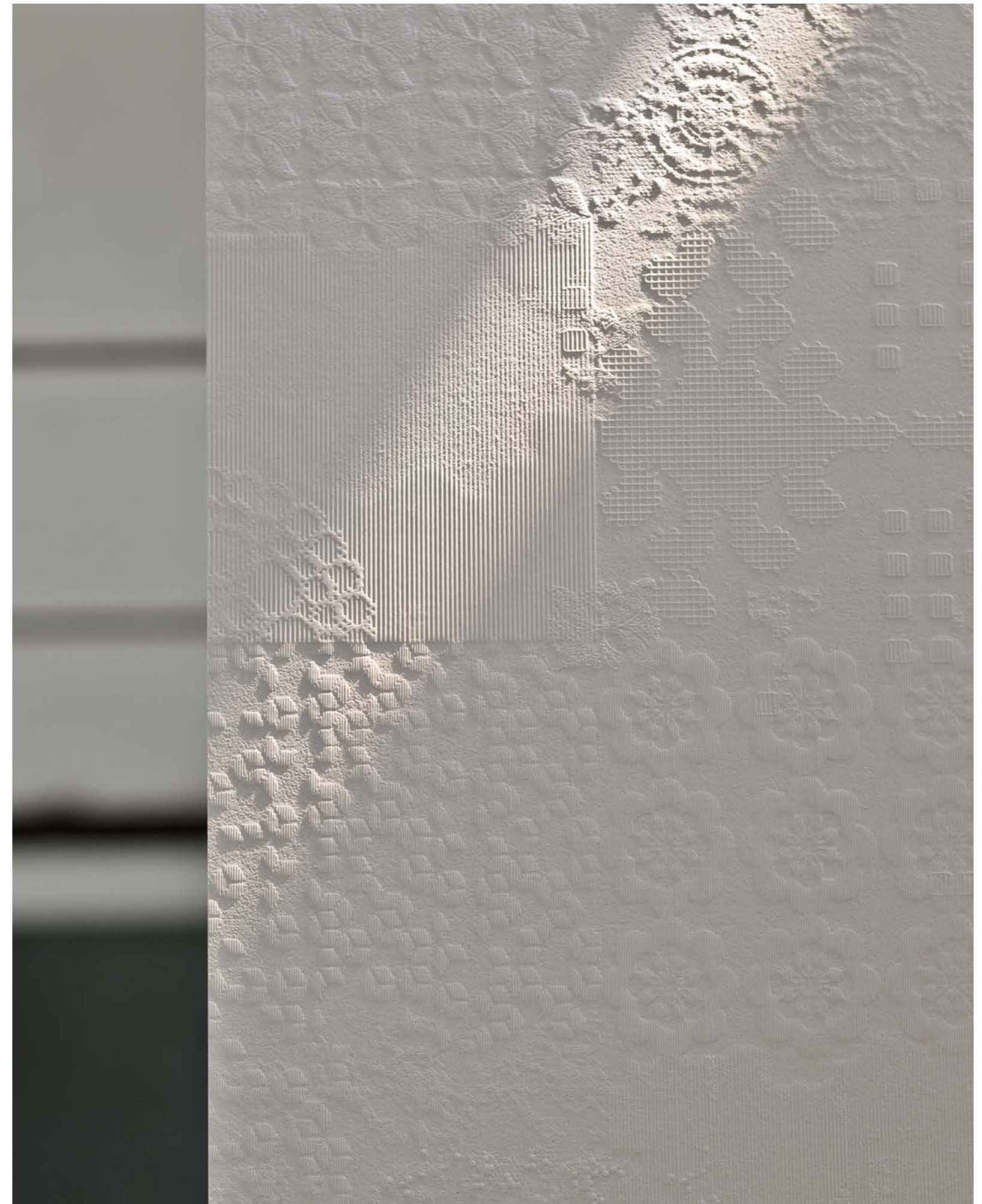





A conversation with
Patricia Urquiola

Déchirer è stata la tua prima collezione Mutina, un progetto rivoluzionario che ha richiesto circa un anno di lavoro. Come si è sviluppato?

Déchirer ha segnato l'inizio di una bellissima collaborazione, ma soprattutto di una profonda amicizia. Insieme a Massimo, volevamo creare una superficie che si ispirasse al passato, a impronte di stratificazioni precedenti, a delle sovrapposizioni di lievissime e irregolari percezioni di decoro. Una rimembranza di una carta da parati strappata, ecco perché il nome Déchirer. Il progetto si è sviluppato a partire dagli stampi di gesso, dando vita a una collezione che si offre alla sensibilità dei progettisti che, giocando con i suoi colori neutri, i decori e la luce, creano una visione personale.

Déchirer ha segnato un punto di svolta nel mondo delle superfici d'autore, aprendo la strada a ricerca e sperimentazione. Cos'è che la rende ancora oggi un progetto riconoscibile e senza tempo?

Déchirer è una collezione rivoluzionaria, una superficie impregnata di memoria, come un fossile... Pur essendo molto decorativa, segue una logica randomica. È un progetto elegante, ma non ridondante, che va al di là del momento e che offre diverse soluzioni, grazie alla possibilità di alternare elementi lisci e decorati. In questo modo, si crea una continua variazione di percezione della superficie, che cambia in base al mutare della luce nelle diverse ore del giorno e delle stagioni.

È stato proprio con questa collezione e con Mutina che hai iniziato a lavorare sulla ceramica. Come descriveresti oggi il tuo rapporto con questo materiale?

Lavorare con la ceramica per me è una maratona, con in mezzo delle gare da 100 metri, salto in alto e salto in lungo. Comporta tanta pazienza, tanta immaginazione, critica e autocritica. La ceramica è un materiale versatile, capace di adattarsi ed estremamente resistente. È un materiale con cui si può sperimentare tantissimo, fare moltissima ricerca, lavorare sulla tecnologia e i processi, cercando di migliorarli.

E quello con Mutina?

Mi piace definirlo un viaggio empatico ed evolutivo. Con Massimo, abbiamo una bellissima amicizia, condividiamo una grande passione per il nostro lavoro e continuiamo a porci degli obiettivi sempre più grandi. Tutto questo senza smettere di divertirci.

Déchirer has been your first Mutina collection, a groundbreaking project that involved about a year of work. How did it develop?

Déchirer marked the beginning of a wonderful collaboration as well as a profound friendship. With Massimo, we wanted to create a surface inspired by past, imprints of stratifications, juxtapositions of very subtle and irregular decorative perceptions. The remembrance of a torn wallpaper, this is why we called it Déchirer. The project developed starting with the plaster modules, giving birth to a collection that is offered to the designers' sensitivity, who will create a personal vision by playing with its neutral colours, motifs and light.

Déchirer made a turning point in the world of auteur surfaces, paving the way to research and experimentation. What makes it such a timeless and recognisable project also nowadays?

Déchirer is a revolutionary collection, a surface impregnated with memory, like a fossil... Although extremely decorative, it follows a random logic. It's an elegant project, but not redundant, that goes beyond the moment and offers different solutions, thanks to the possibility of alternating smooth and decorated elements. In this way, the surface is constantly perceived differently, depending on the light at different times of day and during the seasons.

It was precisely with this collection and Mutina that you started working with ceramics. How would you describe your relationship with this material today?

To me, working with ceramics is like a marathon, with 100-meter races, high jump and long jump competitions in the middle. It requires patience, a lot of imagination, critic and self-critic. Ceramic is a versatile material, adaptable and extremely resistant. It's a material with which you can experiment a lot and do so much research, as well as working with technology and processes in order to improve them.

What about the relationship with Mutina?

I like to describe it as a journey full of empathy and change. With Massimo, we have a beautiful friendship, we share a great passion for our job and we set increasingly advanced goals for ourselves. All this without ceasing to have fun.

“Déchirer nasce dalla volontà di creare una superficie con l’opacità del cemento, materiale che amo, pur conservando la propria identità di materia ceramica. Lavorando a quattro mani, intervenendo continuamente sul processo creativo e di produzione, riuscendo anche a divertirci”.

“Déchirer comes from the idea of creating a surface inspired by the opacity of concrete, always preserving its identity of ceramic. Working side by side, always taking part into the creative and production process, being also able to enjoying it.”

Patricia Urquiola

Previous page – Déchirer Decor Bianco
Opposite page – Déchirer Decor Bianco

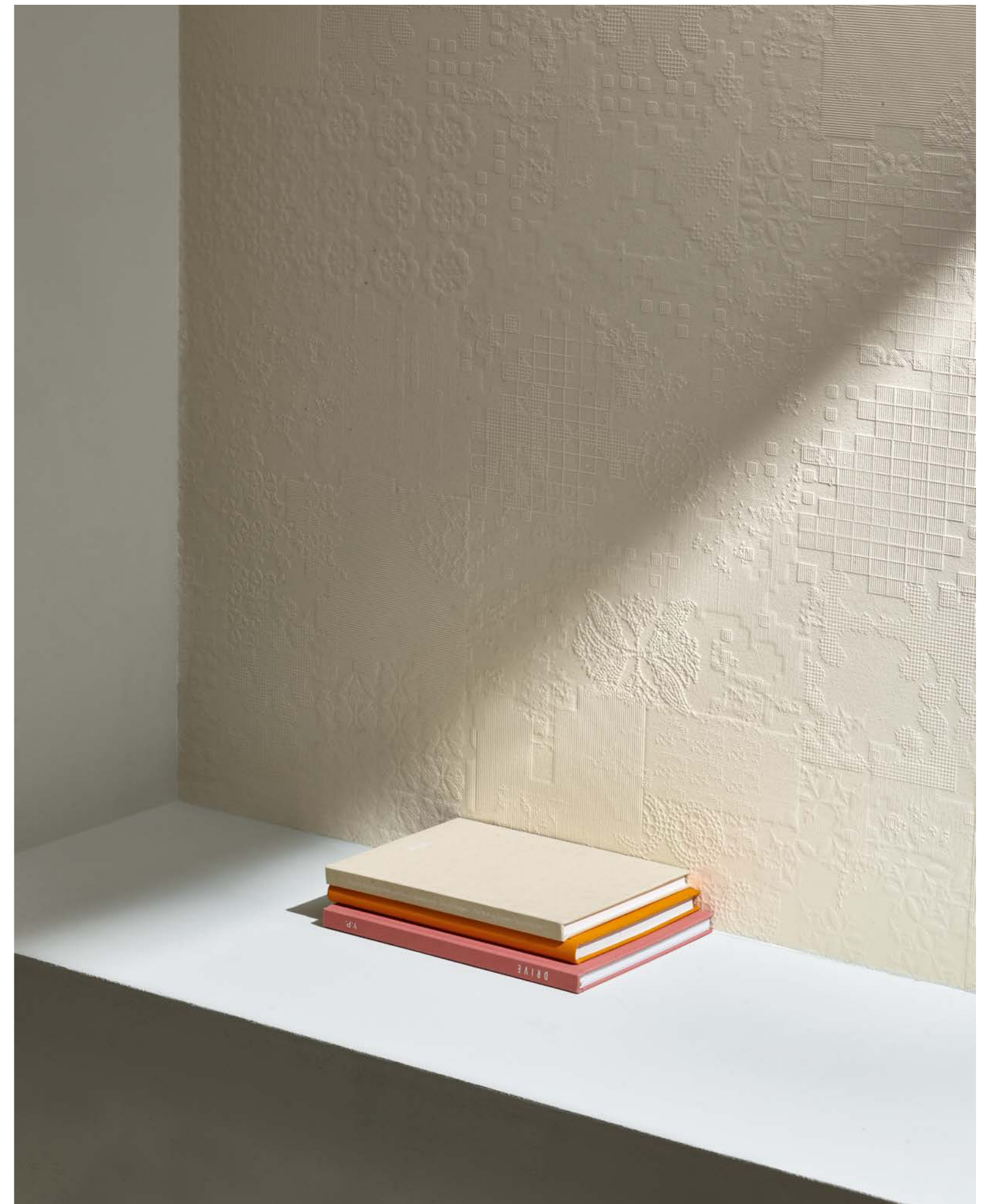

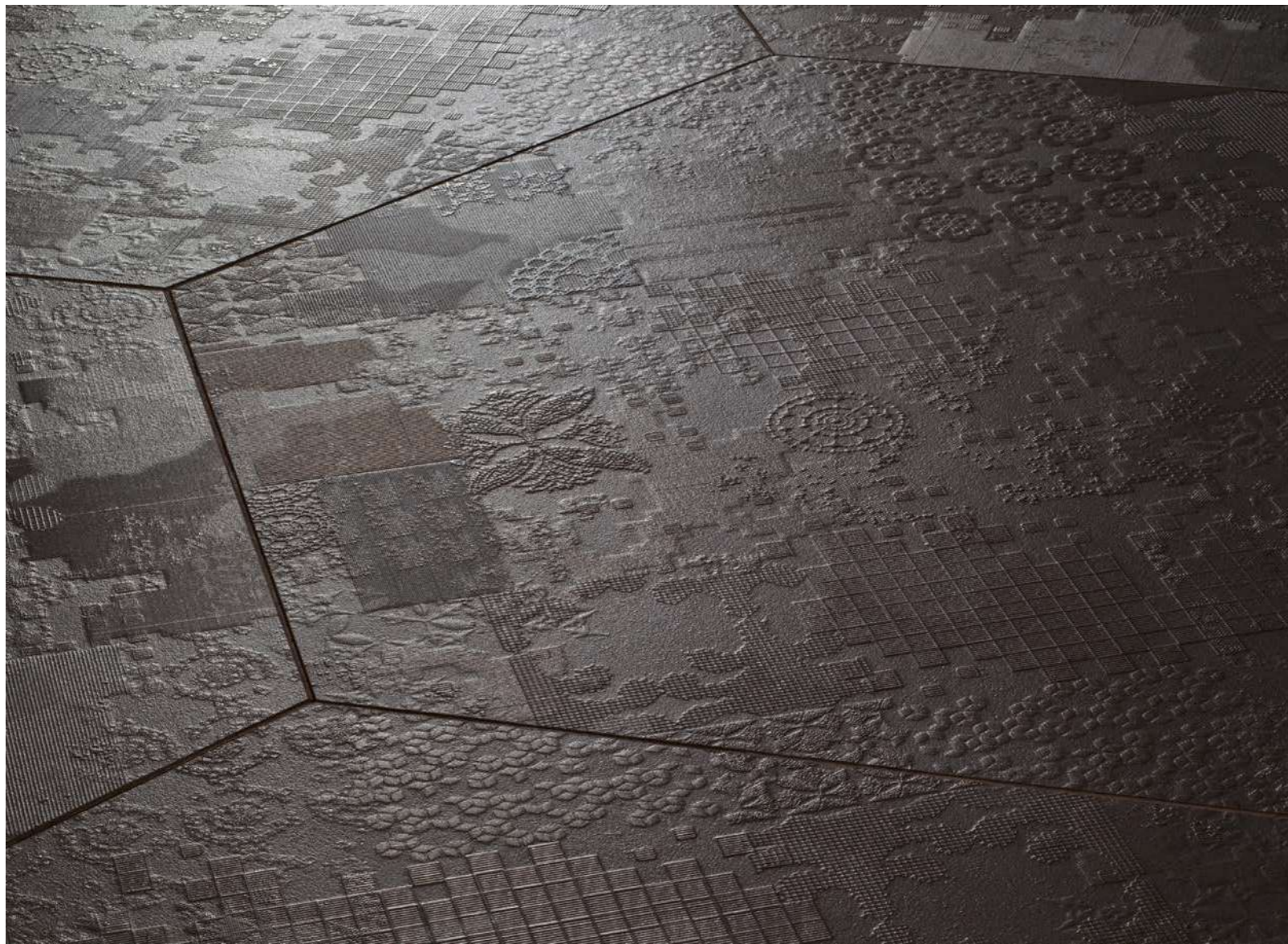

Opposite page – Déchirer Esagona Nero
Déchirer (La Suite) Net Calce



Déchirer^{XL}

Patricia Urquiola

Mutina ha deciso di celebrare il grande successo di Déchirer riproponendo l'emblematica collezione in un nuovo formato XL, che permette ai bassorilievi di svilupparsi su una superficie continua. La versione Decor viene quindi realizzata nella dimensione 100x300 cm e presenta tre colorazioni: Gesso, Grafite e Avana. Le lastre vengono realizzate interamente con un impasto di grès porcellanato non smaltato (UGL) nel minor spessore disponibile (3 mm con fibra) e si adattano perfettamente ad essere utilizzate sia a pavimento che a rivestimento, sia in interno che in esterno. La produzione di Déchirer^{XL} avviene pressando materia pura all'interno di un impianto ceramico di ultima generazione, in questo modo è possibile realizzare strutture su grandi lastre, mantenendo perfettamente definiti i dettagli dei bassorilievi.

Mutina has decided to celebrate the great success of Déchirer by re-proposing the emblematic collection in a new XL size, which allows the bas-reliefs to develop on a continuous surface. The Decor version is made in 100x300 cm size and has three colours: Gesso, Grafite and Avana. The slabs are made entirely with a mixture of unglazed porcelain stoneware (UGL) in the smallest thickness available (3 mm with fiber) and are perfectly suited to be used both on floors and walls, indoor and outdoor. The production of Déchirer^{XL} takes place by pressing pure matter inside a latest-generation ceramic system, so that it is possible to create structures on large slabs, keeping the details of the bas-reliefs perfectly defined.



Opposite page – Dechirer^{XL} Grafite, Avana, Gesso
Dechirer^{XL} Gesso



Diarama

Hella Jongerius

Diarama nasce dalla volontà di dare vita a una collezione caratterizzata da un ampio range di tonalità cromatiche che vengono alla luce in modo del tutto naturale e casuale, attraverso la stratificazione dei colori, così come avviene nei dipinti. È uno studio sul colore puro, applicato su diversi tipi di superfici ceramiche come fosse una seconda pelle. La collezione è composta da diverse reference cromatiche smaltate applicate a 7 basi di argilla colorata e matt. Ogni reference è ricavata dall'applicazione dello stesso smalto ai diversi colori delle basi che reagendo in maniera inedita, va a creare un ventaglio di sfumature sempre nuove, classificate sotto i due macro gruppi denominati Light e Dark. A questi si aggiungono Diarama Black e White dove lo smalto applicato alle 7 basi è rispettivamente nero, Iron, o bianco, Chalk. Usati insieme danno vita a Dusk, la combinazione black & white. Con Diarama Mix, il principio viene ribaltato. Sulla stessa base nera o grigia vengono applicati diversi colori di smalto creando Black Chroma e Grey Chroma. Il risultato finale è quindi sempre diverso a seconda della combinazione tra pasta e smalto. Al centro, una striscia di argilla colorata non smaltata fa da contrasto con il resto della superficie lucida.

Diarama comes from the desire of giving birth to a collection characterised by a wide range of chromatic shades, that come to light spontaneously and randomly by stratifying colours, as happens in paintings. It's a study about pure colour, applied on different ceramic basis like a second skin. The collection is composed by various glazed chromatic references, applied on 7 different matt coloured clay basis. Each reference comes from the application of the same glaze on the top of the several coloured basis, which react in an unpredictable way and create a fan of ever inedit nuances, distinguished in two macro-groups called Light and Dark. These are complemented by Diarama Black and White, where the glaze applied on the 7 basis is respectively black, Iron, or white, Chalk. Combined together, they create the black & white combination: Dusk. Diarama Mix overturns this principle. Different coloured glazes are applied on the same black or grey base, creating Black Chroma and Grey Chroma. Depending on the combination between body and glaze, the result will always be singular. In the middle of the tile, a matt stripe of coloured clay creates a contrast with the polished surface.



“Ho utilizzato le piastrelle come fossero delle tele, così da capire in che modo diversi corpi di argilla colorata avrebbero reagito mettendovi sopra lo stesso smalto. Volevo che la superficie non sembrasse semplicemente colorata, ma mixata, come nella pittura a olio”.

“I’ve used the tiles as canvas, to see how different bodies of coloured clay reacted when a glaze was applied on top of them. I didn’t want the upper surface to simply appear to be coloured, but mixed, as if it were an oil painting.”

Hella Jongerius

Opposite page – Diarama Blush Dark,
Accents Paint: Earth Matt

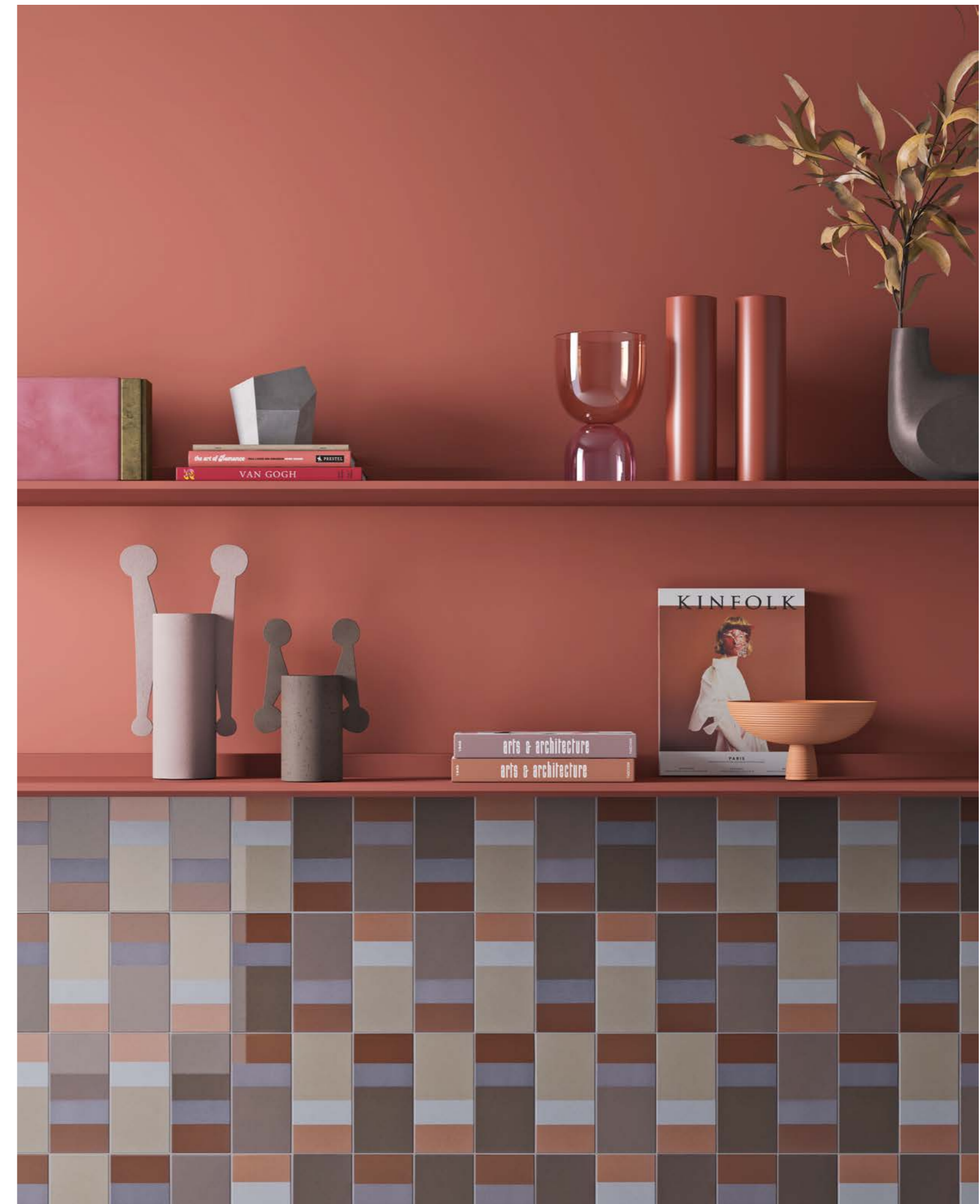

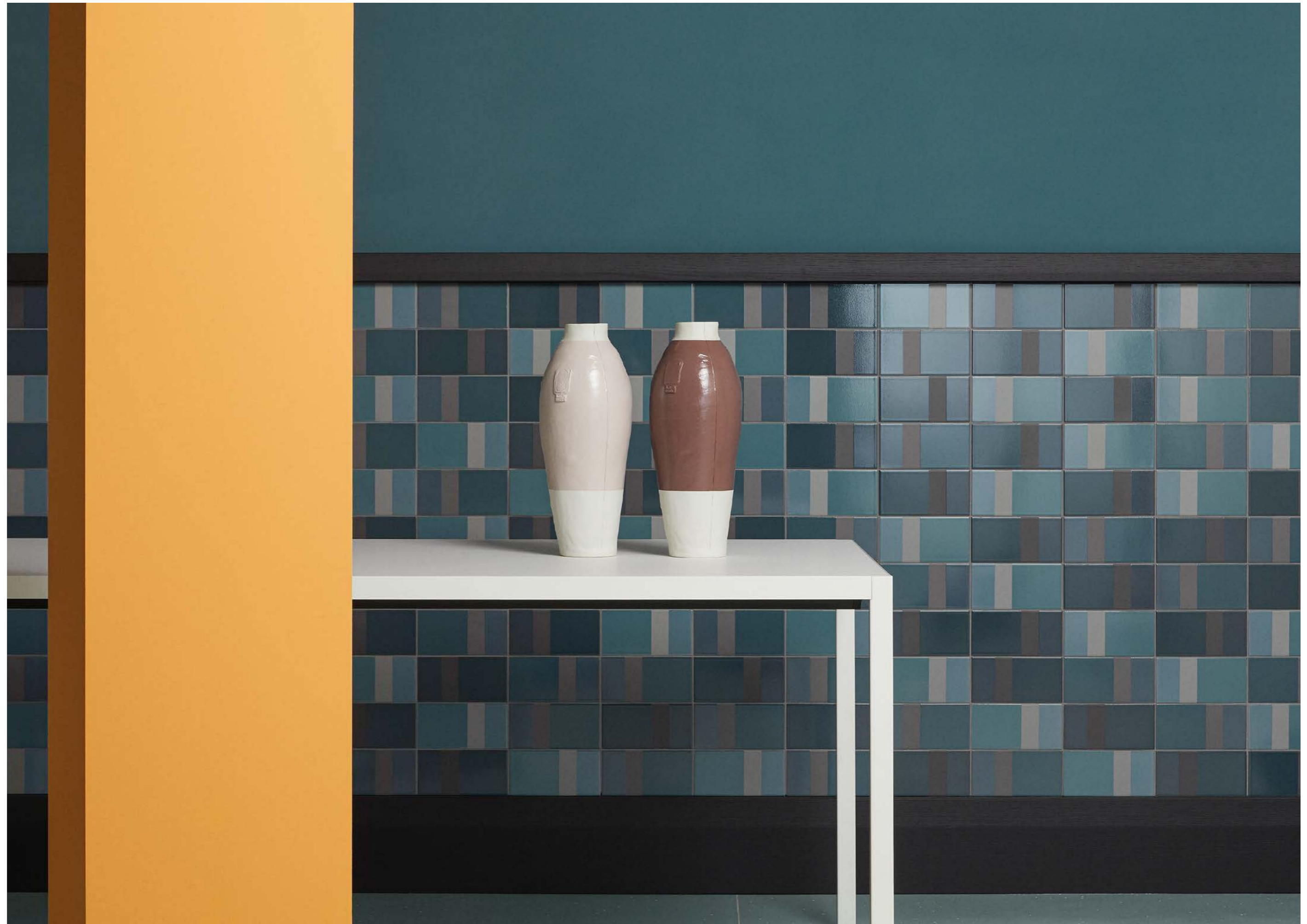



Diarama Blush Light

A conversation with
Hella Jongerius

Come è stata sviluppata la collezione Diarama?

Il processo produttivo si è aperto al colore in modo naturale, perché abbiamo scelto delle superfici in terracotta naturale su cui applicare lo smalto. Abbiamo utilizzato sette diverse basi, mentre lo smalto è sempre lo stesso. Il cambiamento di colore è determinato dal gioco tra i materiali, l'interazione tra i vari tipi di terracotta e il colore. Le superfici hanno reagito in modo completamente diverso allo smalto, creando una palette di colori inaspettata.

Che tipo di relazione hai con le piastrelle?

Mi piace che possano essere usate in tanti modi diversi. Ci sono infinite possibilità di applicazione. Le persone sono libere di scegliere dal panorama che abbiamo creato con Diarama. Il prodotto è per metà composto dalle texture che abbiamo scelto, ma prenderà vita grazie ai clienti, agli interior designer e agli architetti. Saranno loro a scegliere che tipo di linguaggio si adatterà meglio agli elementi. Mi piace molto questo aspetto.

Per quale motivo il tuo lavoro è così concentrato sul colore?

Per me, il colore è un materiale. Come industrial designer, ho capito che non avrei potuto usare tutte le tonalità che avrei voluto, come fa un artista, perché la palette utilizzata dall'industria è ristretta, stabilizzata, non reagisce alla luce. Volevo di meglio. Volevo riportare la qualità nel mondo dei colori per noi designer, ed è per questo che ci lavoro così intensamente: voglio farli respirare con la luce.

Ricordi la prima volta che sei entrata in contatto con l'azienda e hai incontrato il team Mutina?

Ricevetti una telefonata da Massimo e pensai "Perché no? Incontriamoci". Pensavo che sarebbe venuta una sola persona, invece mi ritrovai l'intera famiglia! Alla fine eravamo in tanti seduti intorno al tavolo, abbiamo avuto una conversazione piacevole. Ma avevo bisogno di capire se ci fosse la giusta chimica. Dopo un po', iniziai a sentirmi a mio agio e a pensare che fosse l'azienda giusta. Decisi che potevo condividere il progetto ceramico a cui stavo lavorando in quel periodo, sovrapponendo i colori sulla terracotta. Piacque molto a Massimo, disse che era esattamente quello che stava cercando. Fu un incontro naturale, intellettuale.

How did the project of the Diarama collection developed?

The production process naturally opened up to colour, because we have chosen natural clay bases to which the same enamel is applied. We used seven different clays but kept the colour of the enamel the same. The change in colour is determined by the play between materials, the interaction between the changing base and an unchanging colour. The surfaces reacted completely differently to the enamel, creating a palette of colours that we didn't expect.

What kind of relationship do you have with tiles?

What I like about the tiles is that you can use them in so many different ways. There are endless options. People are free to choose from the panorama that we have created with Diarama. The product is half-composed of the chosen textures, it then comes to life thanks to the clients, the interior designers and architects. They can all decide which language fits them best. That is what I love.

Why is your work so concentrated on colour?

Colour is a material to me. As an industrial designer, I realised that I wouldn't be able to use all the tones I wanted to, in the way an artist does, because the palette used in the industry is very limited. It is stable, it doesn't respond to light. I wanted more. I wanted to bring quality back to the world of colours for us designers and that is why I work so intensely with them: I want them to breathe with light.

Do you remember the first time you got into contact with the company and met the Mutina team?

I received a phone call from Massimo and I thought, "Why not? Let's meet up." I was expecting one person and he arrived with the whole family! In the end there were lots of people sat around the table and we had a pleasant conversation. But I needed to see whether we had the right chemistry. After some time, I began to feel at ease and to think it was the right company. I decided I could share the ceramic project I was working on at that time, layering colour over clay. Massimo really liked it, he said it was exactly what he had been looking for. It was a natural, cerebral encounter.

Opposite page – Diarama Ash Dark, Accents Paint: Slate Satin
Diarama Dusk, Accents Paint: Coal Satin



Din

Konstantin Grcic

Din costituisce una nuova interpretazione del mosaico moderno. La collezione è stata concepita secondo una specifica logica modulare, che permette di giocare con gli elementi e offre infinite possibilità di applicazione, passando dai concept più semplici a quelli più elaborati, dimostrando una versatilità pressoché illimitata. La collezione presenta 4 elementi nelle misure 15x15 cm, 7,4x15 cm, 7,4x7,4 cm e 3,6x7,4 cm, modulari fra loro con una fuga di 2 mm, declinati in un range di 8 colorazioni e 2 finiture, opaca e lucida, per un totale di 64 elementi. La possibilità di accostare diversi formati, texture e colori garantisce non solo un incredibile potenziale creativo, ma anche di poter adattare lo schema di posa alle dimensioni specifiche di pavimenti e rivestimenti. Din si sviluppa inoltre nella tridimensionalità, offrendo una gamma di 6 pezzi speciali che permettono di rivestire ogni angolo delle superfici.

Din represents a complete new way of conceiving a modern mosaic. The collection is conceived in a strictly modular logic that allows to play with the elements and offers a wide scope of possible applications, from simple concepts to the most complex ones, demonstrating an almost unlimited flexibility. Din presents 4 elements in the sizes 15x15 cm, 7,4x15 cm, 7,4x7,4 cm and 3,6x7,4 cm, declined in a range of 8 colours and 2 finishes, matt and glossy, for a total of 64 ceramic tiles. The four sizes are modular, with a joint of 2 mm. The possibility to combine several formats, textures and colours guarantees not only a great creative potential, but also that the tile pattern can be adapted to the dimension of a specific wall or floor. Din also develops into the third dimension, offering a range of 6 special pieces for angles and profiles.

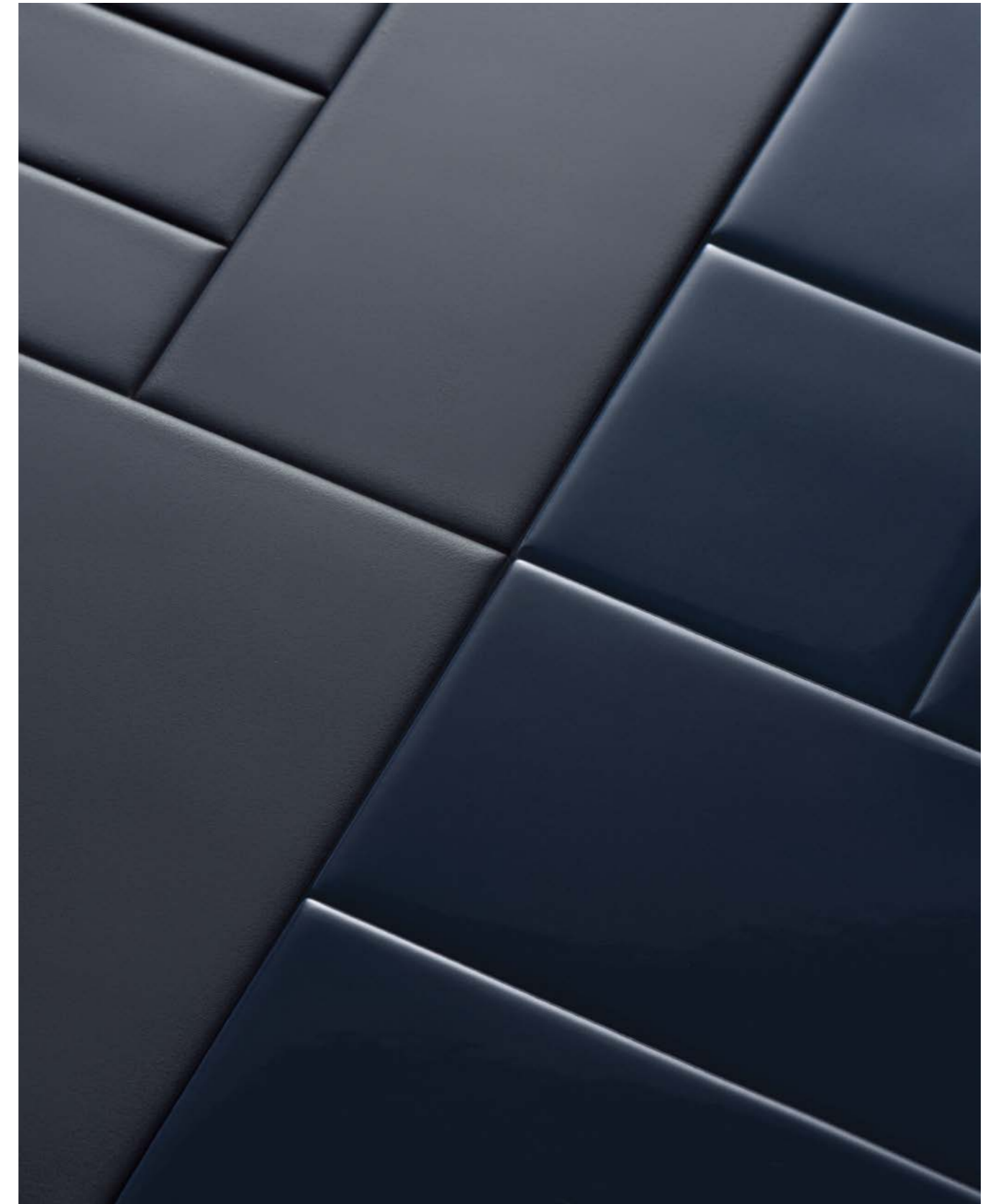

Wall: Din White Glossy,
Black Matt - in different sizes

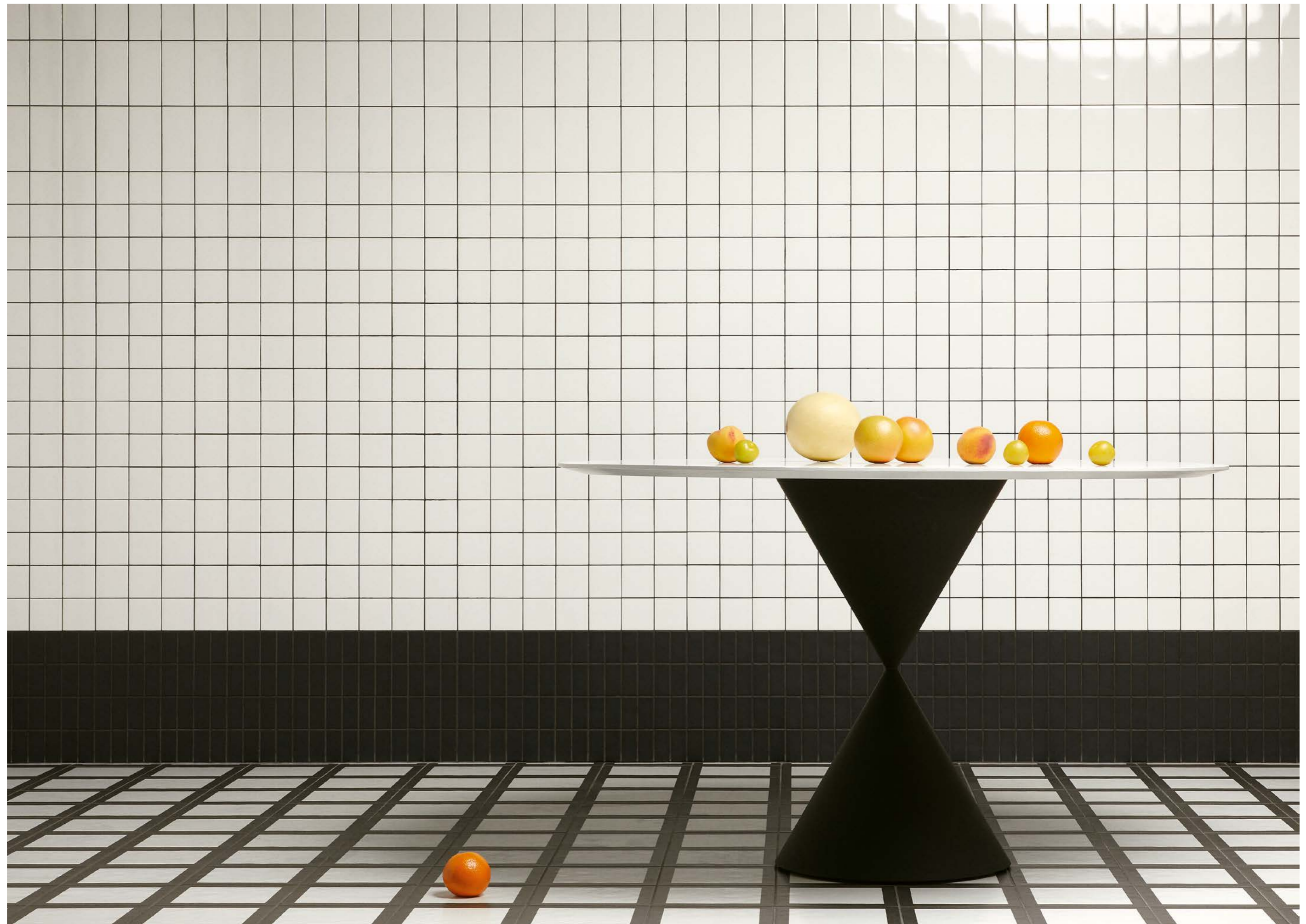

Wall: Din Dark Blue Matt. Floor: Din Dark Blue Glossy – in different sizes.



Wall: Din Black Matt, Black Glossy – in different sizes.

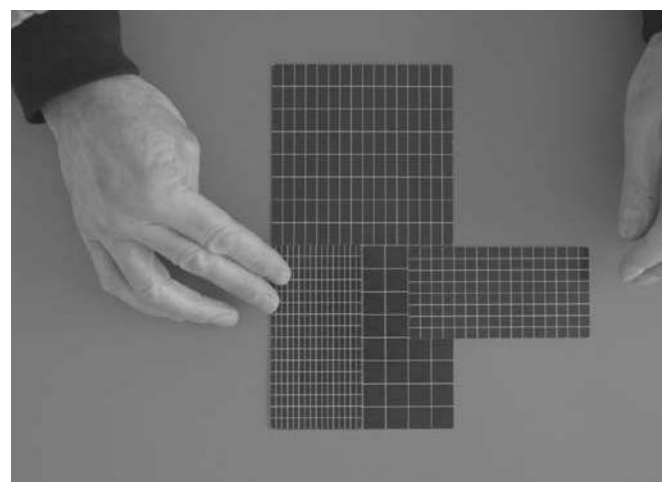

Si potrebbe parlare di Din come di una nuova interpretazione del mosaico moderno. Cosa ne pensi? Sei d'accordo con questo suggerimento di utilizzo?

Sì, assolutamente. Da esterno, credo che il mio approccio sia basato sul cercare l'essenza delle piastrelle. Mi affascina che questo piccolo elemento ceramico, una volta moltiplicato, diventi un muro o un pavimento. È un elemento architettonico che permette di costruire e realizzare spazi. Con "realizzare" intendo non solo la struttura fisica di uno spazio, ma anche l'atmosfera, gli aspetti legati alle emozioni e alla bellezza, la sua leggibilità. Si tratta di creare veri interni di qualità.

Din offre non solo una gamma di rivestimenti ceramici per pavimenti e rivestimenti, ma si sviluppa anche tridimensionalmente, con mobili fatti interamente di piastrelle. Come è stata implementata questa idea nel progetto?

Il progetto si è sviluppato a partire da un concept essenziale. Din doveva essere una collezione molto semplice e razionale, poi si è evoluta raggiungendo nuove dimensioni. Mi ha sorpreso la facilità con cui è successo. Abbiamo iniziato costruendo oggetti astratti di forma cubica, ma ora possiamo realizzare dei veri mobili, qualcosa di davvero unico.

La superficie degli elementi dà l'idea che, pur essendo prodotti industriali, siano stati lavorati a mano. La tradizione ceramica è stata il punto di partenza per ottenere questo effetto, o viceversa?

Il merito è di Mutina e, soprattutto, dei forti input di Massimo. È lui l'esperto, colui che sa tutto riguardo la ceramica. Ha trasformato la collezione in modo tale che la superficie degli elementi trasmettesse vitalità e profondità, nonostante fossero prodotti industriali. L'aggiunta di questo tocco artigianale ha creato un bellissimo contrasto con la razionalità di Din. Credo che, in fin dei conti, sia questa la magia della collezione.

Questa è stata la tua seconda collaborazione con Mutina e, più in generale, la tua seconda esperienza con le superfici ceramiche. Come si è evoluto il rapporto con l'azienda e com'è stato lavorare con il team?

Credo che abbiamo un rapporto davvero speciale e parte di questo legame è dato dal fatto che, oltre al progetto in sé, ci sono tanti altri punti di riferimento. Con Massimo è l'arte contemporanea, ma anche l'umorismo, la creatività, gli aspetti culturali e sociali... credo che li condividiamo tutti.

Din could be perceived as a complete new way of conceiving a modern mosaic. How do you feel about this possibility? Do you agree with this usage suggestion?

Yeah, absolutely. As an outsider, I think that my approach is based on trying to get to the essence of tiles. I'm fascinated by the fact that it's a little piece of ceramic but, in multiplication, it actually becomes a wall or a floor. It's an architectural element for building and making spaces. When I say "making spaces", it comprehends not only the structural creation of a space, but also the atmosphere, the emotional aspects and the beauty of it, its legibility. It's about giving spaces a real quality.

Din not only provides ceramic coating for floors and walls, but it eventually develops into the third dimension with pieces of furniture entirely made of tiles. How did this idea grow into the project?

We started working on this project with a very elementary concept in mind. Din was meant to be a simple and rational collection and then it developed into other dimensions. I was surprised by how easily that happened. We started by building abstract cubical things, but now we can create actual furniture, something that is a real staple.

The surface gives the feeling that, even through an industrialized process, the elements are handcrafted. Was ceramic tradition the starting point, or the other way around?

I give credit to Mutina and especially to Massimo's strong input. He's the expert, the one who knows everything about ceramic. He twisted it in such a way that, even though the elements are industrially made, the surface is alive and has a depth. Adding an artisanal touch is a beautiful way to contrast the hard, rational idea of Din. I think that, in the end, that's probably the magic of it.

This has been your second venture with Mutina, your second experience with tiles in general. How the relationship with the company has developed and how's working with them?

I think we have a really special relationship and a part of this bond is that, beyond a project, there are so many other points of reference. With Massimo it's contemporary art, but there's also humor, creativity, the cultural and the social sides... and I think we share all of them.

“I diversi formati di DIN si inseriscono tutti nella stessa griglia. E si possono combinare per creare diverse geometrie, superfici e pattern. Mi piace pensare che una piastrella sia la più piccola unità di una griglia architettonica... Il piccolo quadrato all'interno di una scatola, all'interno di una scatola”.

“The different sizes of DIN all fit into the same grid. And they can be combined to create a variety of geometries, surfaces, patterns. I like to think of a tile as the smallest unit in an architectural grid... The little square inside the box inside the box.”

Konstantin Grcic

Opposite page – Wall: Dark Green Matt, Dark Green Glossy.
Floor: Dark Green Matt – in different sizes.





Flow

Mutina Team

Flow nasce dall'idea di conservare sulla superficie della materia ceramica le tracce del proprio processo di creazione, dando vita a un prodotto allo stesso tempo sobrio ed elegante, contemporaneo e informale. Un percorso che inizia con l'atto forse più significativo e spettacolare, ovvero il momento della colata negli stampi, da cui derivano la texture e la trama irregolare di questi rivestimenti in formato 30x120 cm e 15x120 cm.

In Flow, l'eterogeneità diventa valore aggiunto attraverso la riproduzione di giochi di luce che catturano lo sguardo, invitandolo a ripercorrere i flussi e la circolarità riprodotte sulle superfici ceramiche, recuperandone l'imprinting originario. Grazie alle caratteristiche estetiche e tecniche, la collezione è adatta alla posa su pavimenti e rivestimenti, sia interni che esterni.

Flow is born from the idea of preserving the traces of the creation process on the surface of the ceramic material, creating a product that is at once sober and elegant, contemporary and informal. A path that begins with perhaps the most significant and spectacular act, that is the moment of casting in the molds, from which the texture and the irregular weft of these coverings in 30x120 cm and 15x120 cm sizes derives.

Heterogeneity becomes added value in Flow by reproducing plays of light that catch the eye, inviting it to retrace the flows and circularity reproduced on the ceramic surfaces, recovering their original imprinting. Thanks to its aesthetic and technical characteristics, the collection is suitable for floors and walls coverings, both indoors and outdoors.

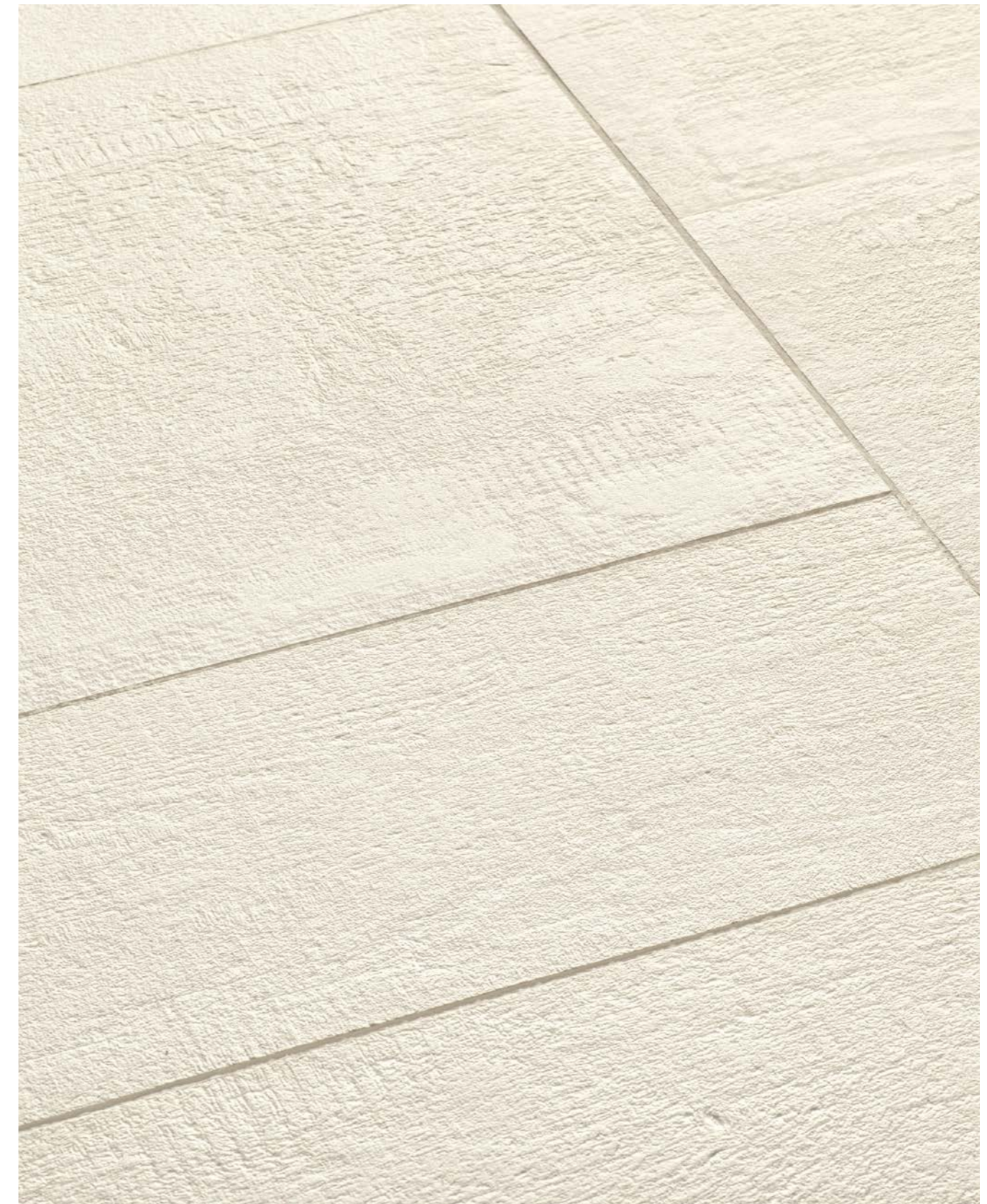



Opposite page – Flow White
Flow White



Folded Raw Edges

Folded trae ispirazione dai pattern ceramici tradizionali che erano – e sono tuttora – presenti negli appartamenti di Tel Aviv degli anni Cinquanta e Sessanta, giocati sulla ripetizione e sull'alternanza cromatica. Da qui è nata la volontà di riprodurre gli effetti della carta piegata su un materiale come la ceramica, realizzando elementi in un singolo formato di 60x60 cm caratterizzati da una palette di toni neutri e delicati. Con Folded, i designer hanno voluto restituire il fascino intrinseco della tradizione architettonica israeliana attraverso la ripetizione modulare di linee semplici, quasi elusive. La luce colpisce la trama delle piastrelle creando eleganti chiaroscuri che ripercorrono l'intera superficie, dando vita a composizioni decorative dall'aspetto contemporaneo, adatte alla posa sia a pavimento che a rivestimento.



“La carta è un materiale con cui ci piace molto lavorare, è versatile, accessibile e, quando è segnata o piegata, la superficie diventa affascinante e piacevole al tatto. Le piastrelle di Folded riproducono queste caratteristiche e creano una tensione tra l'estetica delicata della carta e la durezza della ceramica”.

“Paper is a material we consistently enjoy using throughout our work. It's versatile, accessible, and when it is scored and folded its surface turns beautiful and tactile. Folded tiles translate these qualities of paper into ceramic and create tension between the delicate appearance of paper and the durability of the ceramics.”

Raw Edges

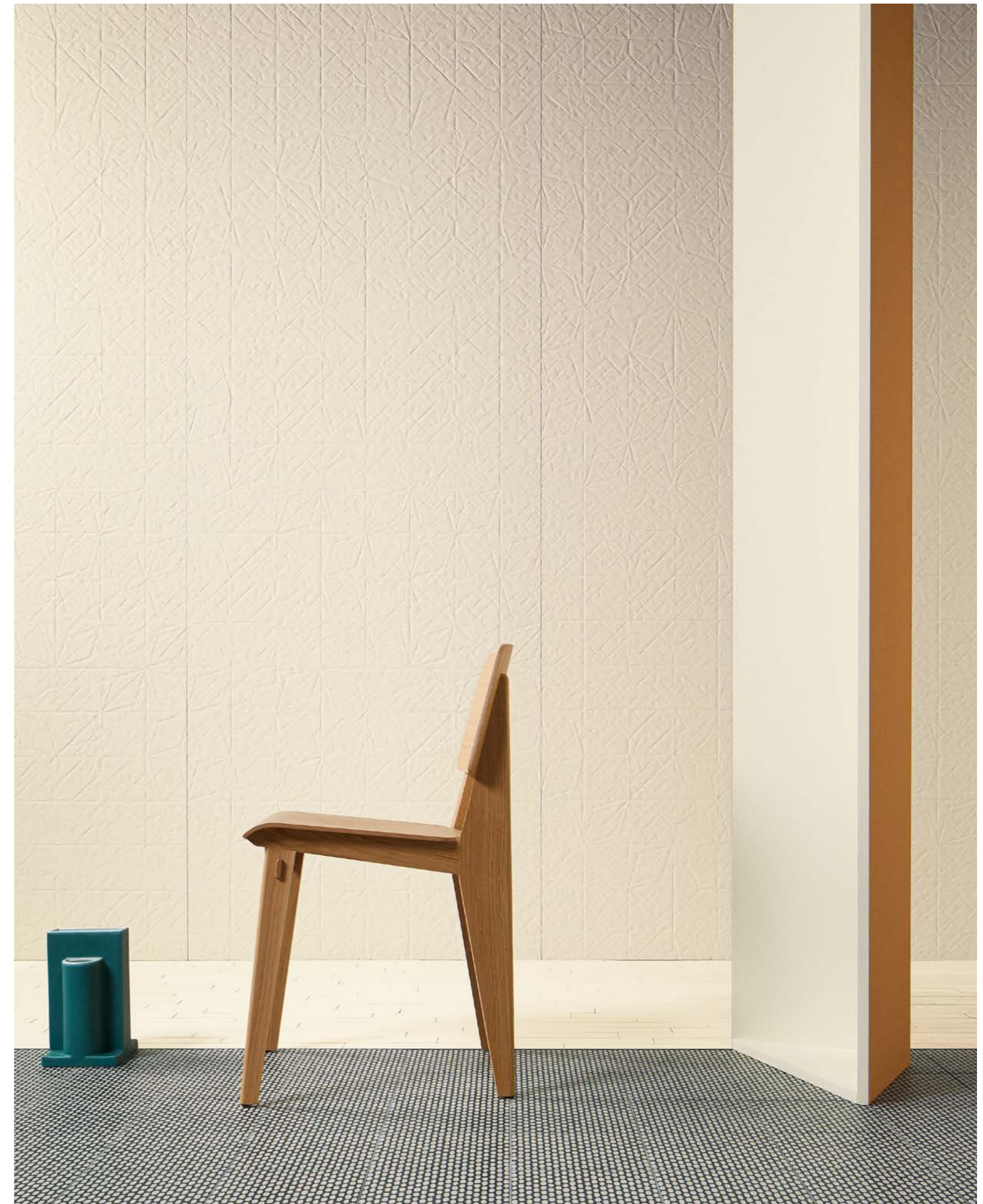

Folded

Raw Edges

143

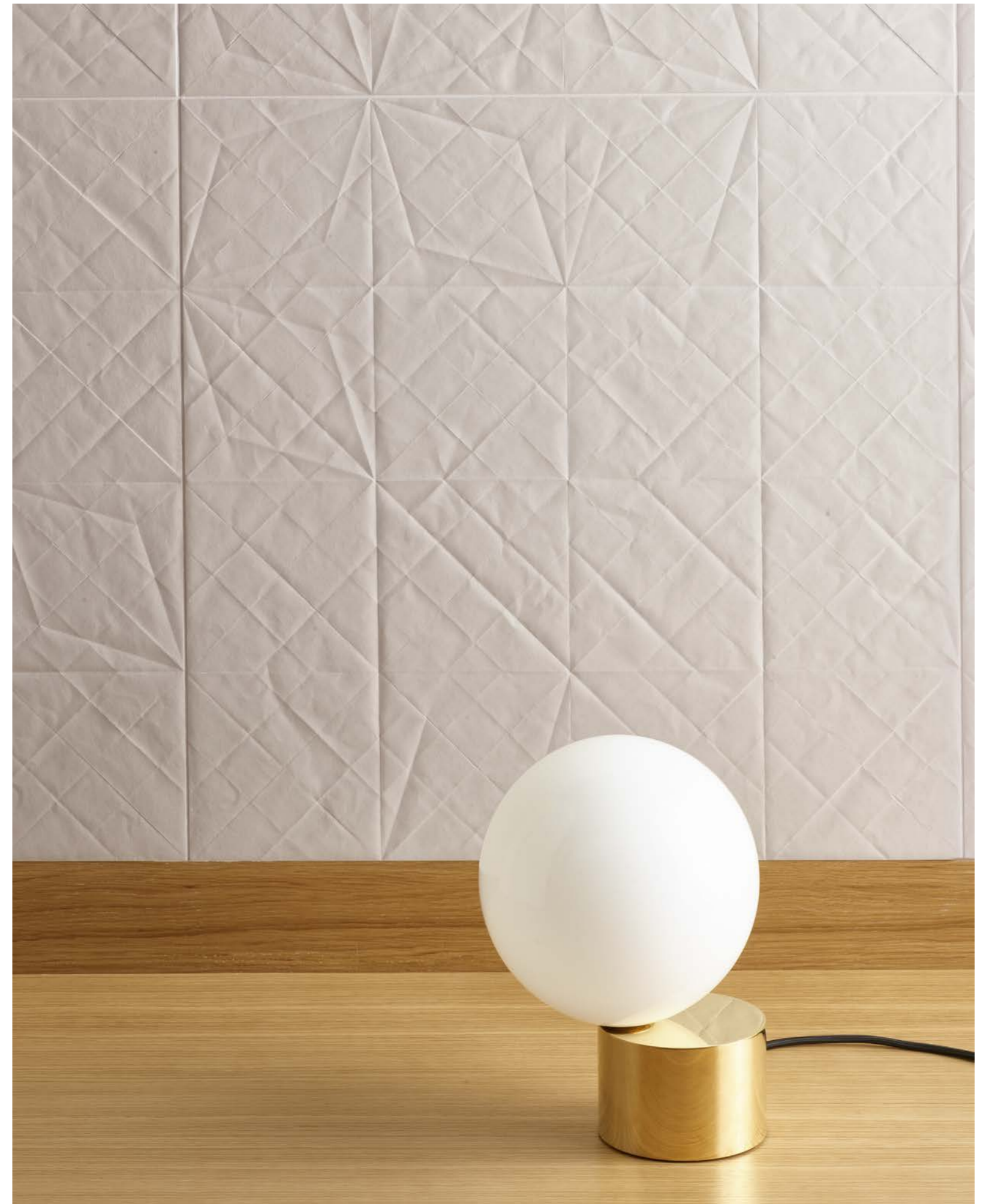

Folded^{XL} Raw Edges

Folded^{XL} ripropone l'effetto della carta piegata dell'omonima collezione, ma in un grande formato di 100 x 300 cm, con uno spessore di 5,6 mm. La nuova collezione è realizzata interamente con un impasto extra white di grès porcellanato, senza l'ausilio di smalti o coloranti. Folded^{XL} è materia pura pressata in un impianto ceramico di ultima generazione che consente, per la prima volta, di realizzare strutture a rilievo su lastre di grandi dimensioni. Folded^{XL} è adatta a una posa a pavimento e a rivestimento, per interni ed esterni, in quanto le sue caratteristiche tecniche di prodotto UGL (unglazed – non smaltato) superano ampiamente i limiti prescritti dalle norme internazionali previsti per i grandi formati.

Folded^{XL} has the same effect of folded paper of the collection of the same name, but in a larger size: 100 x 300 cm, with a thickness of 5,6 mm. The new collection is made entirely in an extra white body of porcelain stoneware, without the addition of glazes or colouring agents. Folded^{XL} is made from pure ceramic matter, which is then pressed in a latest generation machine that makes it possible, for the first time, to create textured surfaces even on large slabs. Folded^{XL} is suitable for both floor and wall tiles, for indoor and outdoor use, as its technical characteristics well exceed the limits prescribed by the international standards for large, unglazed slabs.

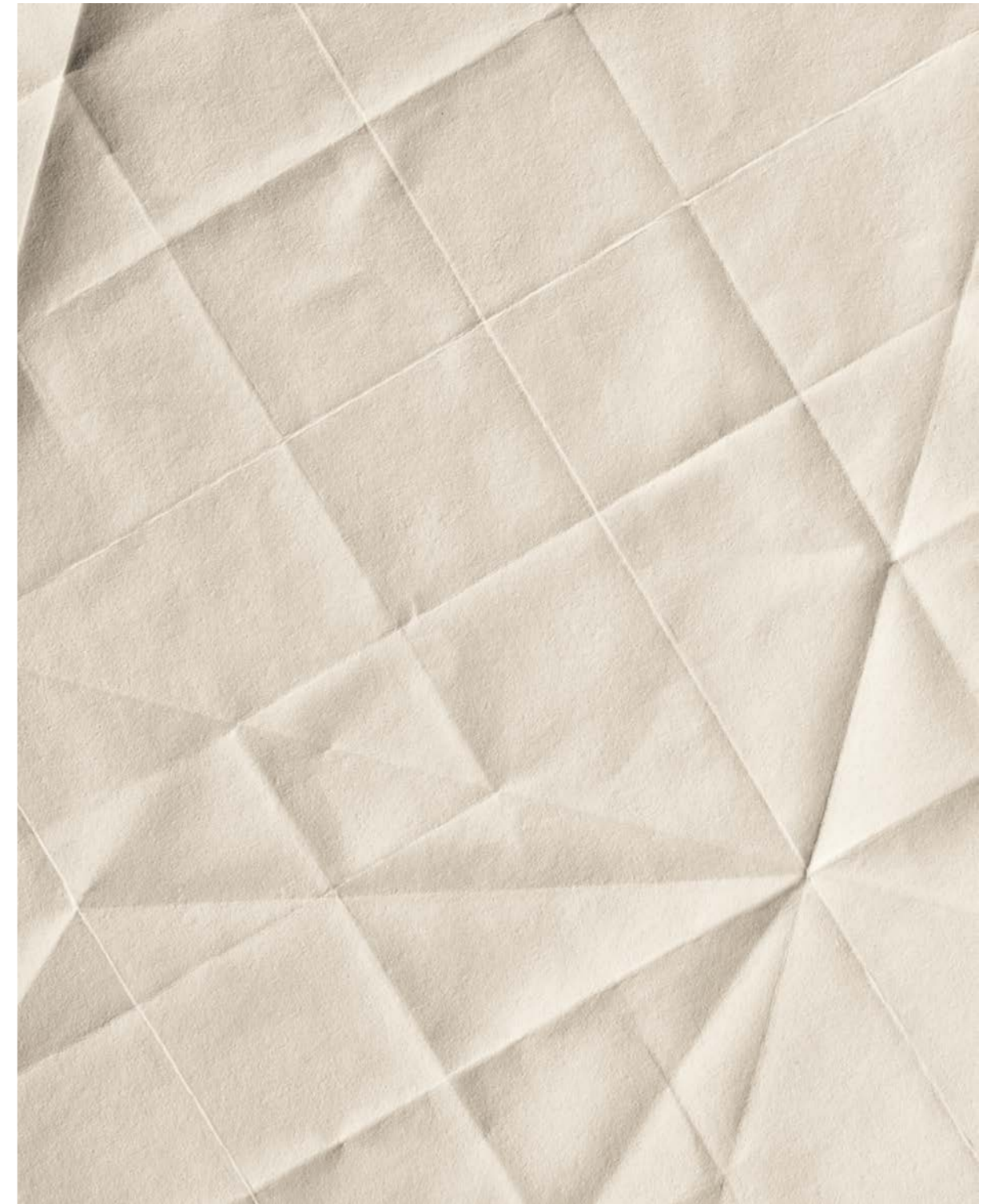





MISSUMASS
301X26X233

PACKED AND SHIPPED
BY



KNAIB
INTERNATIONAL ART MOVERS

Kosei

Vincent Van Duysen

Con Kosei – che in giapponese significa composizione – Vincent Van Duysen propone un range di superfici ceramiche realizzate con l'utilizzo di materiali puri e tattili, ispirate alle rocce laviche, come le ossidiane e i vetri vulcanici, omogenei, amorfi e dalla notevole durezza. Il risultato finale è un design senza tempo, pensato per la grande architettura, ed estremamente versatile, grazie a 8 formati e 5 colori che possono essere accostati per creare infinite combinazioni dal gusto gradatamente decorativo. Kosei è pensata specificamente per essere utilizzata a pavimento, sia in interno che in esterno. La collezione comprende una vasta gamma di elementi: i formati 60x180 cm, 60x90 cm, 60x60 cm, 15x90 cm, 15x60 cm, 15x30 cm e 15x15 cm sono perfettamente modulari fra di loro e presentano una texture morbida; in più è stato creato il formato Chevron nelle misure 9,6x56,5 cm ed è pensato per conferire maggiore profondità alle superfici. I numerosi formati permettono di realizzare superfici eleganti con finitura opaca, ma anche di giocare con la creatività: scegliendo uno o più formati e alternando i colori proposti dalla palette – Bone, Storm, Terra, Grey Green e Dark Grey – si possono creare pattern armoniosi e dinamici, molto diversi tra loro.

With Kosei – which means composition in Japanese – Vincent Van Duysen proposes a range of ceramic surfaces developed with pure and tactile materials, inspired by lava rocks such as obsidian and volcanic glasses, which are homogeneous, amorphous and with exceptional hardness. The end result is a timeless design conceived for “grand” architecture, characterised by extreme versatility thanks to the 8 formats and 5 colours that can be matched to create infinite combinations with a progressively decorative taste. Kosei has been specifically conceived for floors, both indoors and outdoors. The collection features a wide range of elements: the 60x180 cm, 60x90 cm, 60x60 cm, 15x90 cm, 15x60 cm, 15x30 cm and 15x15 cm formats are perfectly modular with each other and have a soft texture; in addition, the Chevron format, available in size 9,6x56,5 cm, has been created to lend depth to surfaces. The numerous elements make it possible to design elegant matt surfaces, but also allow for creativity: by choosing one or more formats and alternating the 5 available colours – Bone, Storm, Terra, Grey Green and Dark Grey – it is possible to create different harmonious yet dynamic compositions.

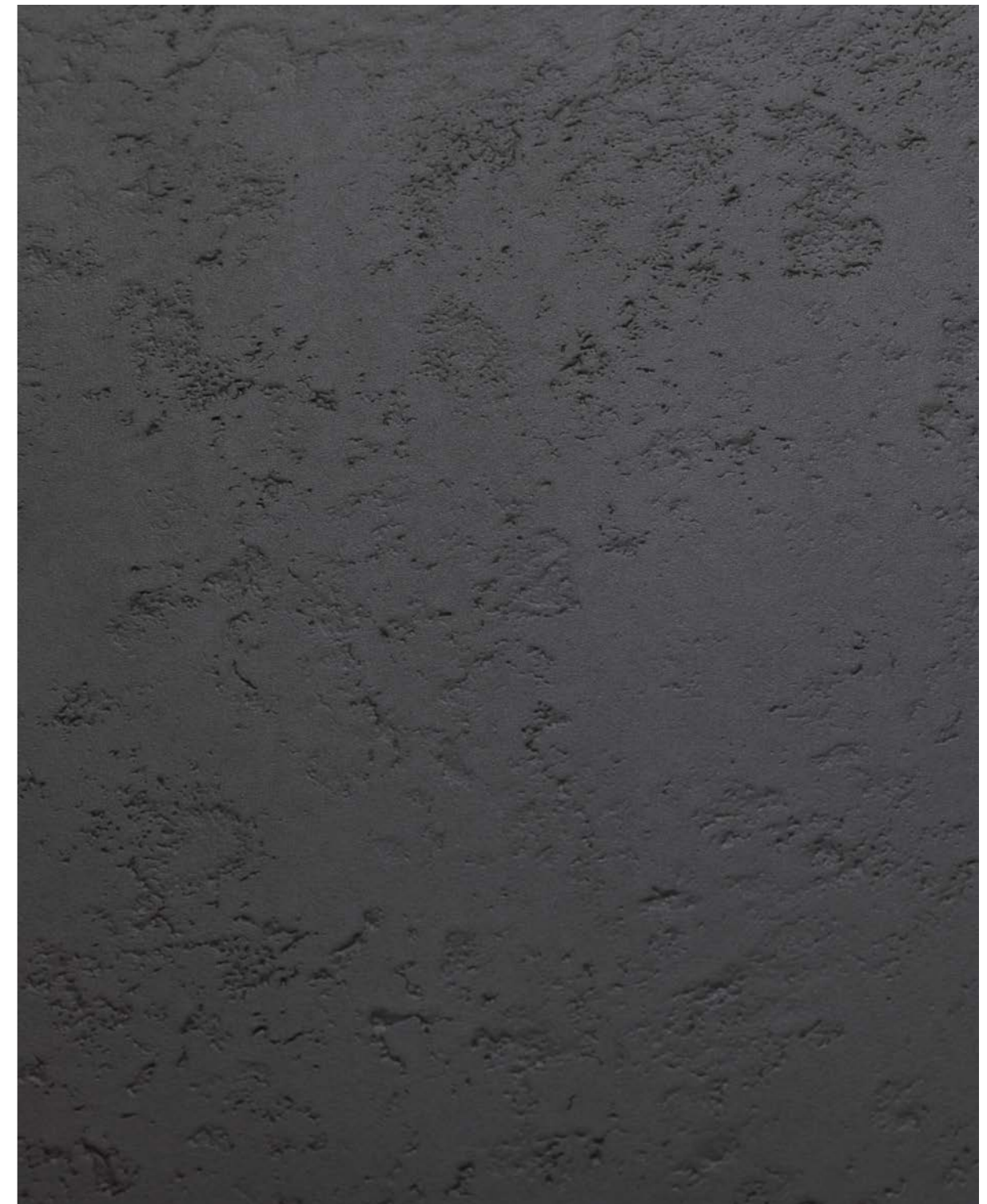



Kosei Terra
Next page – Kosei Dark Grey, Bone

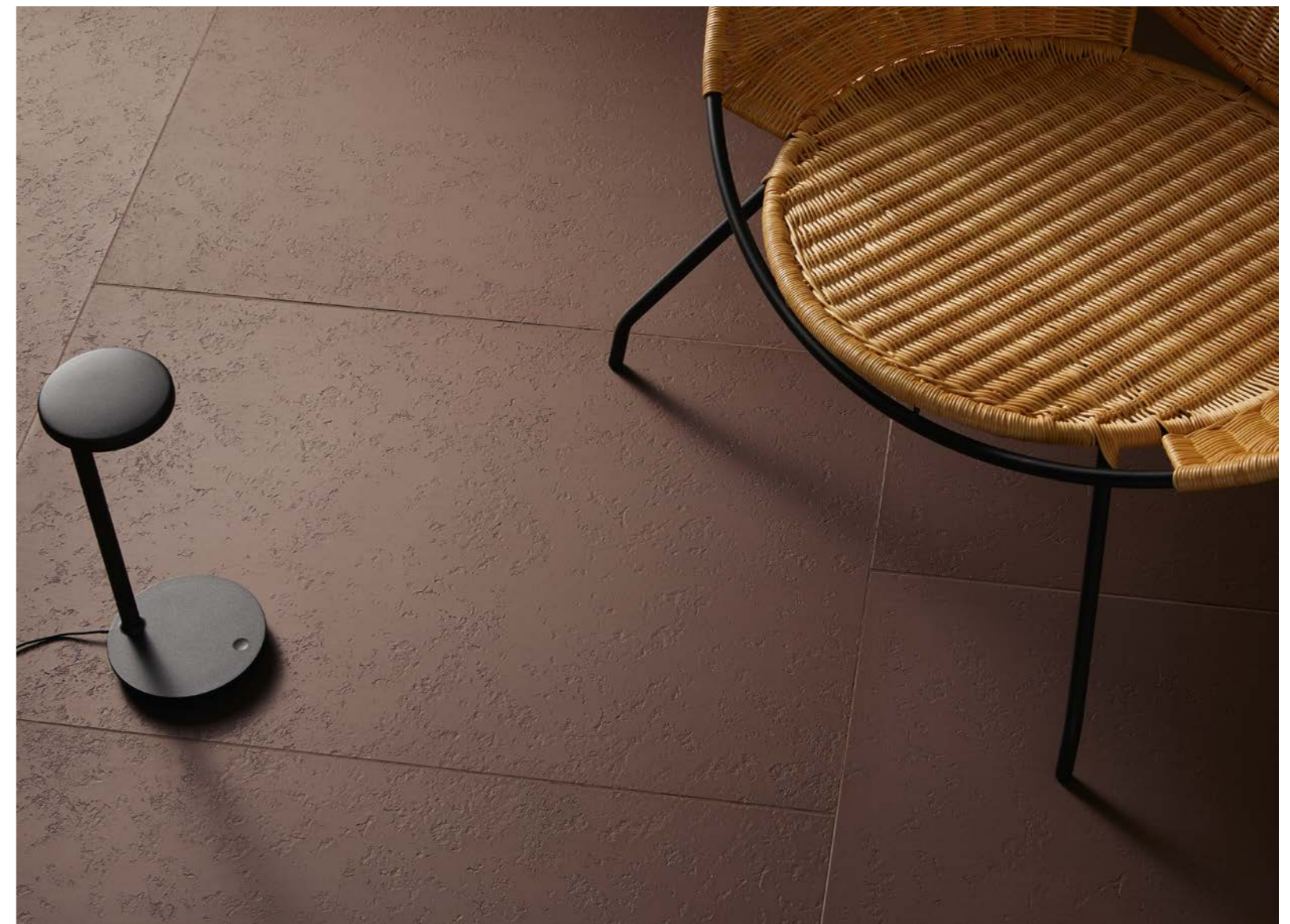

Kosei Dark Grey, Bone



Ti ricordi la prima volta che sei entrato in contatto con Mutina? Come si è sviluppato il vostro rapporto?

Ci conosciamo da diverso tempo e abbiamo sempre mantenuto un bel rapporto di amicizia nel corso degli anni. Massimo e io condividiamo la stessa passione per l'arte, è questo che ci connette. Dopo tutti questi anni, abbiamo finalmente trovato il momento giusto per iniziare a collaborare. È successo in modo naturale, realizzando delle collezioni ampie, capaci di rappresentare entrambi i nostri mondi.

Che tipo di approccio hai con una materia terrosa come la ceramica?

Per me la ceramica è un materiale molto tattile, molto sensuale. Chiede di essere toccata, ma anche contemplata. Bisogna sempre considerare come interagisce con la luce: è una combinazione di elementi naturali. La texture della ceramica cambia continuamente e rivela diversi aspetti a seconda del momento della giornata. Tutti questi fattori contribuiscono a dare un'ampia gamma di possibilità creative.

La tua collaborazione con Mutina è iniziata con tre progetti, tra cui Kosei. Cosa volevi ottenere, in termini di estetica e significato, con questa collezione?

Con Kosei volevo approfondire la storia dei pattern legati al mondo dell'architettura. Abbiamo sviluppato diversi pattern che assumono un aspetto diverso semplicemente modificando il colore di alcuni pezzi. Questo permette di dare letture diverse alla stessa collezione. Si può passare da un layout omogeneo a uno molto ritmato e grafico. È un progetto versatile, che strizza l'occhio alle nozioni dei diversi punti di vista che tutti possiamo avere rispetto all'architettura.

Potresti spiegare più nel dettaglio che significato ha per te la natura, a un livello profondo, e come ti relazioni ad essa?

Un po' di tempo fa, ho iniziato a praticare la meditazione trascendentale. Mi aiuta a connettermi alla mia vera natura, al mio corpo e alla mia mente, ma anche all'universo intorno a me. La natura intrinseca delle cose mi ispira molto, perché può insegnarci tanto. È un concetto che porto sempre con me e che cerco di trasmettere attraverso i miei progetti, grazie ai materiali che uso o con l'atemporalità del mio lavoro.

Do you remember the first time you got in touch with Mutina and how your relationship developed?

We've been knowing each other for quite some time and we have always maintained a friendly relationship over the years. Massimo and I share the same passion for art in general. That's what connects us. After all these years, we finally found the right moment to start collaborating. It came naturally, making the collections generous and representative of both our worlds.

What is your approach with an earthy matter such as ceramics?

Ceramic is a very tactile material for me, very sensual. It calls for touch but also for contemplation. One must always consider how light interacts with this material: it is a combination of natural elements. The texture of the ceramic is changing and reveals itself in a different way depending on the time of day. All these factors give you a wide range of creative possibilities.

Your collaboration with Mutina begun with three projects, among which there is Kosei. What do you want to achieve, in terms of aesthetics and meaning, with this collection?

For Kosei, I wanted to go deeper into the history of patterns linked to the world of architecture. We developed several patterns that reveal themselves in different ways just by changing the colour of certain pieces. This gives us different readings of the collection. We can go from a very homogeneous look to a very rhythmic and graphic one. It's a very versatile collection, that comes close to the notions of different points of view that we can all have about architecture.

Could you explain a little further what nature means to you on a deep level and how do you relate with it?

Some time ago, I started transcendental meditation. It helps me to connect to my own nature, my body and my mind, but also to the universe around me. The very nature of things inspires me a lot, because we have a lot to learn from it. This is a concept that I keep within me and that I try to transmit through my projects, whether it is through the materials I use or through the timelessness of my work.

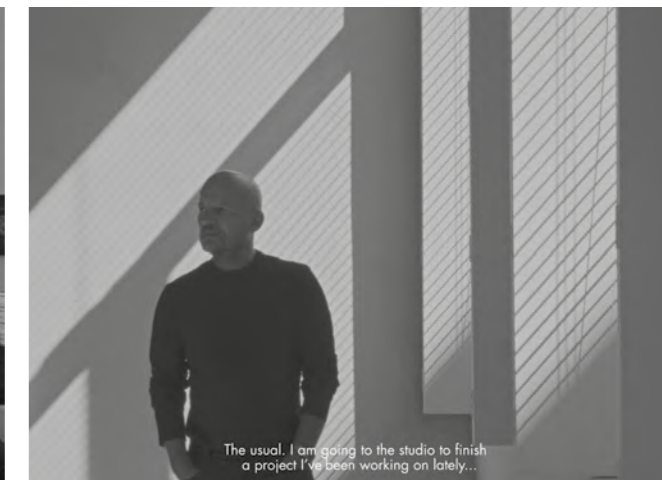

The usual. I am going to the studio to finish a project I've been working on lately...



For this collection, I wanted to delve into the history of patterns related to the world of architecture.

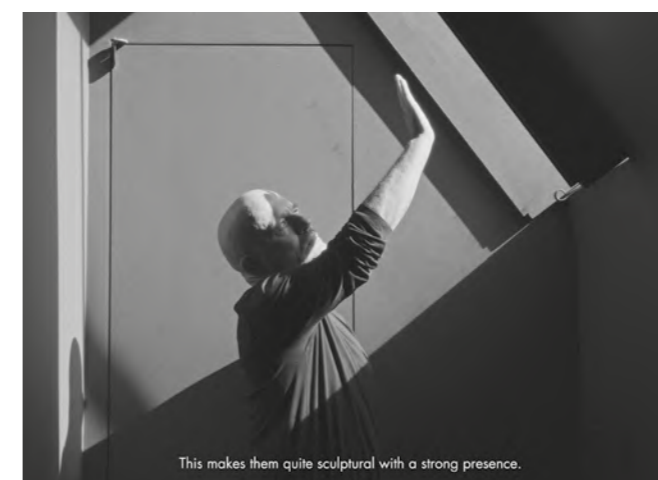

This makes them quite sculptural with a strong presence.

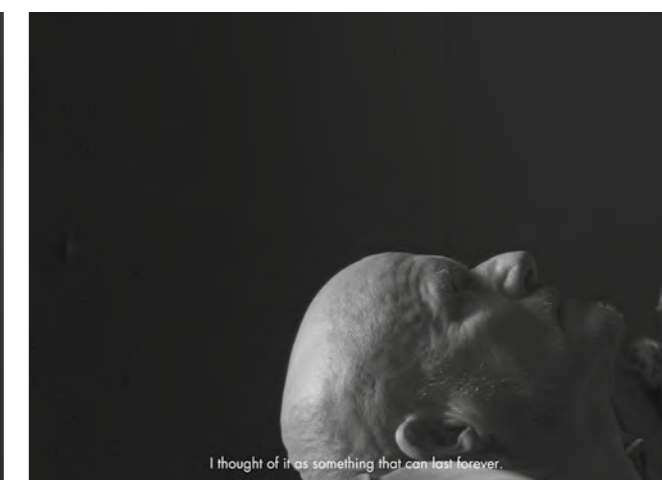

I thought of it as something that can last forever.

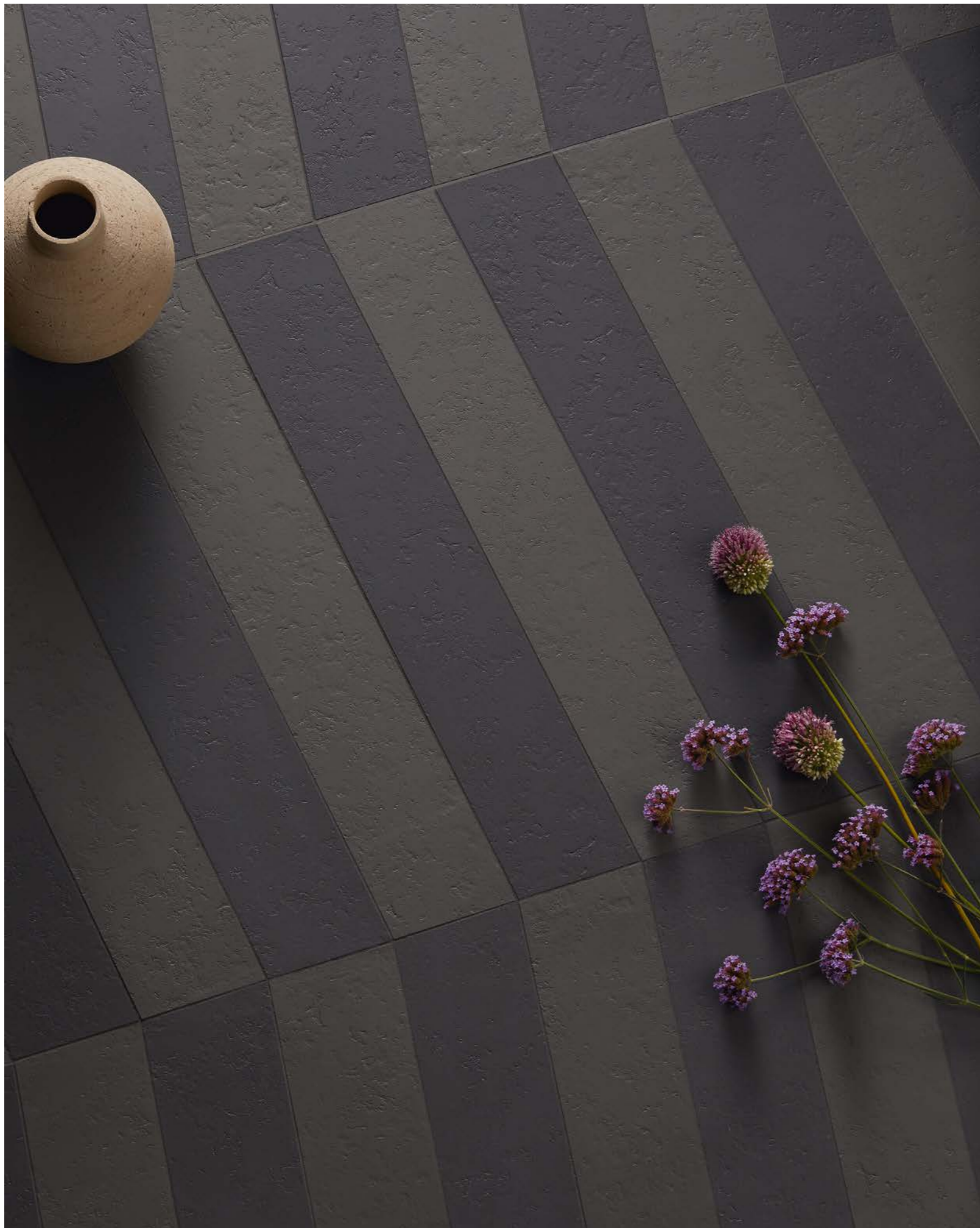

“Con Kosei volevo approfondire la storia dei pattern legati al mondo dell’architettura. Abbiamo ottenuto una collezione molto versatile, che ti permette di passare da un layout omogeneo a uno molto ritmato e grafico”.

“With Kosei, I wanted to go deeper into the history of patterns linked to the world of architecture. We have obtained an extremely versatile collection, with which it’s possible to go from a homogeneous layout to a very rhythmic and graphic one.”

Vincent Van Duysen

Opposite page – Kosei Dark Grey, Grey Green

Opposite page – Kosei Storm
Kosei Dark Grey, Storm, Terra, Grey Green

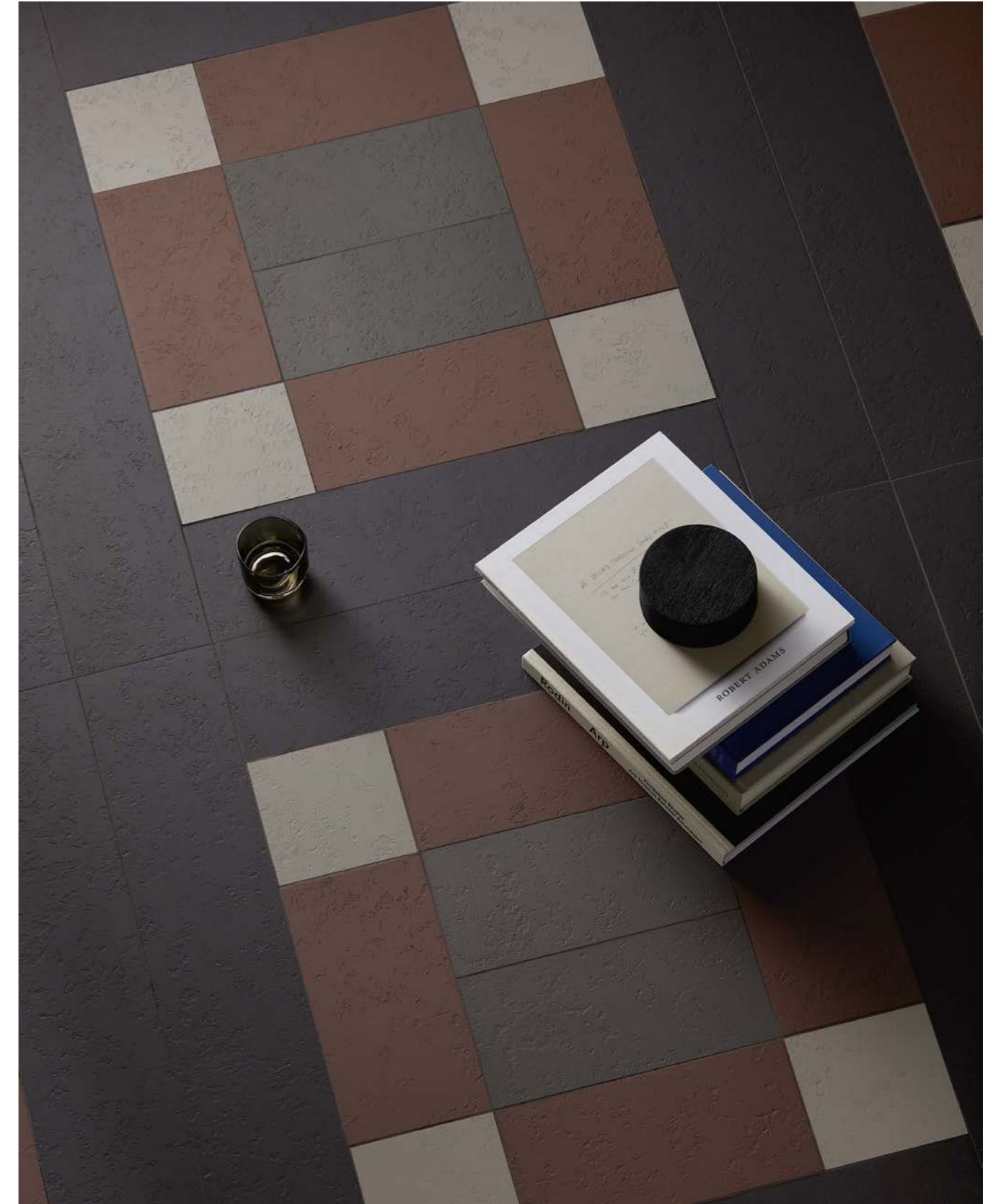



Lane

Edward Barber & Jay Osgerby

Lane è il risultato di un'analisi concettuale sul colore, interpretato attraverso uno studio dettagliato dei quartieri e delle architetture di Londra, città che da sempre è fonte di ispirazione per i designer. Lane si compone di tre versioni: Base, Poly e Mono. La versione Base consiste in cinque palette cromatiche (White, Black, Grey, Aubergine e Terracotta) ognuna delle quali è formata da un melange di numerosi toni diversi. Come nelle facciate degli edifici londinesi alcuni colori forti si stagliano sul tono di fondo, così in Poly vengono aggiunti alcuni elementi in contrasto ai range precedenti. Mono, invece, è la versione optical ed esiste solo nelle tonalità White e Black. La collezione è disponibile nel formato 7,9 x 16 cm ed è adatta ad ambienti interni ed esterni, sia a pavimento che a rivestimento.

Lane is the result of a conceptual analysis of colour, interpreted through a detailed study of the neighbourhoods and architecture of London, a city that has always been a source of inspiration for designers. Lane is composed of three styles: Base, Poly and Mono. The Base version comprises five colour palettes (White, Black, Grey, Aubergine and Terracotta), each of which is formed by a mix of different tones. Like facades in London, where a number of strong colours stand out against the background shade, added to Poly are a number of elements in contrast to the previous ranges, while Mono is the optical version and comes in White and Black only. The collection comes in the 7,9 x 16 cm size and is suitable for both indoor and outdoor settings, on both floors and walls.

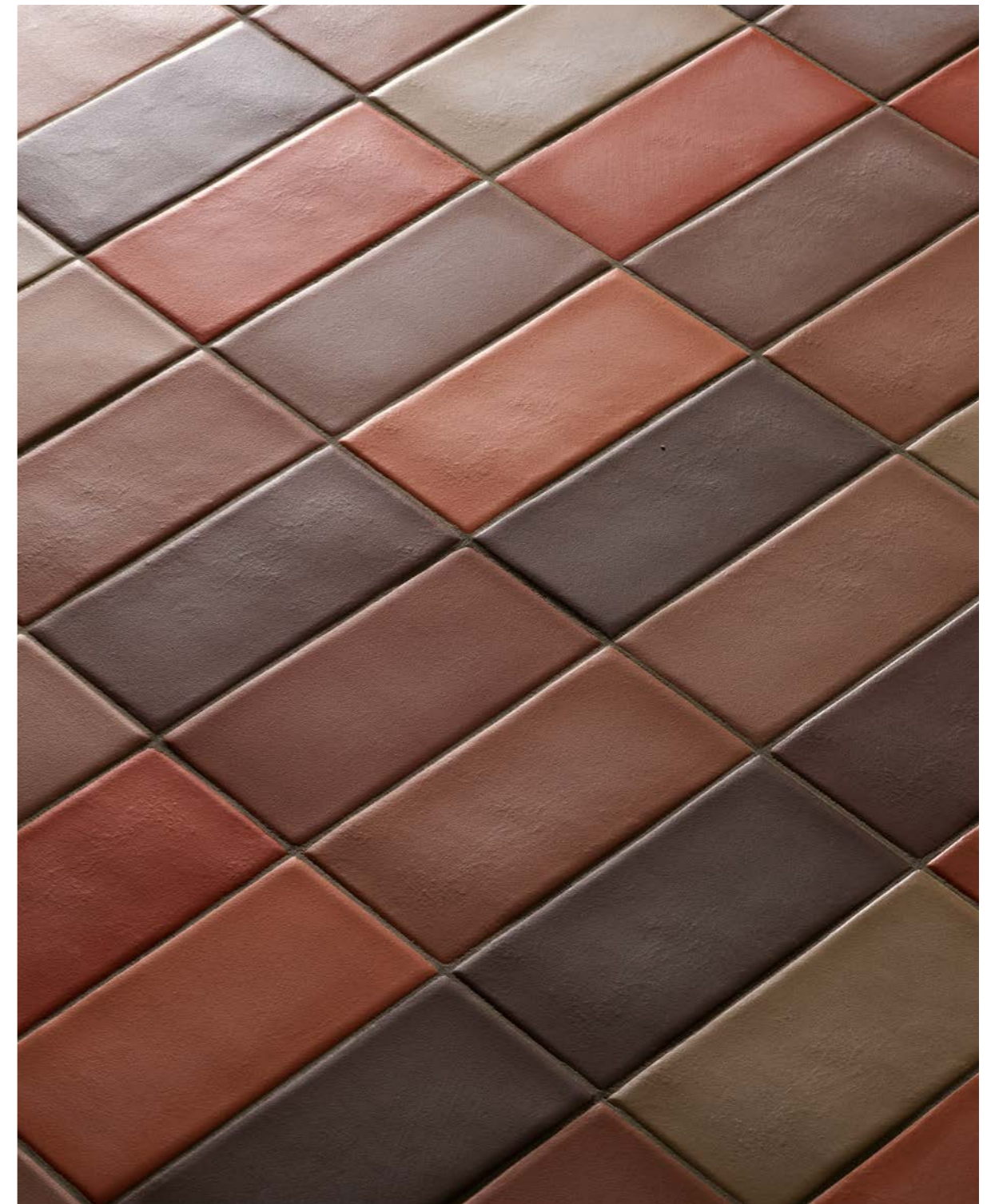

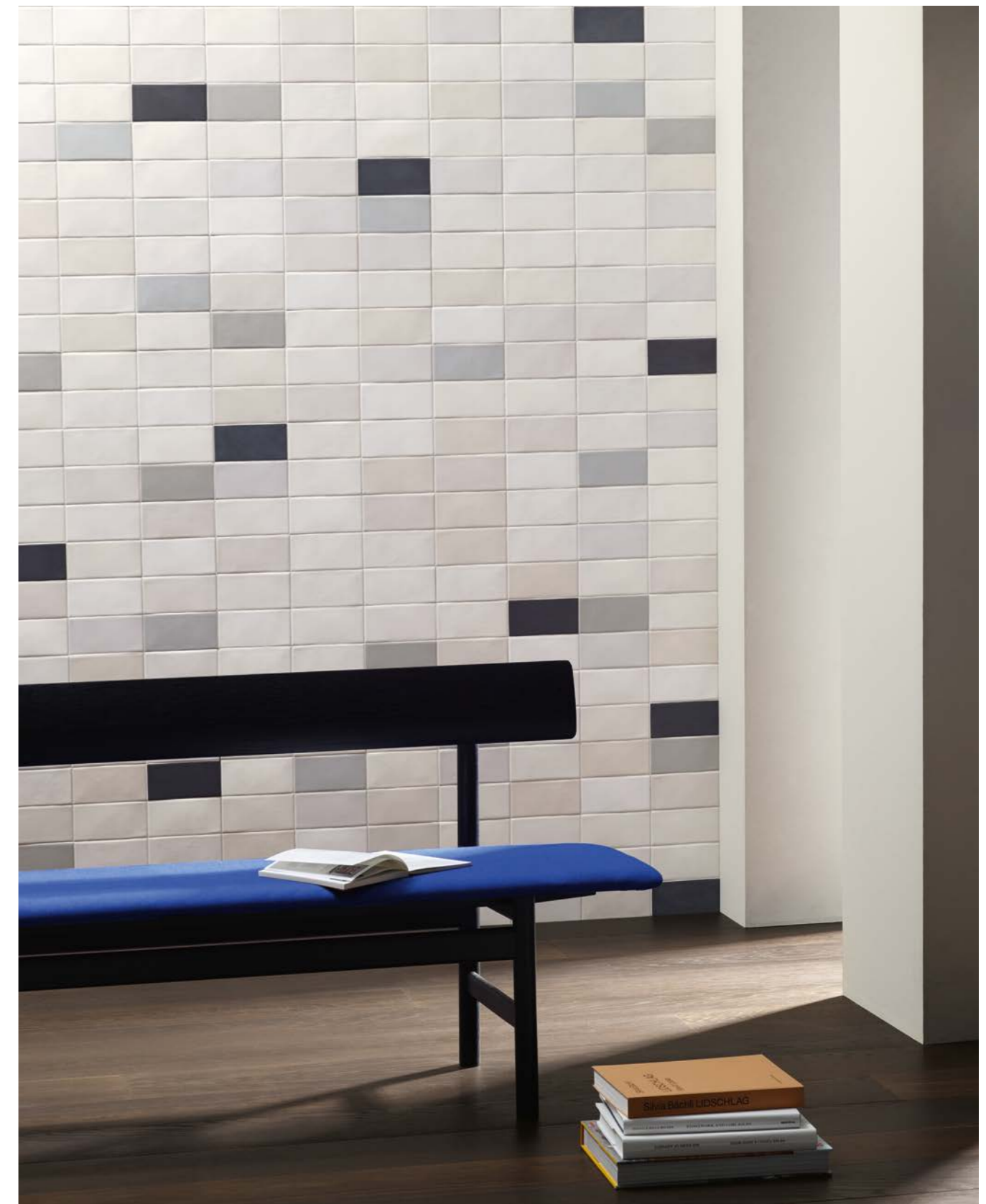

“Lane è un’evoluzione di Mews. Questa volta abbiamo cercato di accentuare la differenza sia nel colore che nell’intensità, così da rendere la collezione più vivace ed energica, dandole un aspetto giocoso”.

“Lane is a natural evolution from Mews. This time we have gone further by exaggerating the difference in both colour and tone to make a louder and more spirited collection, with a playful attitude.”

Edward Barber & Jay Osgerby

Opposite page – Lane Poly Aubergine, Base Aubergine
Next page – Lane Base Terracotta

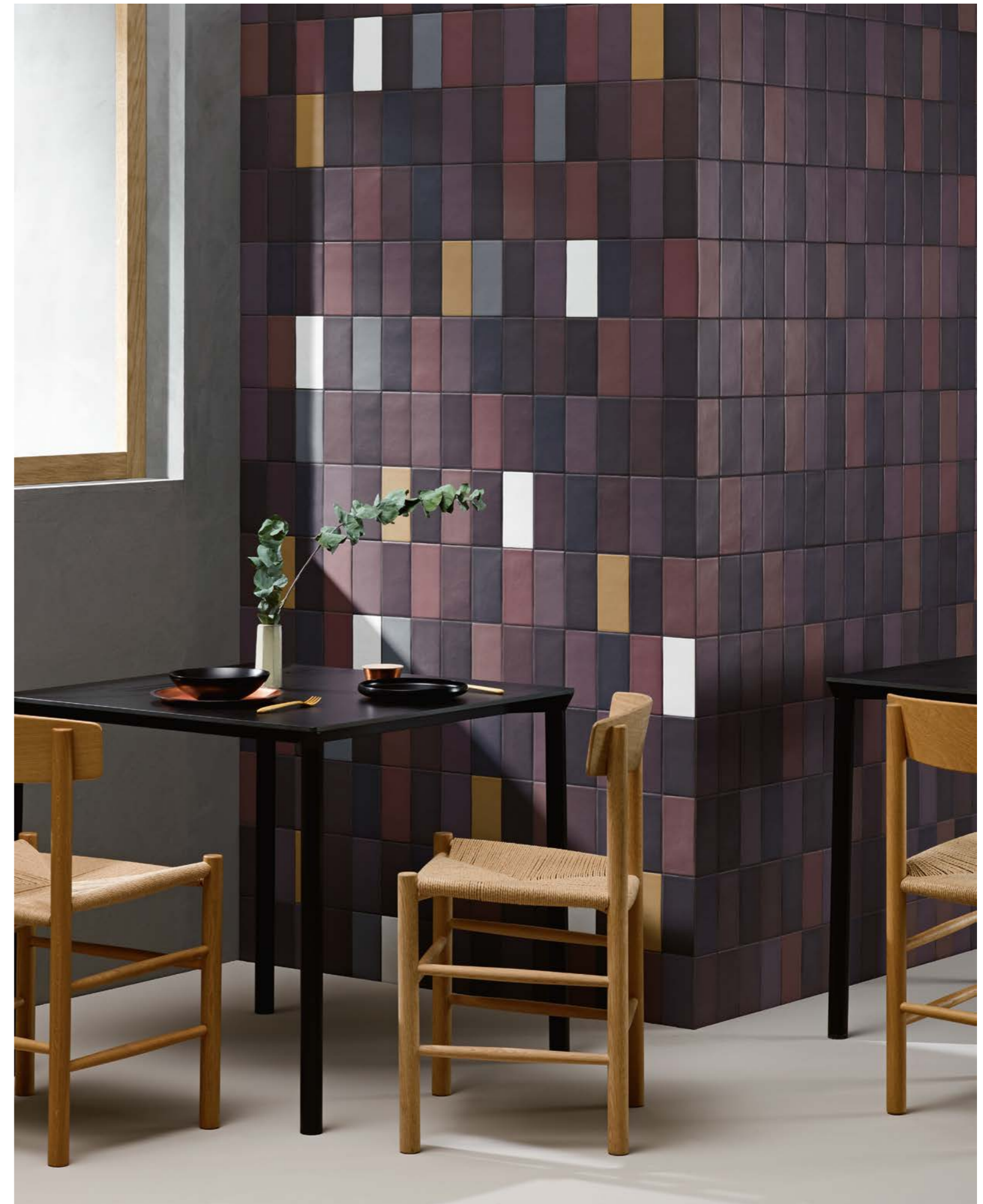



Mattonelle Margherita

Nathalie Du Pasquier

Con Mattonelle Margherita, Mutina lavora sul colore insieme all'artista Nathalie Du Pasquier, dando vita a un progetto articolato dove si intrecciano diversi linguaggi estetici e formali. La collezione è caratterizzata da un'anima duplice: da un lato semplice e minimalista, dall'altro creativa e coraggiosa. Il mondo di Mattonelle Margherita è composto da 41 diversi pattern disegnati a mano: 27 grafiche e 6 elementi in tinta unita nel formato 20,5x20,5 cm, 6 pattern e 2 elementi in tinta unita nel formato 10,1x20,5 cm. Le grafiche possono essere combinate tra loro, permettendo la creazione di infiniti layout, sempre diversi, innovativi e mai scontati, adatti a ricoprire intere superfici sia a pavimento che a rivestimento, o a creare interessanti accenti decorativi all'interno di qualsiasi tipo di abitazione, come boiserie, zoccoli e portali. A completare la collezione, il range di pitture Margherita Paints che propone 5 colorazioni, disponibili nelle versioni Matt e Satin (Rosa, Azzurro, Arancione, Giallo e Verde).

With Mattonelle Margherita, Mutina has worked with colour, along with the artist Nathalie Du Pasquier, creating a complex project featuring a blend of different aesthetic and formal means of expression. The collection is characterised by a dual concept: on the one hand, a simple, minimalist style and, on the other, a courageous, creative approach. The Mattonelle Margherita universe is composed of 41 different patterns, designed by hand: 27 graphics and 6 plain elements in the 20,5x20,5 cm size, 6 patterns and 2 plain elements in the 10,1x20,5 cm size. The graphics can be combined with each other, allowing for the creation of endless different layouts, always novel and innovative, suitable for tiling entire surfaces on both floors and walls, or for creative interesting decorative details in any home, such as wood panelling effects, skirting and door frames. To complete the collection, the range of Margherita Paints offers 5 colors, available in the Matt and Satin versions (Rosa, Azzurro, Arancione, Giallo e Verde).

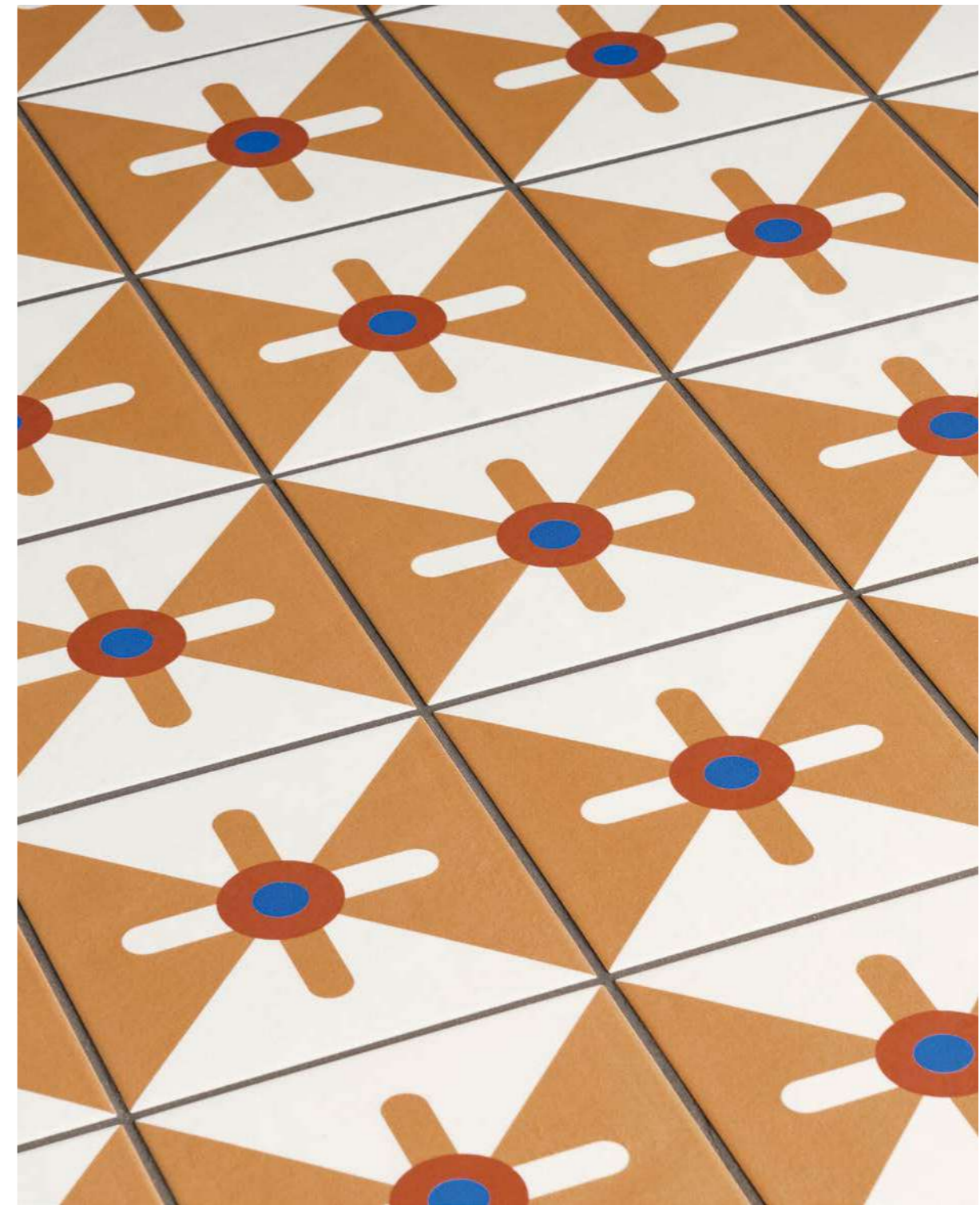

Mattonelle Margherita Marghe Green, Cones,
Marghe Half White, Spring Pink



Wall: Mattonelle Margherita Marghe Half White, Marghe Blue,
Double Blue, Margherita Paint: Rosa. Floor: Marghe Blue.



Wall: Mattonelle Margherita Marghe White, Frame Black, Marghe Half White, Marghe Half Black, Line.
Floor: Mattonelle Margherita Petals, Line.
Accents Paint: Sand Matt.





And since it's a ceramic company, I've always loved ceramics
and I've always done all sorts of things with bricks.



And that's the great thing about Mutina:
in an hour, Massimo already called someone who had gone to get some samples.

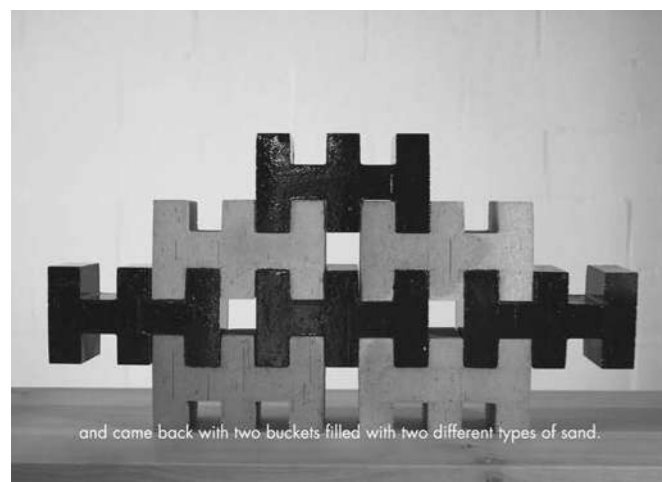

and came back with two buckets filled with two different types of sand.



A beautiful relationship was born and then, of course,
we decided to ask Nathalie to design a collection.



The combinations I'd come up with were also interesting...

La collaborazione con Mutina è iniziata con BRIC, l'installazione site-specific realizzata per lo spazio MUT nel 2019. Come è nato il progetto?

Massimo e Sarah Cosulich mi avevano contattata per realizzare un progetto nell'ambito di Mutina for Art. Non era necessario che fosse legato alla ceramica, ma ho sempre amato questo materiale e avevo fatto tante cose con i mattoni, quindi decisi di realizzare qualcosa con questi elementi. Inizialmente avevamo disegnato cinque elementi ad hoc, ma la produzione era troppo complicata, quindi decidemmo di tirare fuori i cataloghi di mattoni industriali ed è stato meraviglioso. Li abbiamo smaltati e combinati fra loro per creare delle architetture. La mostra era piaciuta tanto.

Dopo il successo di BRIC, è stato il momento di Mattonelle Margherita, con cui Mutina è tornata a lavorare sul colore. Come si è sviluppata la collezione?

Io ho un passato da designer, anche se molto remoto. Amo il decoro, mi piace molto la ceramica e adoro le piastrelle, quindi è avvenuto in modo molto spontaneo. In dieci giorni l'idea era pronta e, una volta prodotta, mi resi conto che era molto diversa dalle altre collezioni Mutina. Ho pensato che non era una collezione tanto da designer, era più popolare.

Come immagini gli elementi di Mattonelle Margherita all'interno di uno spazio abitativo?

Credo che la bellezza di Mattonelle Margherita sia nel fatto che ha diversi gradi di sofisticazione e di applicazione. Il progetto è molto articolato e può assumere diversi codici estetici a seconda di come viene utilizzato. Si possono combinare diversi pattern, creando un accento molto decorativo e abbastanza particolare, ma anche realizzare superfici con un linguaggio assolutamente minimal.

Come è stato scelto il nome della collezione?

Io ho una portinaia incredibilmente simpatica che si chiama Margherita, quindi ho pensato di chiamarla così. È un nome bello, perché fa pensare comunque al fiore, ed è un nome popolare. A me piace molto. Penso che funzioni proprio per la semplicità e la versatilità di questo tipo di decori.

The collaboration with Mutina begun with BRIC, the site-specific installation realised for MUT in 2019. How did the project came about?

Massimo and Sarah Cosulich contacted me to realise a project related to Mutina for Art. They weren't necessarily looking to do something with ceramics, but since I've always loved the material and I've done all sorts of things with bricks, I thought I'd enjoy building something with those elements. At first, we designed five special elements, but the production was tremendously complicated, so we decided to use industrial brick catalogues, and it all went marvelously from then onwards. We glazed them and combined with each other to create those architectures. The exhibition appealed so much.

After the success of BRIC, you started working on Mattonelle Margherita, with which Mutina got back to work on colour. How did the collection develop?

I used to work as a designer, although it was a long time ago. I love decorating, I love ceramics, and I'm a huge fan of tiles, so it happened in a very natural way. The idea was ready in ten days and, once it was done, I realised it was very different from the other Mutina collections. I thought it wasn't so much a designer collection, it was more of a popular style.

How do you imagine the elements of Mattonelle Margherita to interact into a residential space?

I think the great thing about Mattonelle Margherita is the fact it has different degrees of sophistication and application. The project is very articulated and can feature different aesthetic codes depending on how it is used. You can combine different pattern, creating a highly decorative, quite original detail, as well as surfaces with an absolutely minimal language.

Where did the name of the collection come from?

I have an incredibly nice concierge called Margherita, so I chose that name. It's a beautiful name, because it makes people think of the flower and it's a popular name. I like it a lot. I think it works precisely because of the simplicity and the versatility of this type of decorations.

“Mattonelle Margherita va bene per tutti. Mattonelle Margherita richiede fantasia. Mattonelle Margherita è per quelli che non hanno paura”.

“Mattonelle Margherita is meant for everyone. Mattonelle Margherita requires creativity. Mattonelle Margherita is meant for the fearless ones.”

Nathalie Du Pasquier

Opposite page – Wall: Mattonelle Margherita
Marghe Light Blue, Point, Wires, Street.
Floor: Mattonelle Margherita Marghe Light Blue.

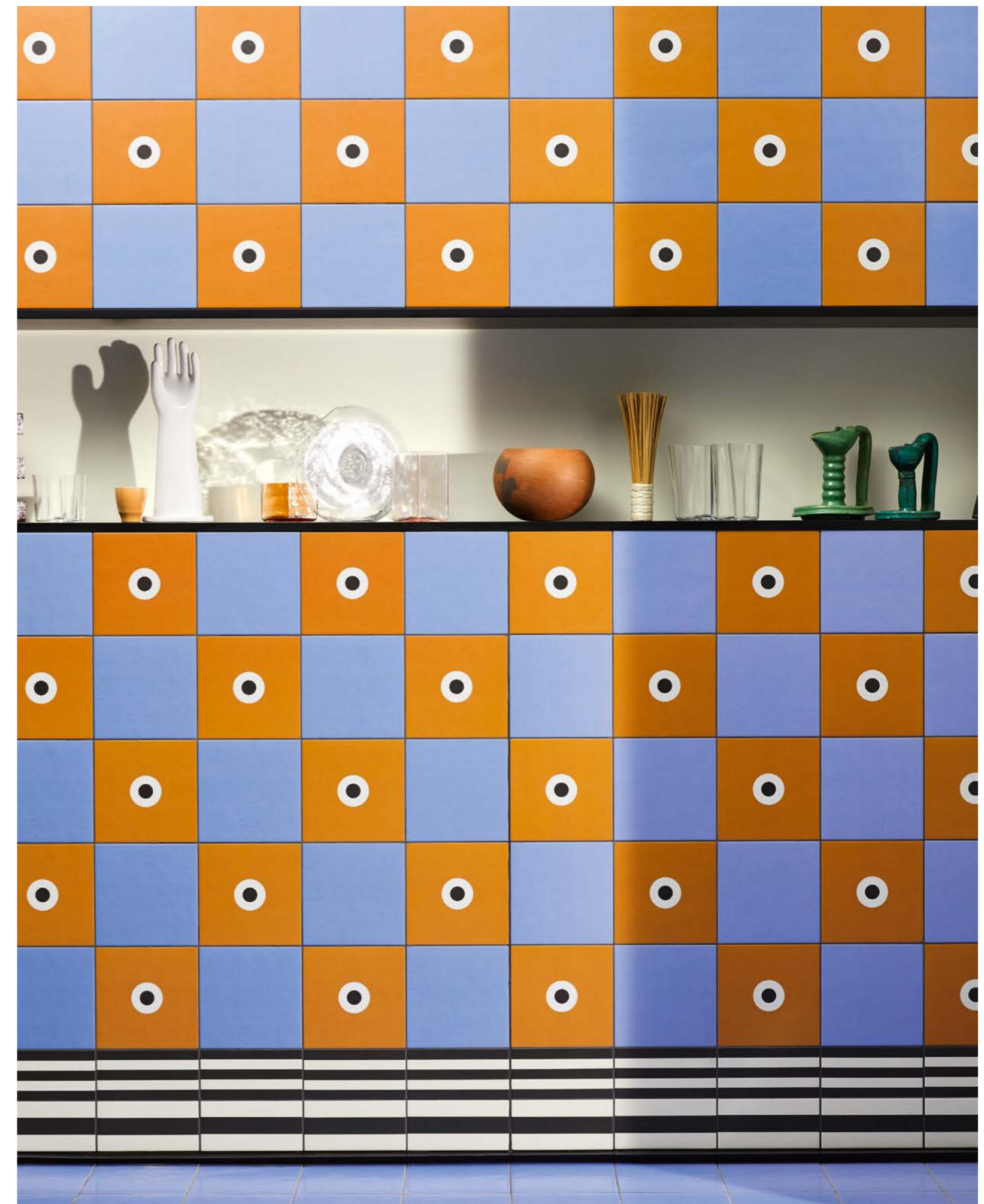



Opposite page – Mattonelle Margherita Square Black

Mattonelle Margherita Marghe Blue, Square Blue,
Rhombus White, Double Blue

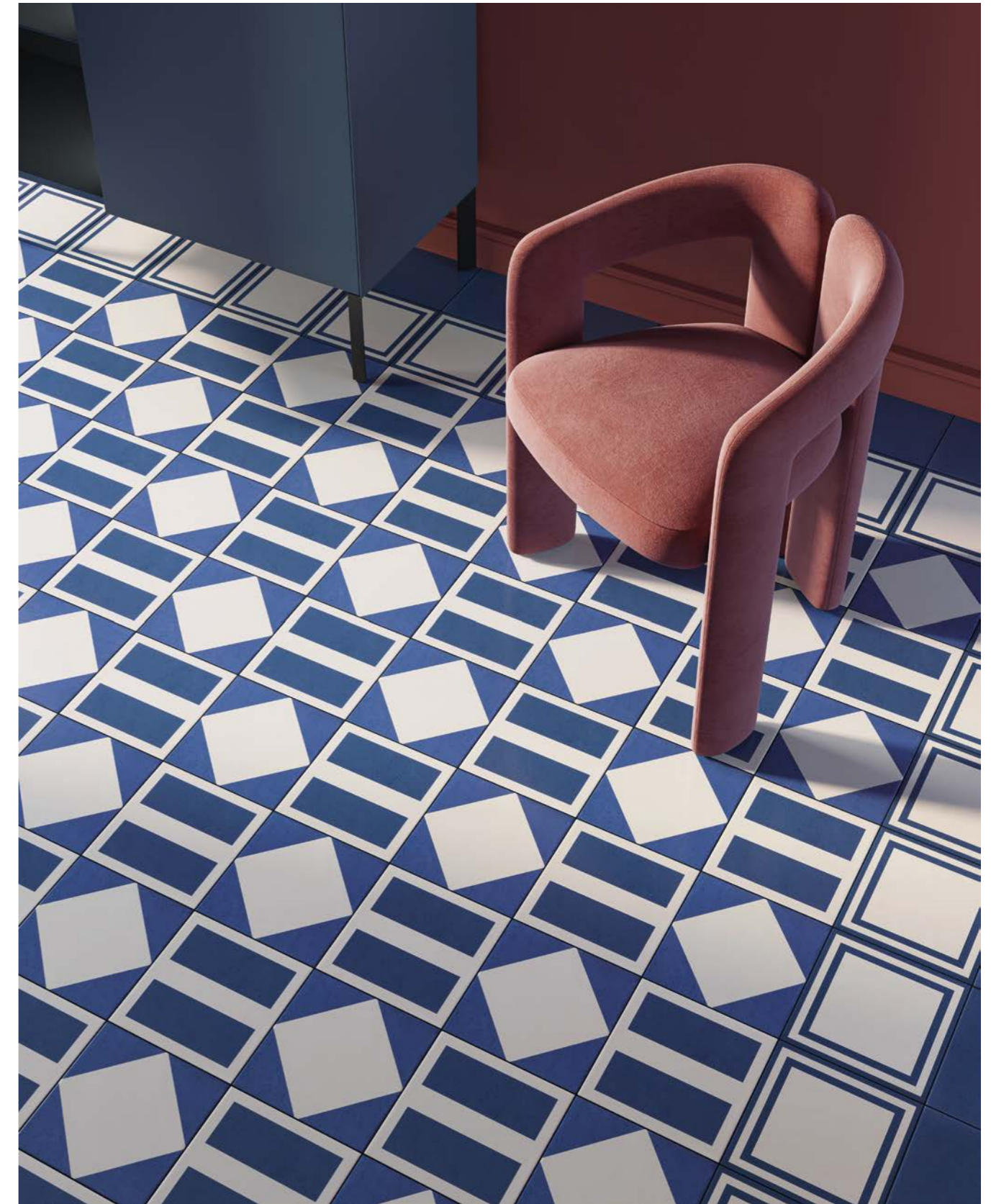

Mews

Edward Barber & Jay Osgerby

Mews trae ispirazione dal paesaggio, la storia e la personalità di Londra, così come dalla grande varietà di texture che caratterizzano le sue infrastrutture. Particolari che qui si fondono, andando a creare composizioni piacevolmente vibranti, dall'aspetto solo apparentemente casuale. Mews è il risultato di una lunga sperimentazione sul colore, che ha portato alla nascita di una palette di sei tinte base – Chalk, Fog, Pigeon, Lead, Ink e Soot – ognuna delle quali si suddivide nuovamente in 15 toni diversi, che conferiscono alla superficie posata un senso di profondità e movimento. La collezione è realizzata in grès porcellanato smaltato ad impasto colorato in massa secondo un processo industriale. L'ampio range di sfumature neutre consente di utilizzare gli elementi di Mews sia come punto focale di un ambiente che come sfondo per interni di ogni tipo.

Mews is inspired by the landscape, history and personality of London, as well as by the great variety of textures that characterize its infrastructures. These details merge, creating pleasantly vibrant compositions, with a seemingly casual appearance. Mews is the result of a long experimentation on colour, which led to the creation of a palette of six basic shades – Chalk, Fog, Pigeon, Lead, Ink and Soot – each of which is subdivided again into 15 different tones, which give the surface a sense of depth and movement. The collection is made of glazed porcelain stoneware with mass-coloured mixture according to an industrial process. The wide range of neutral shades allows the use of Mews elements both as a focal point of a space and as a background for interiors of all kinds.

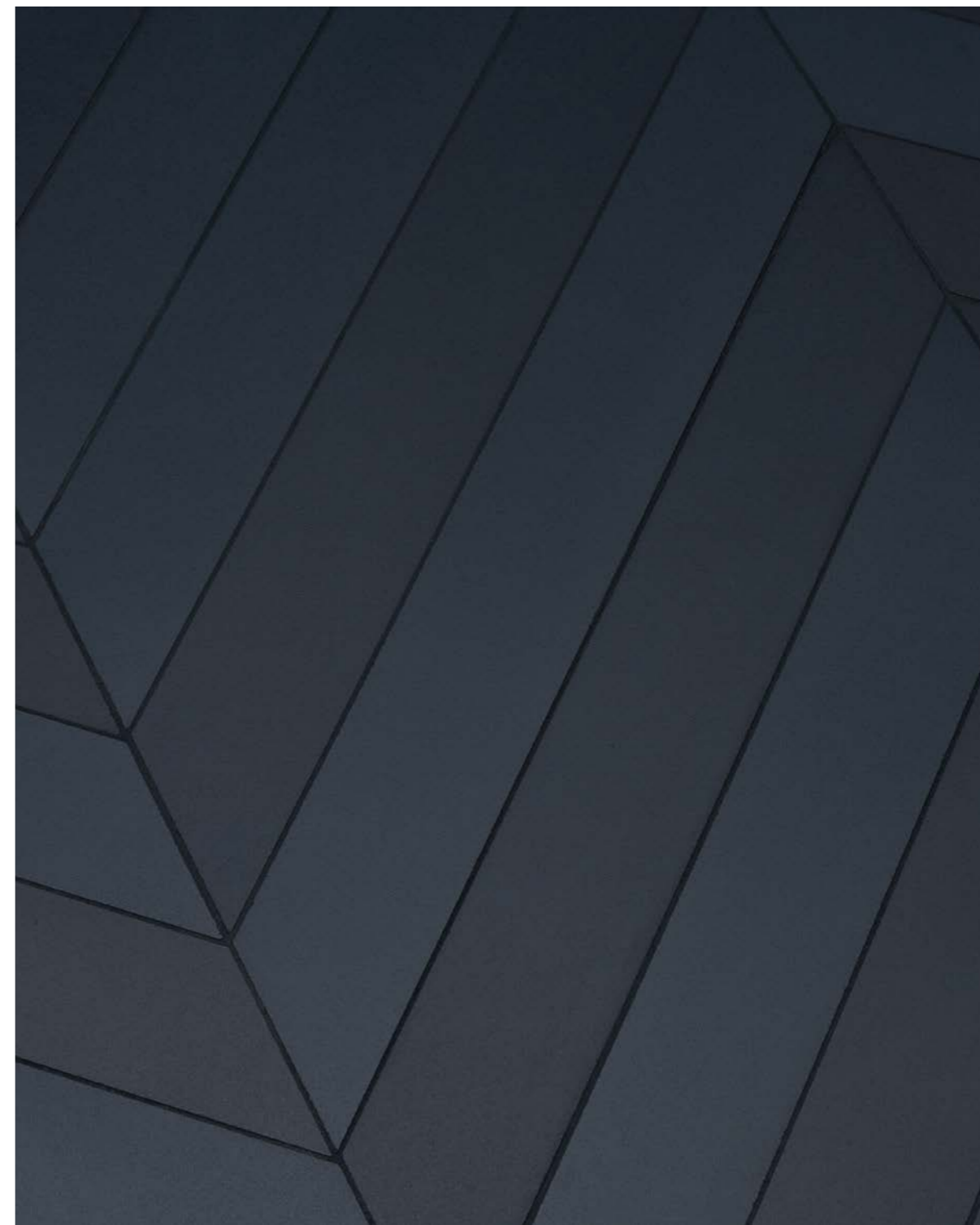

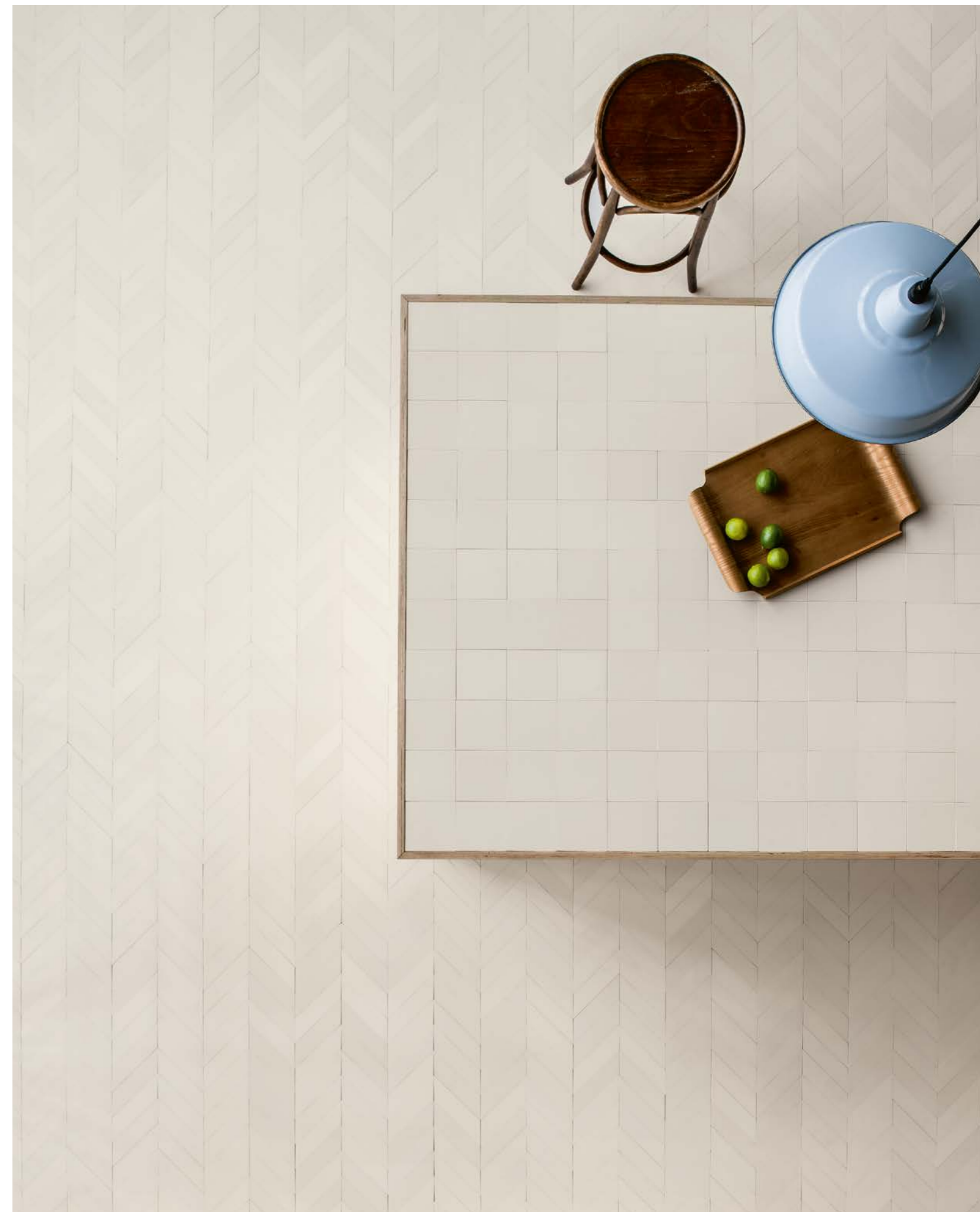





“Abbiamo puntato a catturare i toni naturali e le variazioni di luce e ombra presenti nel nostro ambiente, il paesaggio di Londra”.

“We aimed to capture the natural tones and variations in the light and shade that are present in our surroundings, the landscape of London.”

Edward Barber & Jay Osgerby

Previous page – Mews Lead, Soot
Opposite page – Mews Soot



Phenomenon

Tokujin Yoshioka

Phenomenon nasce dalla volontà di incorporare i fenomeni naturali e le leggi della natura in un progetto di design contemporaneo, non per imitarne l'aspetto ma per evocarne l'emozione. Ricorda diverse espressioni di pattern naturali come il favo delle api, i cristalli di neve, i candelotti di ghiaccio, le cellule delle piante ed evoca memorie di scenari naturali e di esperienze individuali del mondo della natura. Con la nuova edizione di Phenomenon, il range si arricchisce con 3 nuovi colori – Blu, Rosa e Verde – che si aggiungono ai 4 colori storici – Bianco, Grigio, Fango e Nero –, ognuno dei quali viene declinato su tutti gli elementi disponibili: Honeycomb A, Honeycomb B, Rock, Air, Wind, Rain A, Rain B e Rain C. Alla gamma si aggiungono anche i nuovi Phenomenon Glossy: i formati Honeycomb B, Rock e Rain A sono stati scelti per sperimentare la finitura smaltata per la prima volta, declinata nei colori Bianco, Nero, Oro e Argento. Le dimensioni estremamente ridotte delle tessere hanno reso necessario implementare un nuovo processo produttivo, che accosta il lavoro industriale a quello artigianale con l'obiettivo di fare risaltare al massimo la finitura.

Phenomenon stems from the desire to incorporate natural phenomena and the laws of nature into a contemporary design project, not simply for reproducing their aspect but to evoke an emotion. The collection reminds of different expressions of natural patterns such as honeycombs, snowflakes, sticks of ice, plant cells, evoking memories of natural sceneries and individual experiences of the natural world. With the new edition of Phenomenon, the range is enriched with 3 new colours – Blu, Rosa and Verde – which join the 4 historical ones – Bianco, Grigio, Fango and Nero –, each of which is offered on all the available elements: Honeycomb A, Honeycomb B, Rock, Air, Wind, Rain A, Rain B e Rain C. The range also includes the new Phenomenon Glossy: the Honeycomb B, Rock and Rain A modules have been chosen to experiment the glossy finish for the first time, featuring the Bianco, Nero, Oro and Argento shades. The extremely small size of the tesserae has made it necessary to set up a new production process that combines industrial and craft approaches with the objective of making the finish stand out as much as possible.





Opposite page – Phenomenon Honeycomb A Blu
Phenomenon Rain B Verde



Come descriveresti il tuo approccio personale alla ceramica?

Utilizzo la ceramica come se fosse un riflesso della natura. Così come la luce, l'acqua e il suolo danno vita a fenomeni naturali.

Come si è sviluppato il progetto di Phenomenon?

Mutina mi aveva proposto di pensare a un nuovo mosaico. Negli anni ho realizzato diverse installazioni legate al tema della natura, quindi mi sono chiesto se fossi in grado di fare la stessa cosa con un progetto di questo tipo. Con Phenomenon abbiamo lavorato sull'idea di creare dei paesaggi utilizzando fenomeni naturali come la pioggia, il vento e la luce, che rappresentano il cuore della collezione.

Nel 2022 è stata lanciata una nuova edizione della collezione. Che tipo di lavoro è stato fatto sulla gamma di elementi già esistente?

Abbiamo sperimentato nuove forme di espressione, con l'obiettivo di dare a Phenomenon una bellezza nuova.

Quali vantaggi ha portato l'unione tra l'approccio industriale e quello artigianale?

Credo che combinando l'aspetto moderno dei prodotti industriali con il carattere caldo e ricco dell'artigianato, siamo riusciti a creare una fusione tra storia e futuro.

How would you describe your personal approach to ceramic?

I use ceramic as if it is a reflection of nature. Just like light, water, soil and plants create natural phenomena.

How did the project of Phenomenon develop?

Mutina asked me to try thinking of a new mosaic. Over the years, I have been doing installations focusing on the theme of nature, so I wondered if I could do such a thing with that kind of project as well. For Phenomenon, we have worked on the idea of creating landscapes with natural phenomena such as rain, wind and light, which is what the collection is all about.

A new edition of the collection has been launched in 2022. What kind of work has been done on the already existing elements?

In order to create a new beauty in the Phenomenon collection, we tried various new expressions.

What were the benefits of combining industrial and craft approaches?

I think that by combining the modern expression of technological industrial products with the warm and rich character of craftsmanship, a fusion between history and future emerges.



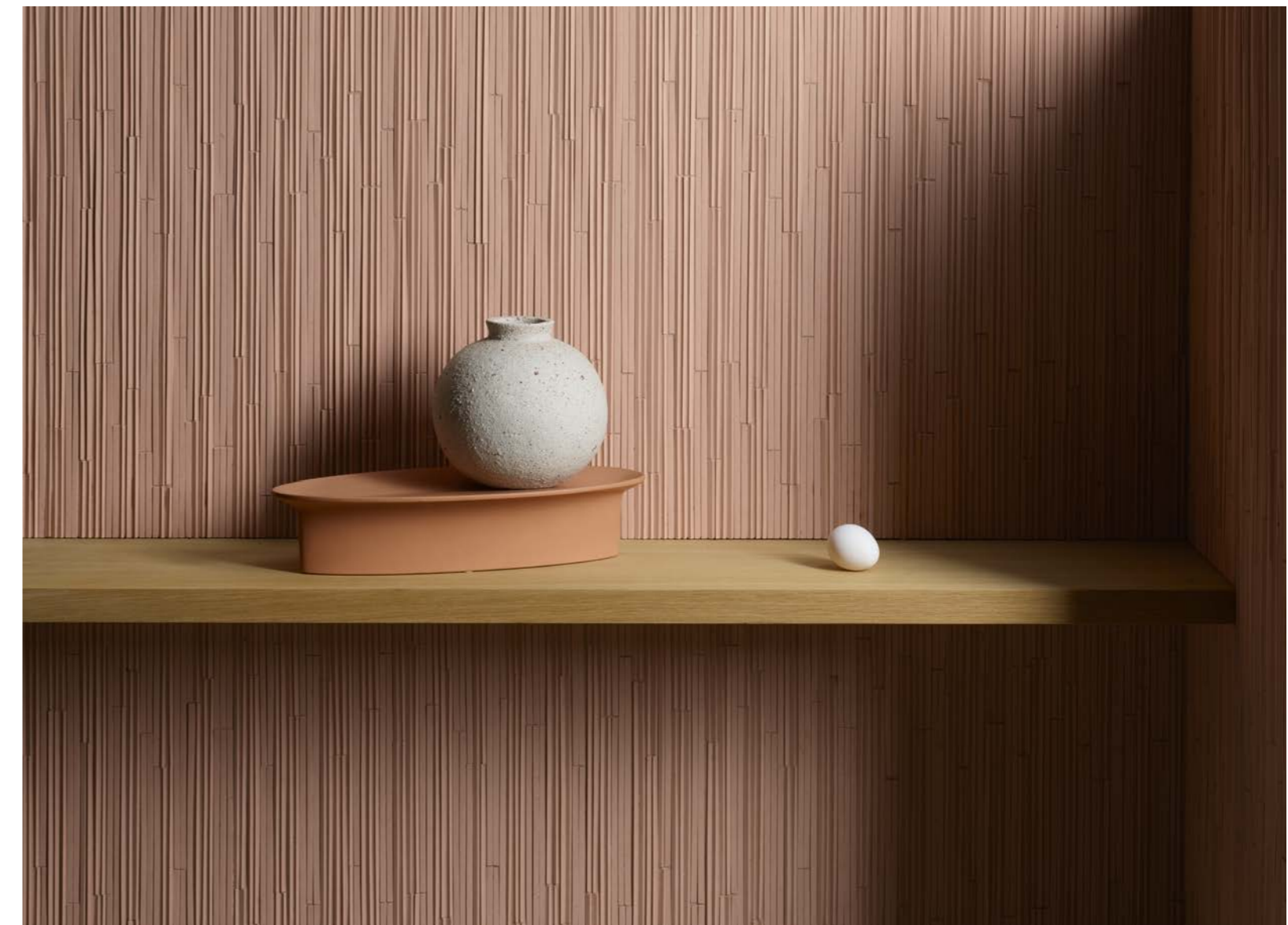



Pico

Ronan & Erwan Bouroullec

Nell'ideazione di Pico, lo sforzo è stato interamente volto alla definizione di un prodotto che unisse regolarità e irregolarità, giungendo così alla declinazione in due superfici: Down, con punti scavati, e Up, con punti a rilievo. Per rendere l'effetto ancora più vibrante, è stato deciso di utilizzare il rosso e il blu sotto forma di puntini su un fondo neutro o come colori di base. Con la nuova edizione di Pico, alle colorazioni Blanc e Gris si aggiungono Argile, realizzata con gli stessi materiali e la stessa tecnologia delle varianti già esistenti, e Pico Satin, ottenuta con l'ausilio della tecnologia CONTINUA e di uno smalto satinato atomizzato, che hanno permesso di ottenere una superficie morbida e piacevole al tatto, di un grado di bianco assoluto. In questo modo, grazie ai giochi cromatici e alla speciale miscela utilizzata, che conferisce al prodotto un sorprendente effetto di profondità e matericità, vanno a crearsi ombre delicate che mettono in risalto i rilievi e donano alle piastrelle una tonalità più fredda o più calda a seconda delle nuance prescelte. Prodotta nei formati 120x120 cm, 60x120 cm e 60x60 cm, Pico presenta preziose finiture naturali ed è adatta all'utilizzo sia in ambienti interni che esterni.

While developing Pico, we have worked on defining a regular-irregular texture, declined in two surfaces: Down, with sunken dots, and Up, with elevated dots. To add dynamics, we also decided to use colours such as red and blue, applied as little dots in the hollow or as a base. With the new edition of Pico, the colours Blanc and Gris are joined by Argile, realised with the same materials and technology of the already existing variants, and Pico Satin which is obtained by using CONTINUA technology and a satin atomised glaze, that allow to get surface of absolute whiteness, soft and pleasant to the touch. In this way, thanks to chromatic plays and the special mixture which give the product an incredible effect of depth and tactility, delicate shadows take shape and activate the relief, turning the tiles a nuance colder or warmer depending on the chosen colour. Available in 120x120 cm, 60x120 cm e 60x60 cm formats, Pico is characterised by natural and refined finishing, and can be used both indoors and outdoors.

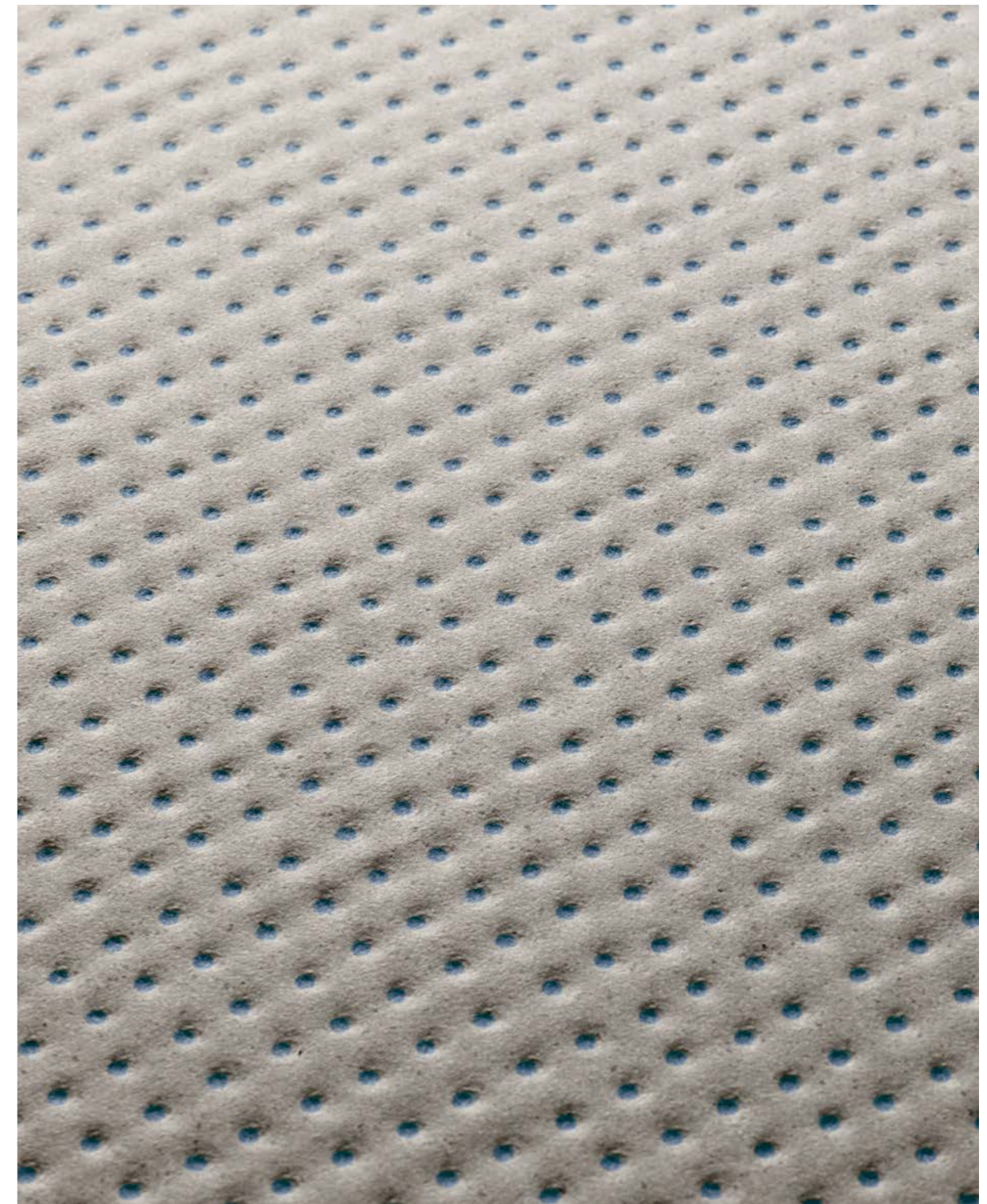

Wall: Pico Blue Dots Satin, Pico Up Blue. Floor: Pico Blue Dots Gris.
Opposite page –Pico Down Natural Blanc

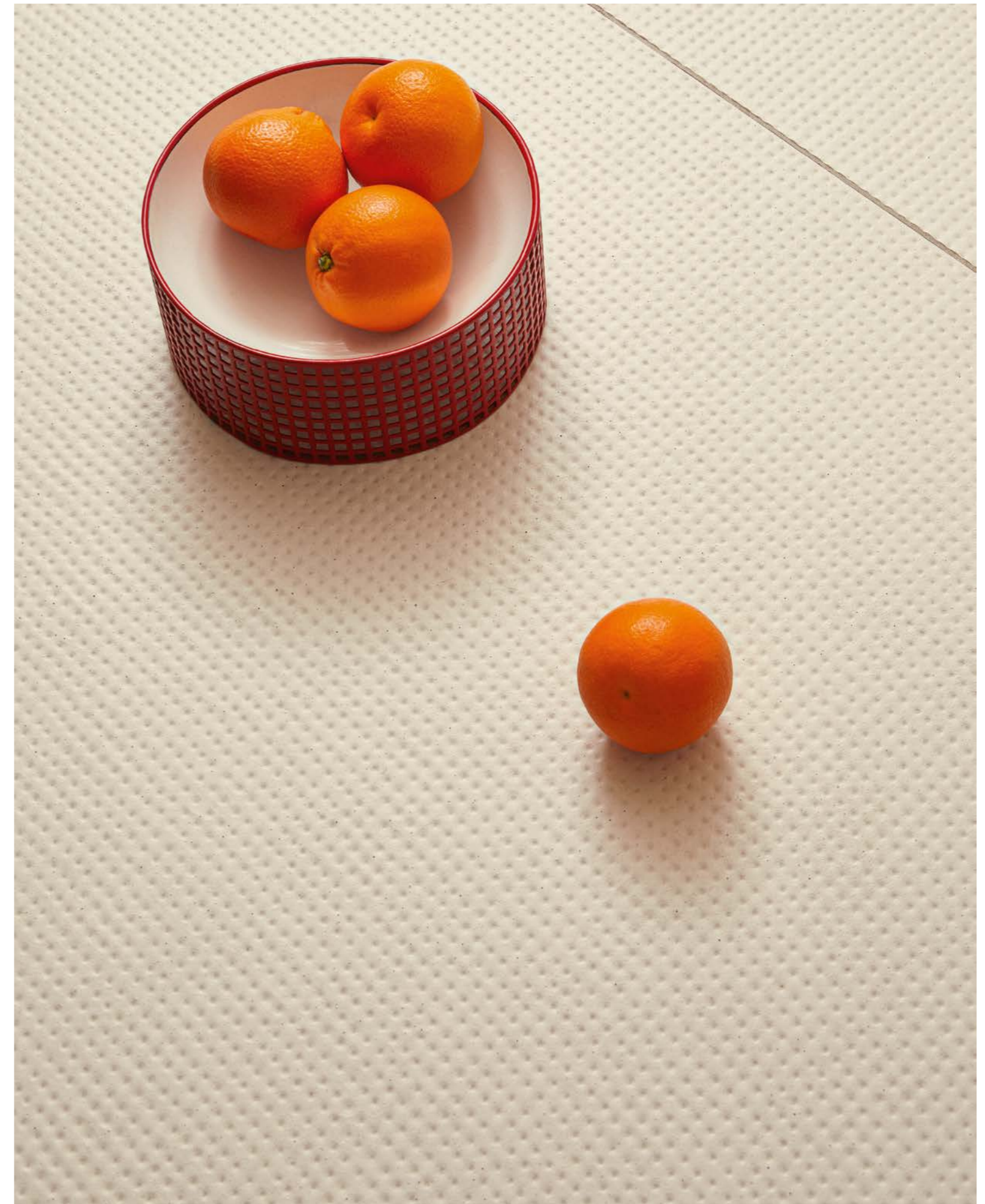
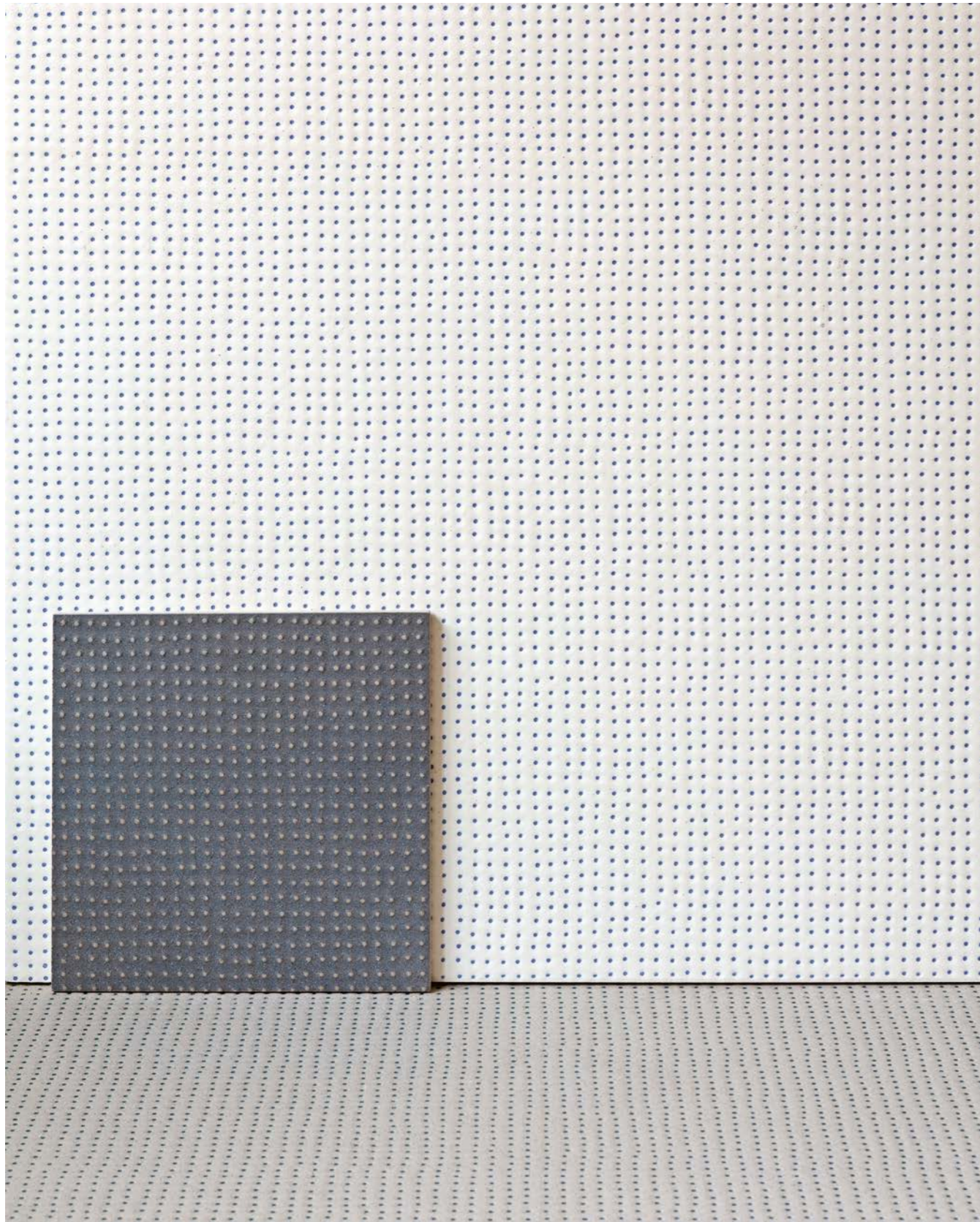



“Pico è notoriamente uno dei progetti di cui siamo maggiormente soddisfatti. Non è un sentimento che proviamo spesso, con tale spontaneità. Quando certi musei ci invitano a realizzare delle retrospettive, questa collezione occupa un posto preponderante nell’esposizione”.

“Pico is notoriously one of the most satisfying projects for us. We don’t often have such a spontaneous feeling. When museums invite us to create a retrospective exhibition, this collection always has a dominant position.”

Ronan & Erwan Bouroullec

Previous page – Wall: Pico Blue Dots Gris. Floor: Pico Down Natural Gris.
Opposite page – Pico Red Dots Gris



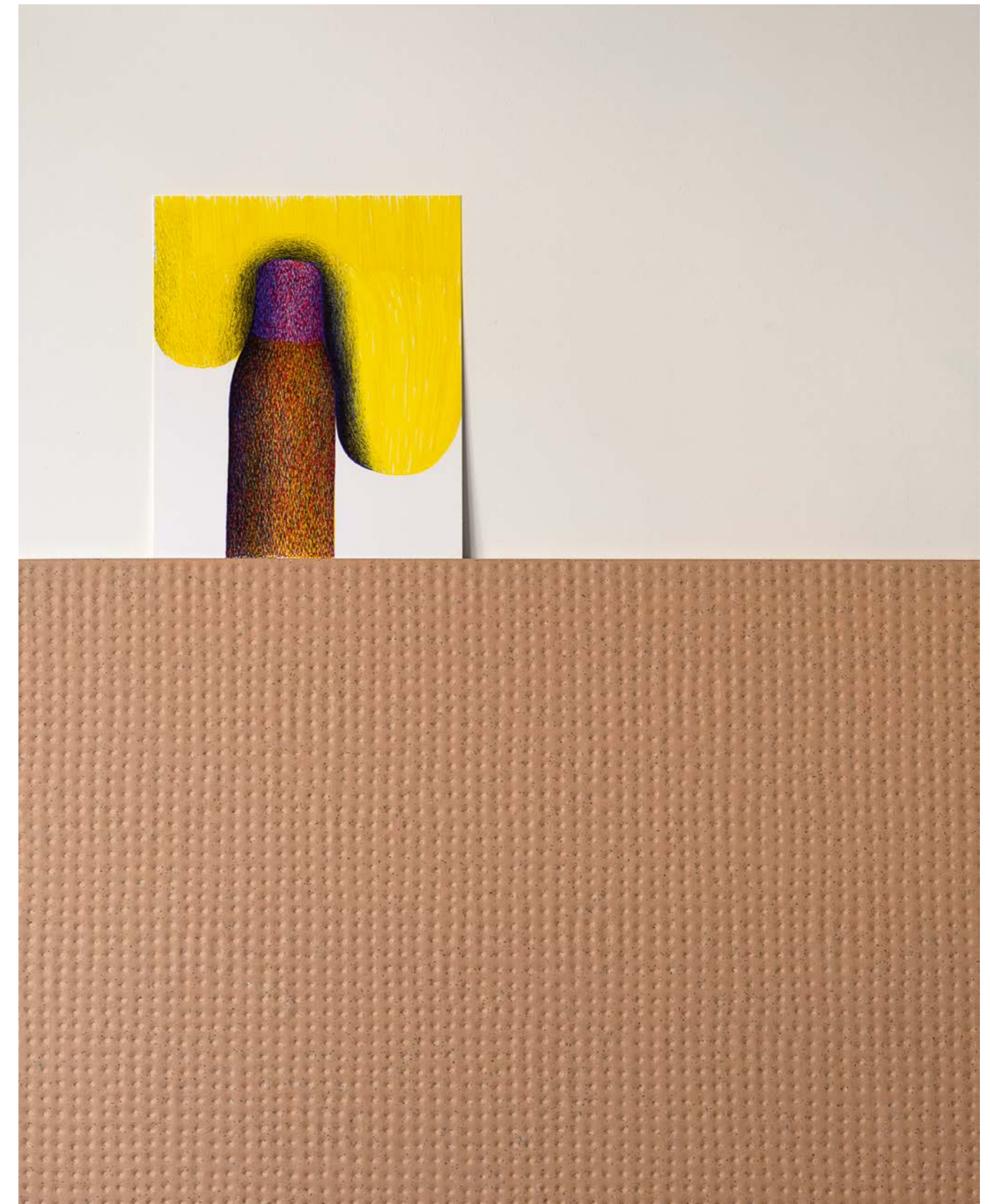



Primavera

Edward Barber & Jay Osgerby

Primavera è una rappresentazione del contrasto millenario tra l'elemento naturale e il mondo artificiale, in forma ceramica. Gettando piccole scaglie colorate in maniera del tutto randomica sulla superficie, i designer sono riusciti a ricreare l'illusione di un materiale naturale e delle sue irregolarità, dando così vita a una texture sempre unica e diversa. Prodotte in grès porcellanato non smaltato, le piastrelle sono disponibili nei formati 60x60 cm, 120x240 cm, 120x120 cm e 40x120 cm, in cinque colorazioni differenti: Bianco, Grigio, Verde, Blu e Nero. Accantonare un design lineare a favore di un risultato decorativo nella sua irregolarità conservando, tuttavia, il valore aggiunto della manifattura, ha dato vita a un prodotto contemporaneo e raffinato, adatto a una posa a pavimento e rivestimento, sia in interni che in esterni.

Primavera represents the contrast between the natural element and the artificial world, translated into ceramic. The designers have reproduced a slab that resembles a natural element with all its irregularities, by throwing small coloured ceramic inserts in a completely random way, thus creating a unique and always different texture. Produced in glazed porcelain stoneware, the tiles are available in size 60x60 cm, 120x240 cm, 120x120 cm and 40x120 cm and consist of five basic colours: Bianco, Grigio, Verde, Blu e Nero. To abandon a linear design in favour of a decorative yet irregular result, still preserving the added value of manufacture, gave birth to a contemporary and refined product that is suitable for both floors and walls, indoors and outdoors.



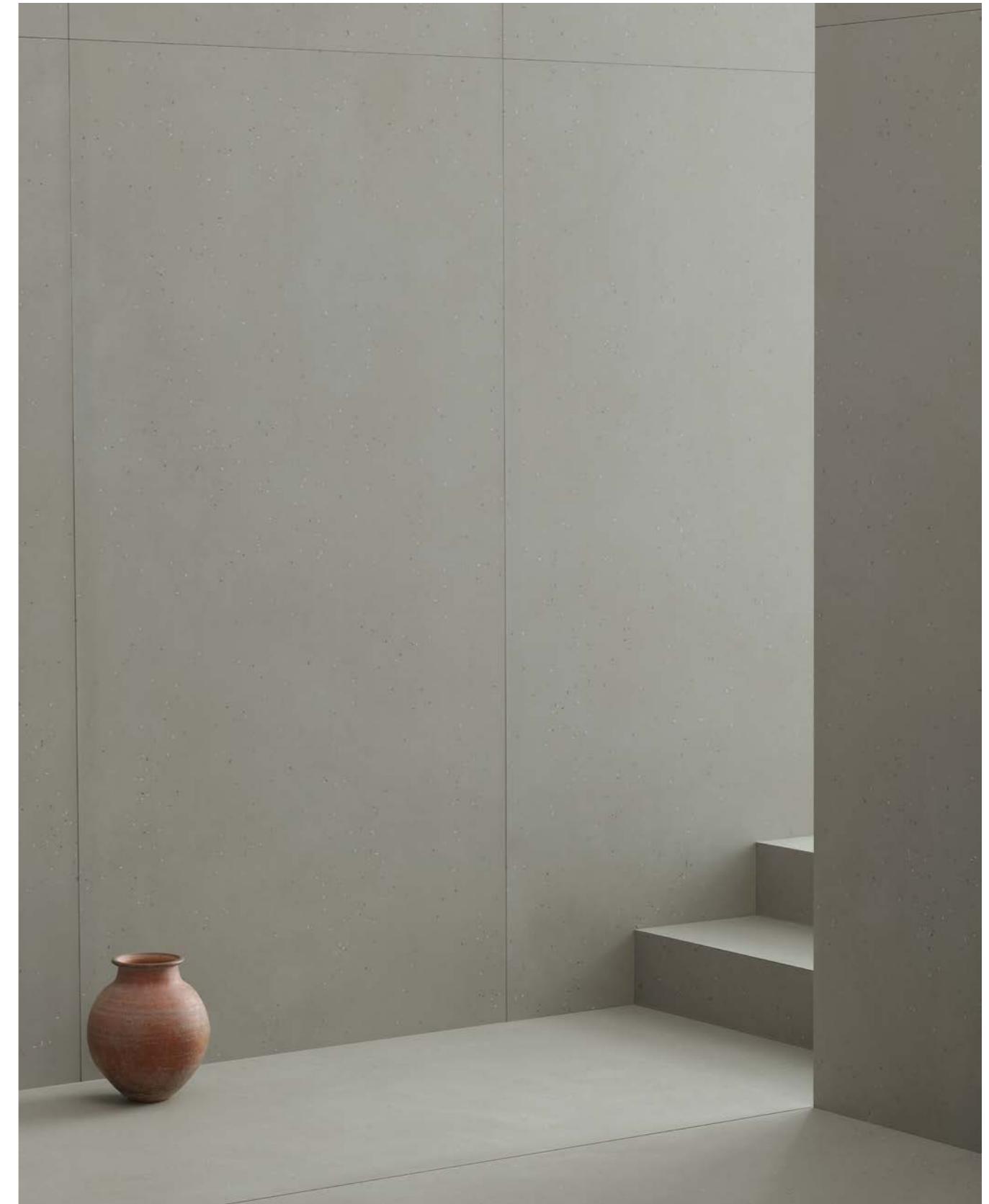



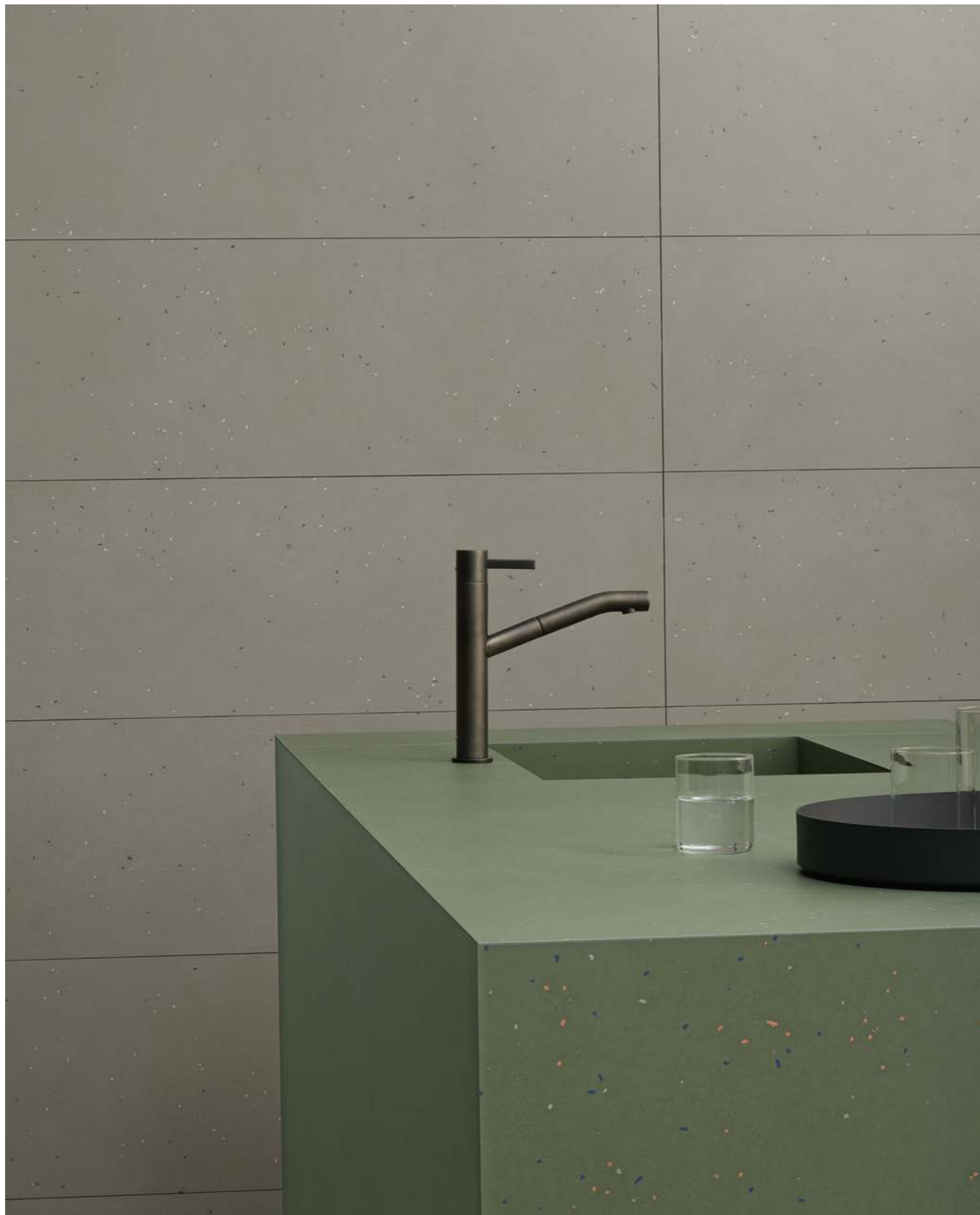

Previous page – Primavera Bianco
Wall: Primavera Grigio. Kitchen: Primavera Verde.



“Primavera rappresenta il contrasto tra la natura e il mondo artificiale. Abbiamo trovato il modo di sfruttare la manifattura per catturare l'autenticità di un materiale naturale, creando delle imperfezioni sulla superficie piuttosto che riproducendo un design”.

“Primavera is the contrast between nature and the artificial world. We found a way to capture the authenticity of a natural material by manufacturing imperfections on the surface rather than by reproducing a design.”

Edward Barber & Jay Osgerby

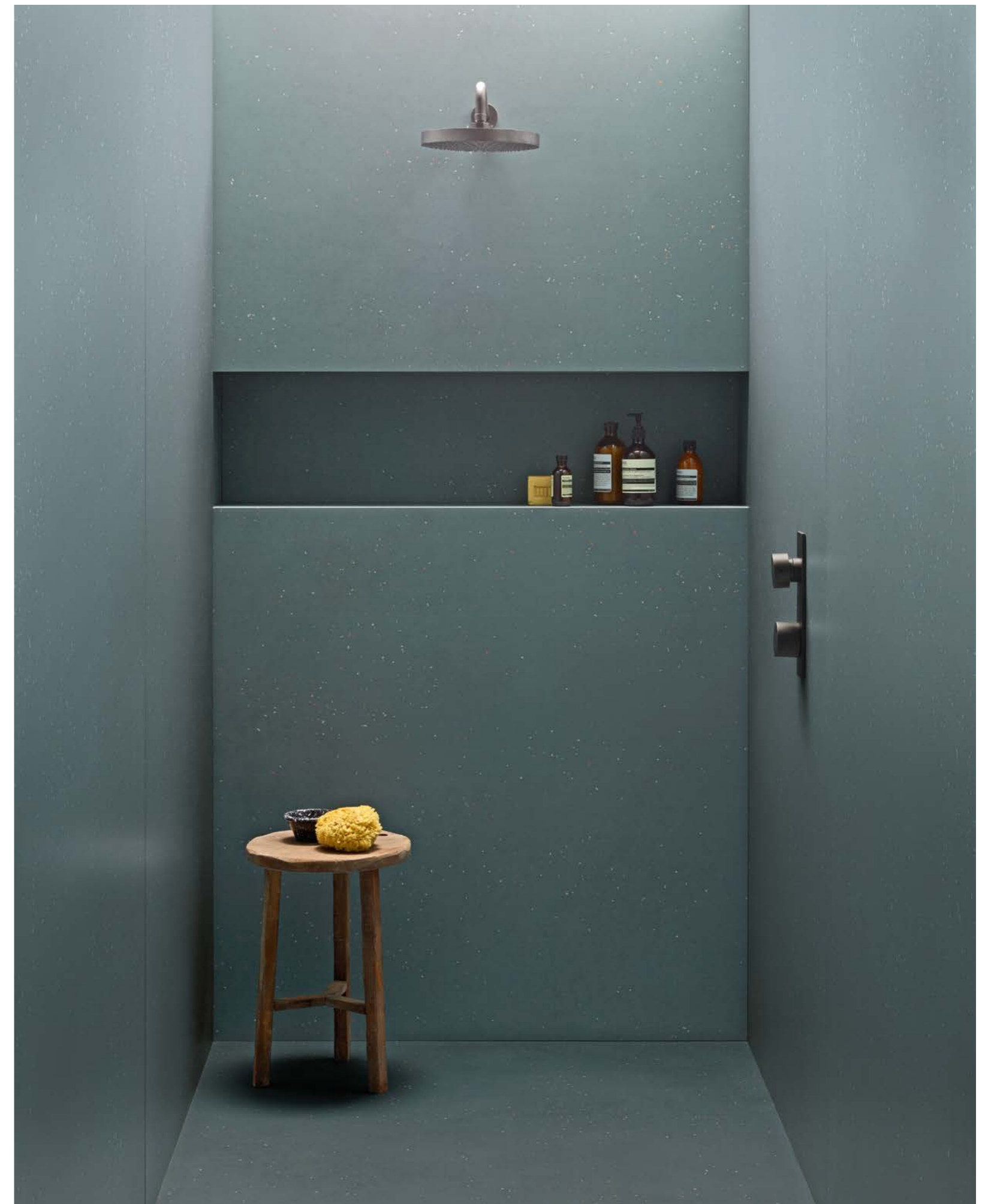



Primavera Nero, Grigio
Opposite page – Wall: Primavera Grigio. Floor: Primavera Nero.

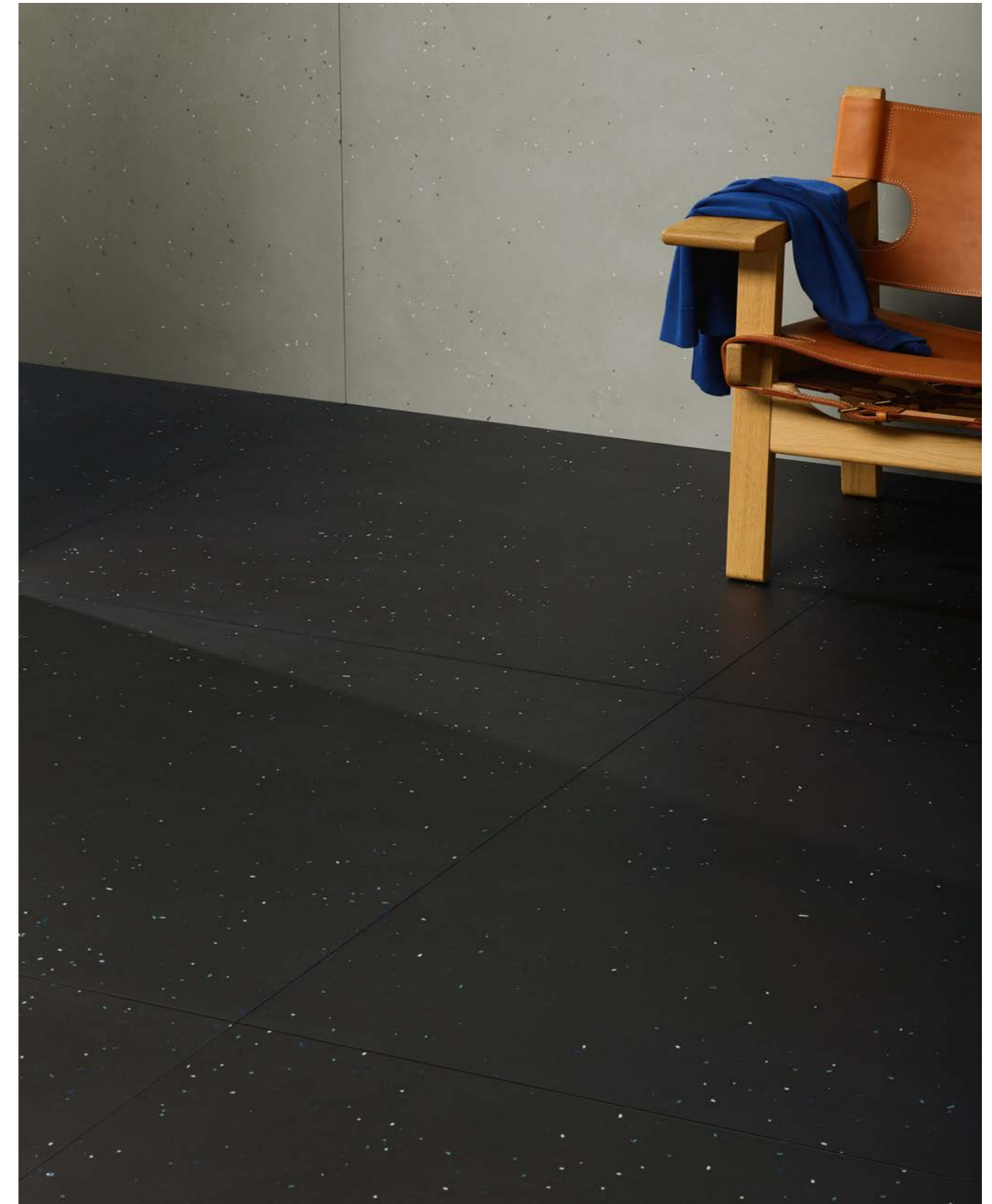

Punto

Ronan & Erwan Bouroullec

Evoluzione del concept che aveva ispirato la collezione Pico, Punto è un elemento decorativo tridimensionale, pensato specificamente per essere utilizzato a rivestimento. Il pattern, caratterizzato da grossi punti scavati (Down) o a rilievo (Up), trova la sua massima espressione utilizzato su superfici di grandi dimensioni. A seconda di come vengono colpiti dalla luce, gli elementi prendono vita attraverso inaspettati giochi chiaroscurali che ravvivano gli interni. Ognuna delle varianti Up e Down esiste nel formato singolo di 4x31.5 cm, fornito su reti di cinque pezzi ciascuna. La palette comprende cinque colorazioni con finitura Matt (White, Grey, Red, Green e Blue) e cinque con finitura Glossy (Blanc, Gris, Rose, Vert e Brun), ottenuta applicando uno smalto trasparente, lucido e brillante. La tecnica di bicottura tradizionale ha permesso di enfatizzare la ricchezza delle superfici, in modo particolare nei colori Vert e Brun, a cui è stato aggiunto uno smalto reagente tipico delle realizzazioni artigianali, che ha garantito una resa del colore eccezionale.

Developed from the concept that inspired Pico collection, Punto is a three-dimensional decorative element that can be used only on walls. The pattern is characterised by big sunken dots (Down) or elevated dots (Up) and finds its highest expression when used on large surfaces. Depending on how light hits the elements, they create unexpected chiaroscuro effects that enliven interiors. Both the Up and Down options are available in a single size of 4x31.5 cm, provided on meshes of five pieces each. The palette presents five colours in Matt finish (White, Grey, Red, Green and Blue) and five in the Glossy one (Blanc, Gris, Rose, Vert and Brun), which is obtained by applying a transparent, polished and bright glaze. The traditional double-firing production technique enhanced the preciousness of surfaces, especially in the shades Vert and Brun where a reacting enamel typical of handcrafted pieces guaranteed an exceptional colour rendering.

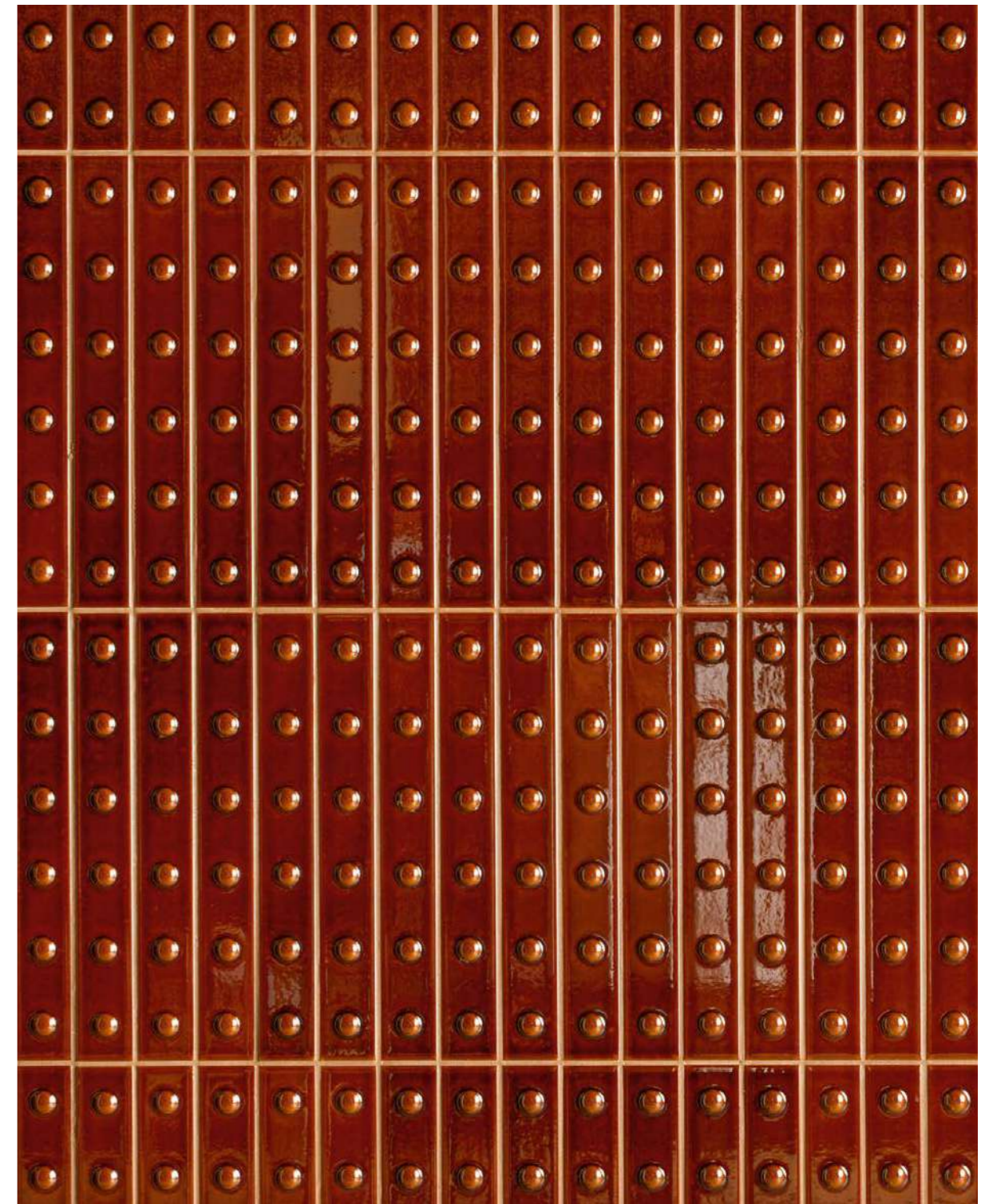



Punto Up Matt White
Opposite page – Punto Down Matt White

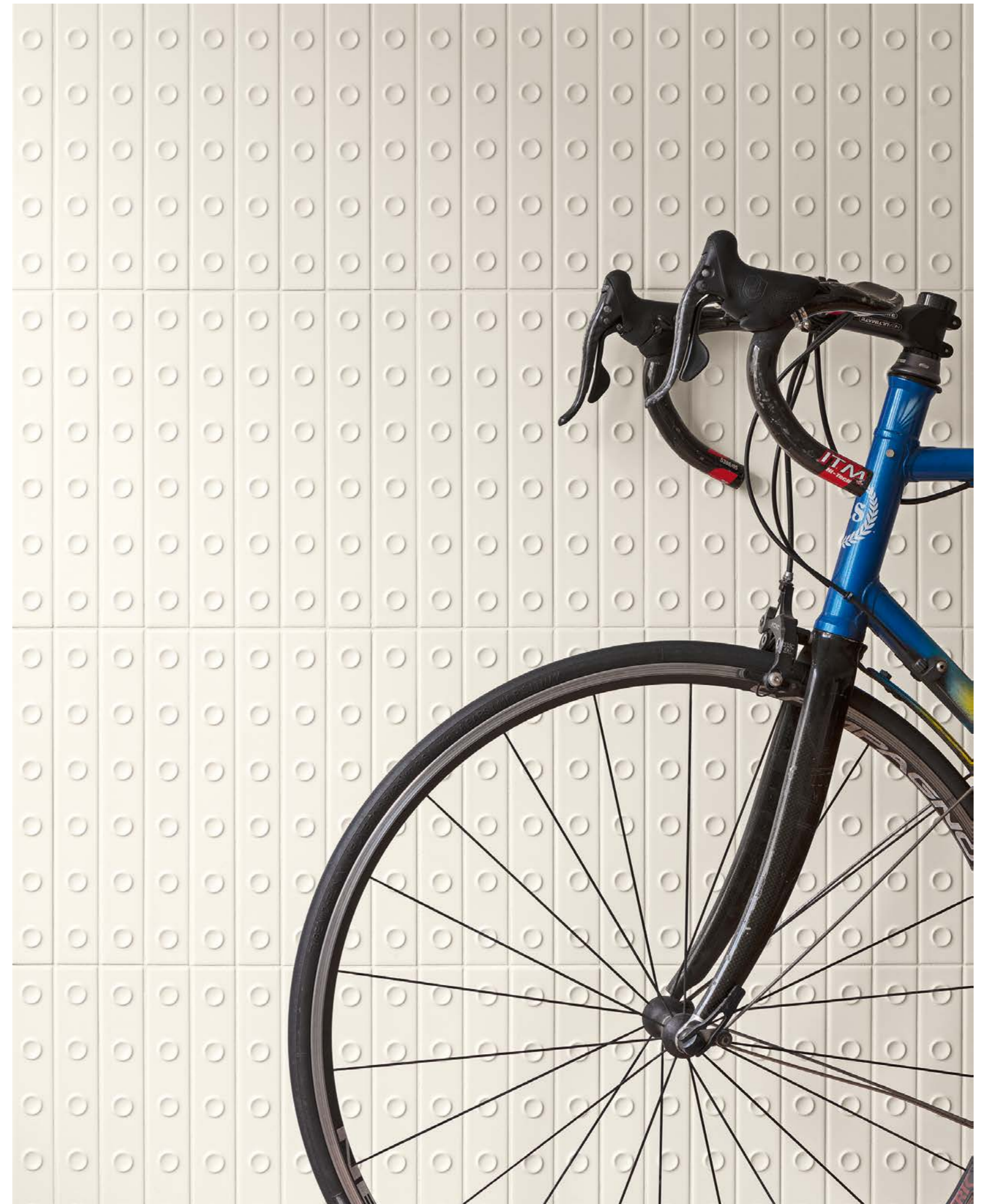

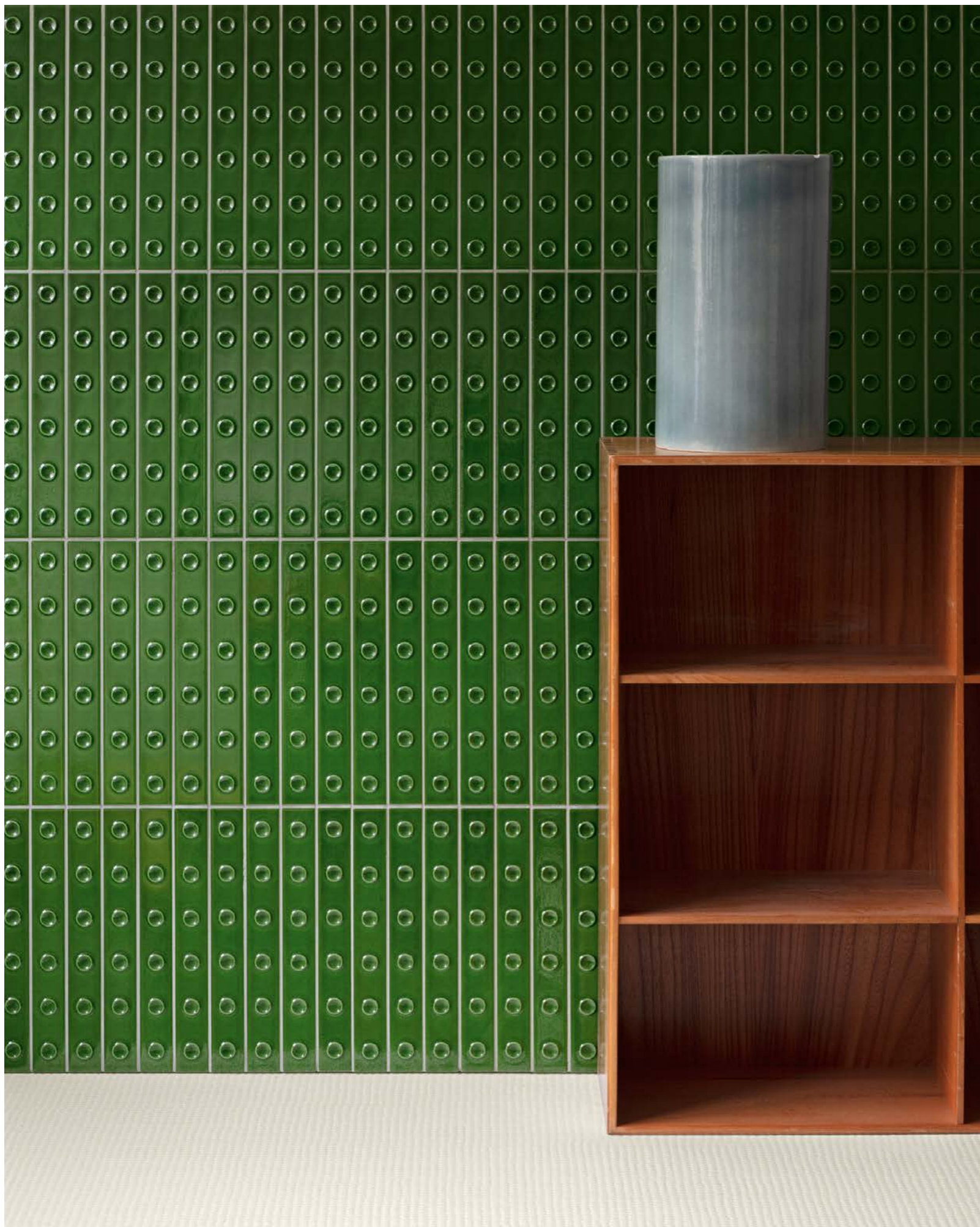

“È la prima volta che produciamo qualcosa di così decorativo. Punto ha un pattern davvero molto marcato, che trova la sua massima espressione usato su pareti di grandi dimensioni. La luce gioca un ruolo centrale quando incontra i punti, positivi e negativi, che nascono dalla superficie degli elementi”.

“It’s the first time we create something so decorative. Punto presents a really bold pattern that find its maximum expression when used on large walls. Light plays a central role when it meets the elevated and sunken dots on the surface of the elements.”

Ronan & Erwan Bouroullec

Opposite page – Punto Down Glossy Vert
Next page – Punto Up Glossy Brun





Puzzle

Edward Barber & Jay Osgerby

Puzzle rappresenta la libertà di creare infinite combinazioni randomiche attraverso l'accostamento di pattern grafici dal gusto moderno e contemporaneo, amplificando al massimo la possibilità di personalizzare gli spazi. Una collezione senza precedenti, che permette di disporre gli elementi – di dimensione 25x25 cm – in orizzontale e in verticale, su pavimenti e rivestimenti, seguendo forme regolari o astratte. Le combinazioni di colore danno vita a gradazioni eleganti che si sviluppano lungo le superfici, intensificandosi in alcuni punti e rarefacendosi in altri, comunicando con gli elementi architettonici e spaziali. In questo modo, Puzzle permette di progettare superfici dal carattere geometrico e figurativo sempre uniche, che ricordano mappe, isole, composizioni astratte e suggestive.

Puzzle represents the freedom of giving birth to endless random combinations by pairing up graphic patterns with a modern and contemporary aesthetic, thus maximising the possibility of customisation of the interiors. It's an unprecedented collection that allows to lay the elements (available in the size 25x25 cm) both horizontally and vertically, on floors and walls, following regular and abstract patterns. The colour combinations create refined effects, more or less intense, all along the surfaces, that communicates with the architecture and space elements. In this way, Puzzle allows to design always unique geometric and figurative surfaces, which recalls maps, isles, abstract and evocative compositions.





Wall: Puzzle Mineral. Floor: Puzzle Edge Mineral.
Opposite page – Puzzle Edge Stone

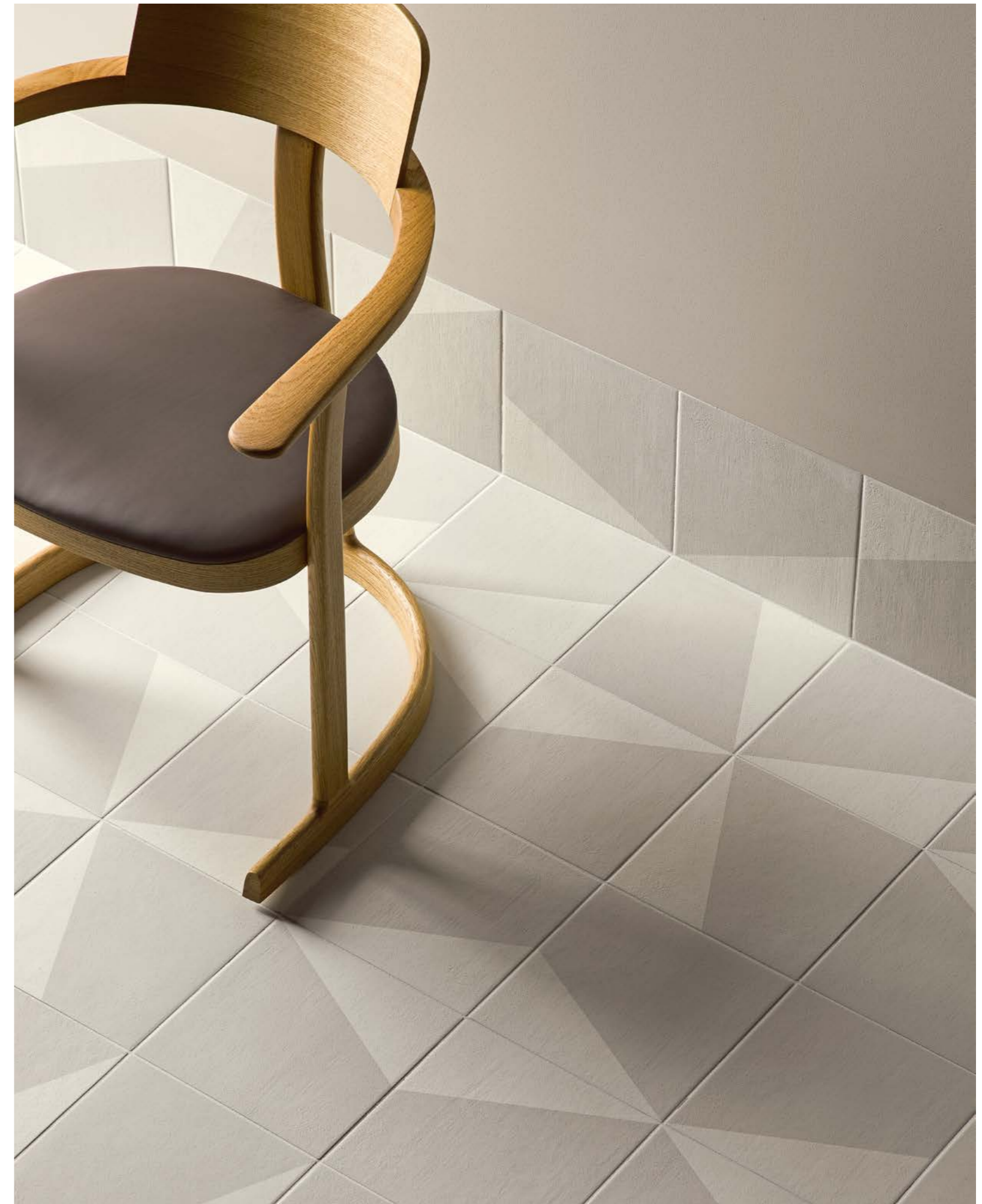



“Puzzle deriva dal nostro forte interesse per le geometrie; giochiamo sempre con forme e volumi, sul foglio e in tutte le tre dimensioni. Pensiamo che sia uno strumento davvero potente”.

“Puzzle stems from our continued interest in geometry; we are constantly playing with shapes and form both in three dimensions and on the page. We find that is a powerful tool.”

Edward Barber & Jay Osgerby

Previous page – Puzzle Faroe
Opposite page – Puzzle Smoke, Anglesey, Powder





Opposite page – Puzzle Coal, Creta
Wall: Puzzle Edge Slate

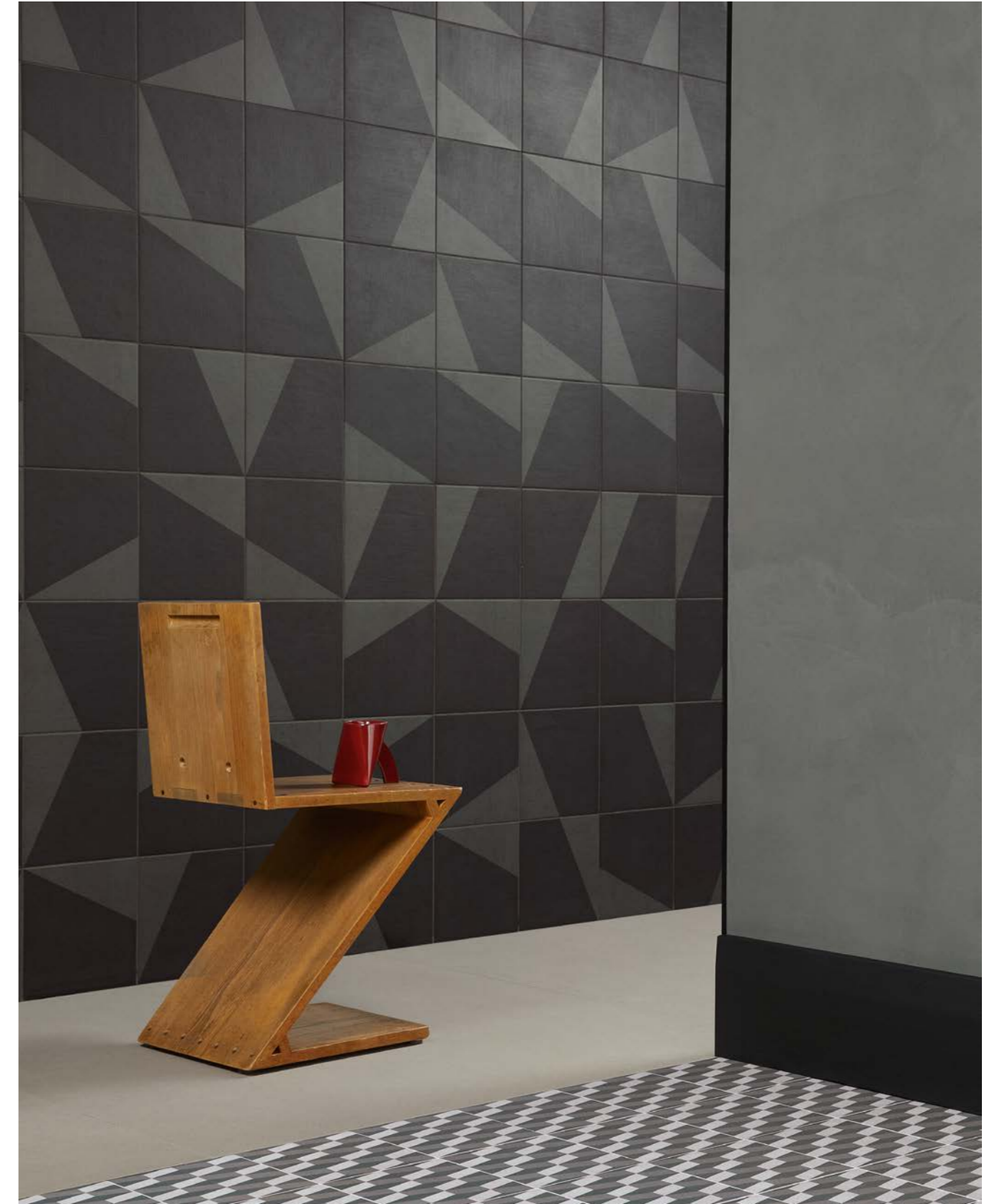

Rombini Ronan & Erwan Bouroullec

Rombini è un percorso fatto di vibrazione ceramica. La collezione presenta due diversi moduli dalla grande forza cromatica, che possono essere combinati tra loro donando agli ambienti un'estetica dal gusto architettonico: Losange, che richiama un mosaico contemporaneo e può essere utilizzato sia a pavimento che a rivestimento, e Triangle, elemento a rilievo pensato specificamente come rivestimento. In occasione della riedizione, alle varianti Large e Small già esistenti del modulo Triangle, si aggiunge un nuovo formato Extra Small nelle dimensioni 2x31,5 cm e la nuova finitura Glossy nei colori Blanc, Gris, Rose, Vert e Brun, declinata su tutti gli elementi in gamma. L'adozione della tecnica di produzione in bicottura tradizionale ha permesso di esaltare la ricchezza delle superfici, ricoperte con uno smalto trasparente, lucido e brillante. In particolare, le varianti Vert e Brun sono realizzate attraverso l'applicazione di uno smalto reagente, tipico delle realizzazioni artigianali, che ha garantito una resa del colore eccezionale.

Rombini is a journey made of ceramic vibration. The collection presents two different modules of great chromatic strength, that can be combined to give the interiors an architectural aesthetic: Losange, which recalls a contemporary mosaic and can be used on both floors and walls, and Triangle, a three-dimensional element specifically developed for walls. On the occasion of the new edition, the already existing variants Triangle Large and Small are joined by the new Extra Small format in the size 2x31,5 cm, as well as by a new Glossy finish in the colours Blanc, Gris, Rose, Vert and Brun, declined on the entire range. Using the traditional double-firing production technique allowed to enhance the preciousness of surfaces, coated with a transparent, polished and bright glaze. Especially, the shades Vert and Brun are obtained by applying a reacting enamel typical of handcrafted pieces, that guaranteed an exceptional colour rendering.



Rombini Triangle Extra Small Glossy Gris, Accents Paint: Limetouch Chalk
Next Page – Rombini Triangle Small Matt White



Rombini Triangle Large Matt White





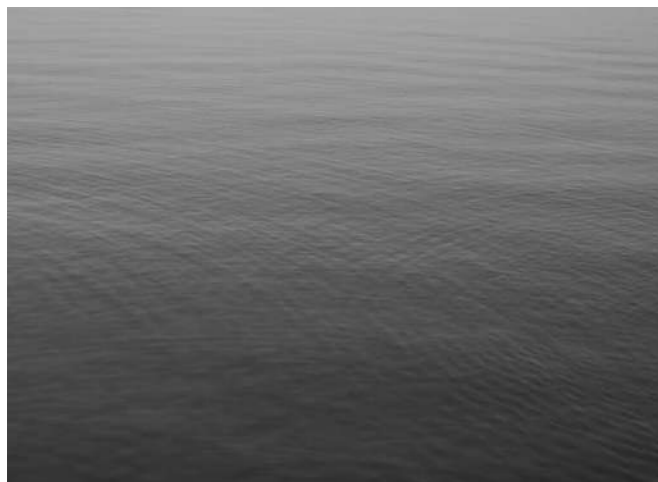

Che tipo di rapporto avete con la ceramica e con Mutina?

Per noi è una materia vivente. Siamo sempre stati attratti dalla ceramica, ma la prima volta che ci è stato proposto di disegnare dei rivestimenti è stato con Mutina: non una semplice azienda, ma un progetto artistico e intellettuale. Le collezioni che abbiamo creato insieme sono il risultato di un fortunatissimo scambio tra i nostri due mondi, dove tutto si lega e comunica in armonia.

Com'è nata la collezione Rombini?

Rombini è il risultato di una ricerca su un sistema ceramico dove la fuga perde importanza, come se si mettesse a fuoco non semplicemente un pattern, ma la superficie nella sua totalità. Una volta posati, gli elementi di Rombini sembrano quasi un dipinto.

Nel 2021, è stata presentata una nuova edizione di Rombini. Che tipo di intervento è stato fatto sul range di collezione?

La nuova edizione di Rombini è stata arricchita con un nuovo formato Extra Small e la versione smaltata: in alcuni punti è quasi trasparente e dona una brillantezza unica, crea degli effetti di colore e geometria molto particolari a contatto con la luce che cambia durante il giorno.

Qual è il fil rouge che unisce le collezioni che avete progettato per Mutina?

Tutte queste collezioni funzionano benissimo anche usate insieme. Le soluzioni e i codici estetici che si possono ottenere sono pressoché infiniti: lo stesso pezzo, opaco o lucido, rosa o verde, restituisce sensazioni diverse. La palette colori, combinata a diversi trattamenti della materia, consente una grande varietà e, allo stesso tempo, grande coerenza.

What kind of relationship do you have with ceramics and with Mutina?

To us, it is a "living" material. We've always been interested in ceramic, but Mutina has been the first brand asking us to design coverings. It is not just a company, but artistic and intellectual project. The collection we designed together are the result of the amazing exchange between our two worlds, where everything is linked and interact with harmony.

How did the Rombini collection develop?

Rombini is the result of a research focused on developing a ceramic module where the joint loses its importance, as if the surface is brought into focus in its entirety. Once installed, the elements of the collection resemble a painting.

In 2021, a new edition of Rombini has been presented. What kind of work has been done on the collection range?

The new edition has been enriched with a new Extra Small format and the Glossy finish: in some parts it is almost transparent and gives an unprecedented brightness, creating particular geometry and colour effects when it comes into contact with the light that changes throughout the day.

What's the common thread among the collections you have designed for Mutina?

They all blend perfectly also if used together. They allow to obtain almost infinite solutions and aesthetic codes: the same element, matt or glossy, pink or green, evokes different sensations. The colour palette, paired with different ways of processing ceramic, provides great variety and coherence at the same time.

Wall: Rombini Triangle Small Matt Blue, Large Matt Blue.
Floor: Rombini Losange White.

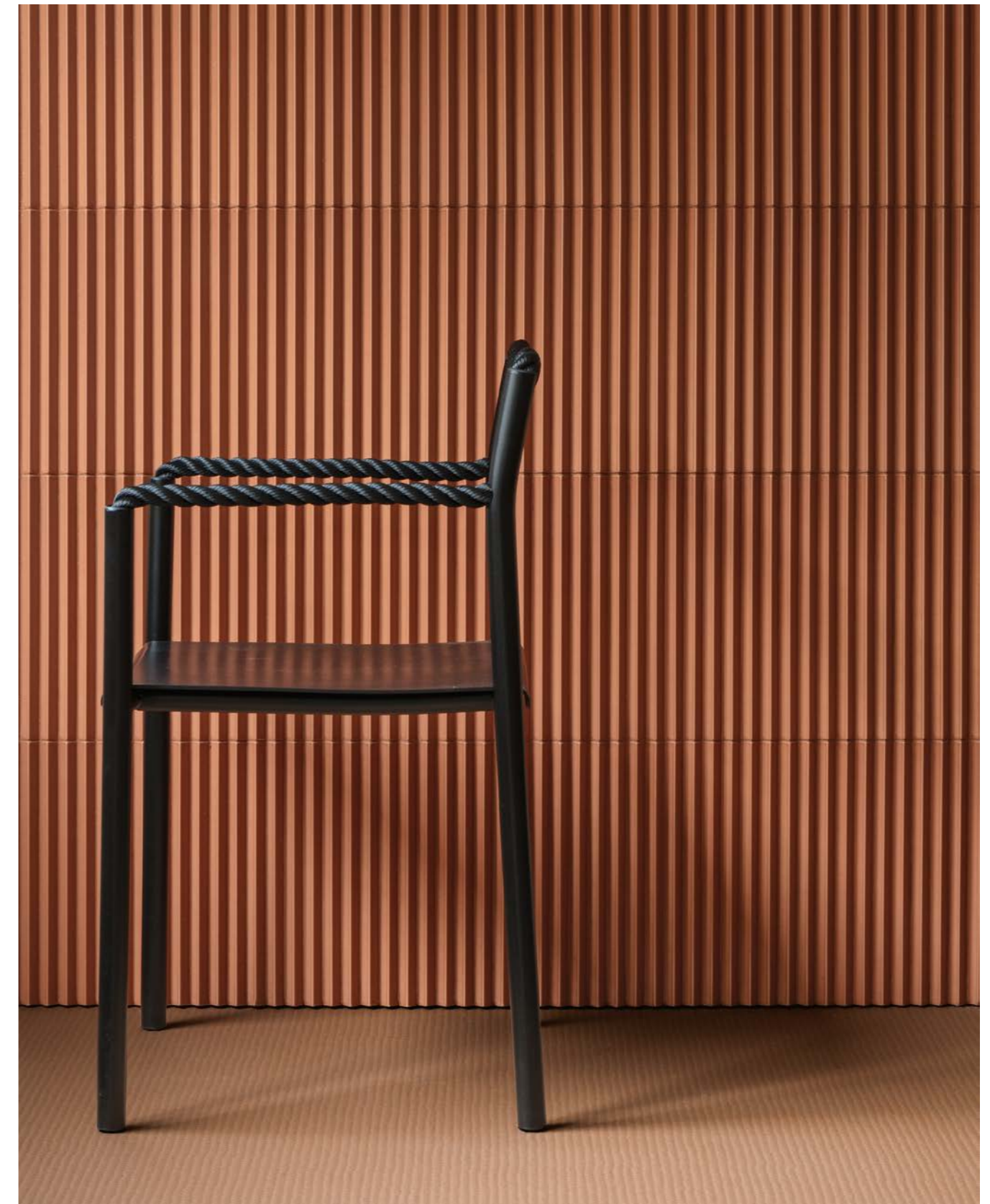

Rombini Triangle Extra Small Matt Red

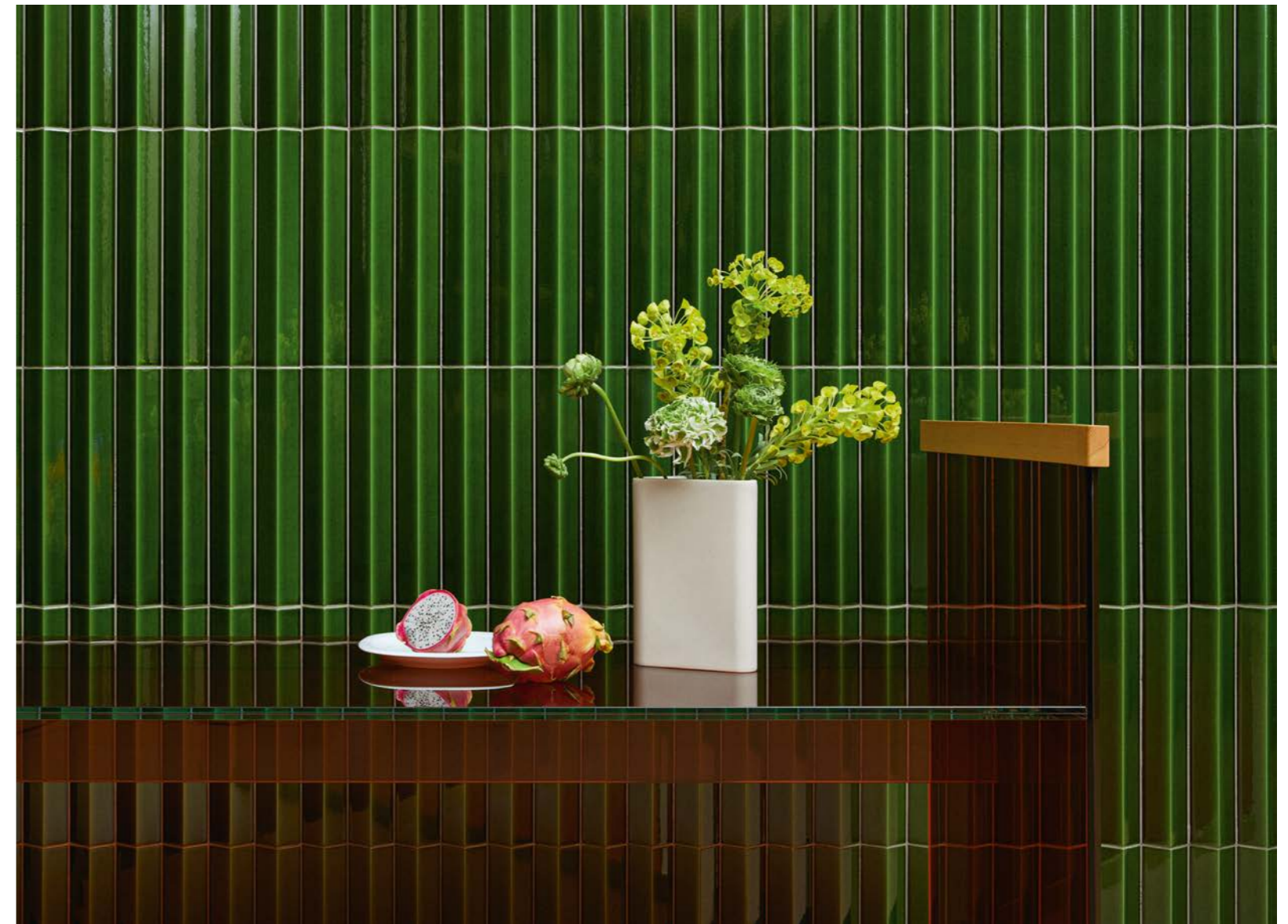
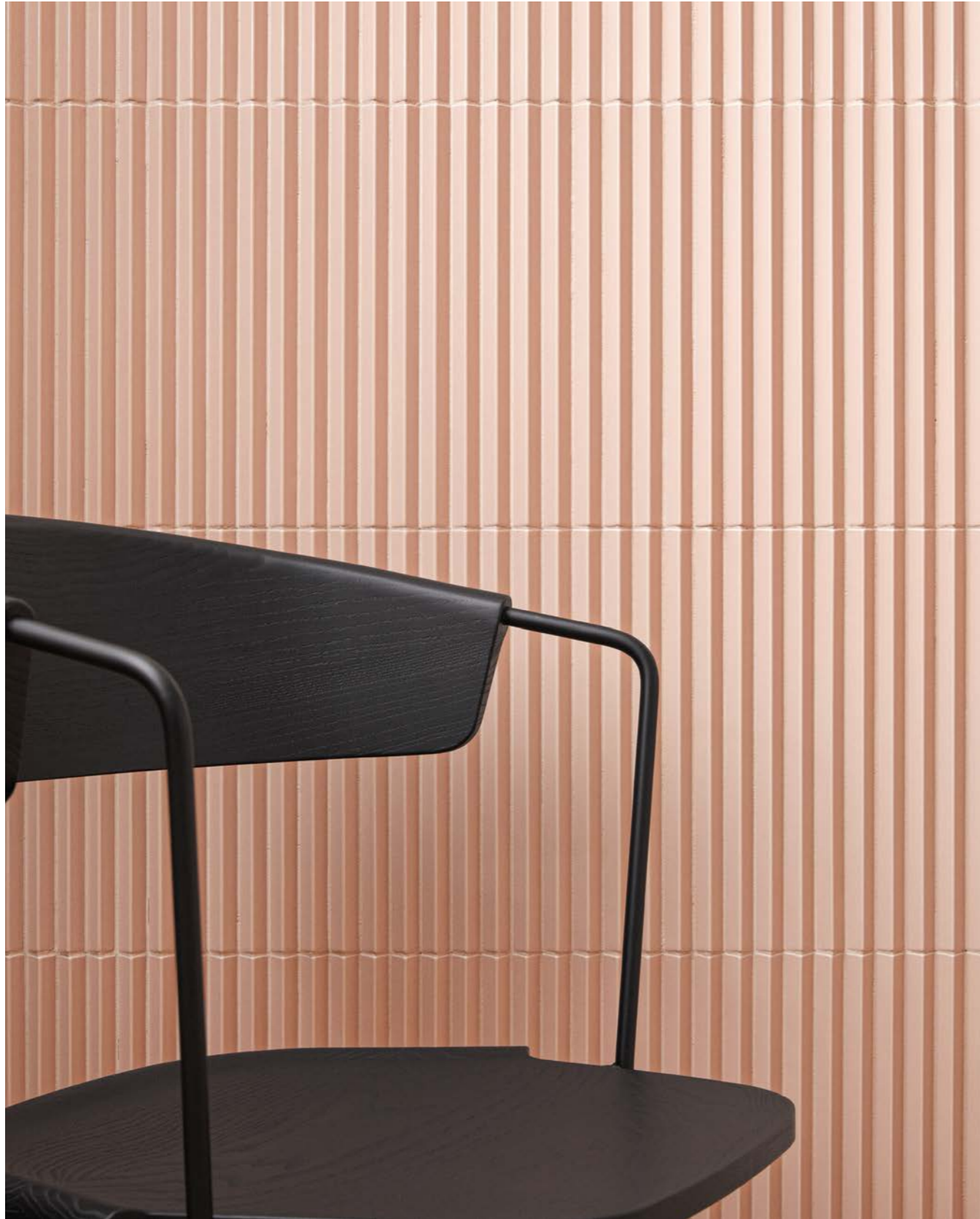

Tape Raw Edges

Tape riproduce l'illusione di rotoli di grafiche colorate che vengono adagiati su piastrelle nude, consentendo di creare ambienti diversi e varie atmosfere. Il prodotto si compone di una prima leggera grafica di fondo, quasi impercettibile, che richiama l'effetto gessoso delle superfici dei carreaux-ciment, e di una seconda gamma di otto diversi pattern – che possono venire combinati facilmente grazie ai due fondi base, uno bianco e uno nero – realizzati nei cinque toni che caratterizzano la collezione: bianco, blu, verde, marrone e nero. Prodotti in grès porcellanato smaltato, in un unico formato di 20,5x20,5 cm, i moduli possono essere abbinati liberamente, creando morbide transizioni da un pattern all'altro. Dando vita a combinazioni vivaci e inaspettate, che ridefiniscono gli spazi attraverso un'estetica vagamente grafica.

Tape reproduces the illusion of rolls of colourful patterns that rest on the raw tiles, creating different settings and various atmospheres. The design consists of a first slight, almost imperceptible pattern on the base tile that evokes the chalky effect of the surfaces of the carreaux-ciment, and a range of eight patterns – that can be easily combined thanks to the base tiles, one white and one black – all in the five shades of the range: white, blue, green, brown and black. Tape is suitable for both floor and wall tiles, for indoor and outdoor use. The collection is made in glazed porcelain stoneware, in a single size: 20,5x20,5 cm. The tiles can be freely combined, thus creating soft transitions from a pattern to another. This gives birth to vibrant and unexpected combinations that re-defined spaces through a slightly graphic aesthetic.

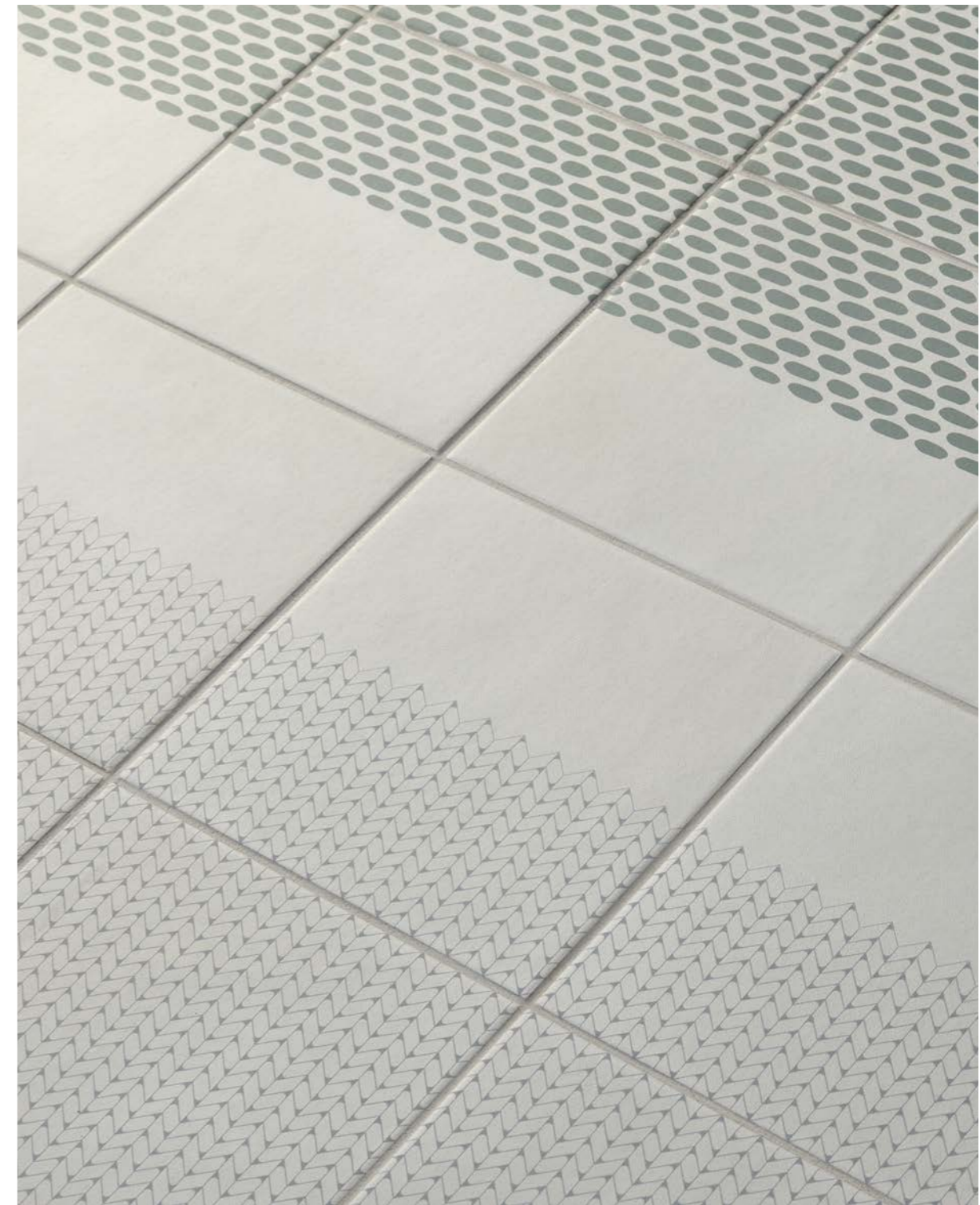

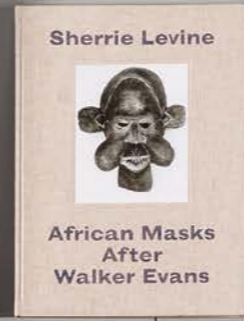
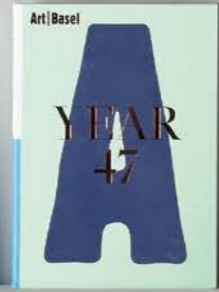
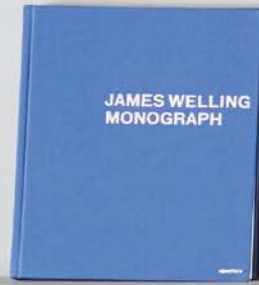

“Abbiamo immaginato questa collezione come se fosse composta da rotoli di forme colorate che si appoggiano alle piastrelle nude, creando così ambienti diversi grazie alla vastità delle combinazioni possibili”.

“We imagined this collection to seem as if it was made out of rolls of colourful patterns that rest on the raw tiles, creating different settings thanks to the vast number of possible combinations.” We find that is a powerful tool.”

Raw Edges

Previous page – Wall: Tape Cobble Half Green, Cobble Green.
Floor: Tape Cobble Green, Cobble Half Green, Base White, Grainy Half Green, Grainy Green.

Opposite page – Tape Cobble Half White, Cobble White, Cobble Black, Cobble Half Black.

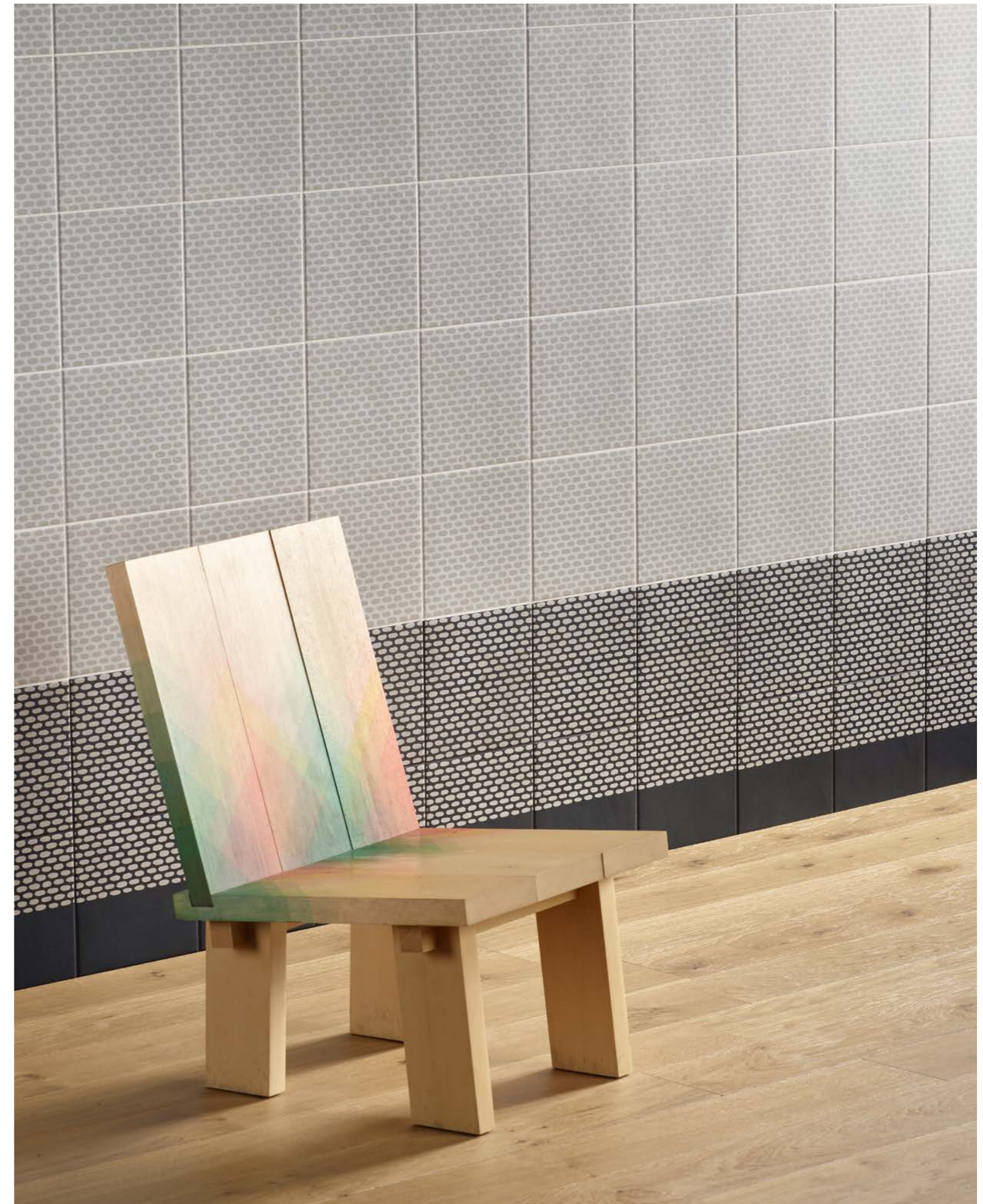



Tape Mesh Brown, Mesh Half Brown, Cobble Half Brown, Cobble Brown. Table: Zigzag Half Brown, Zigzag Brown.

Wall: Tape Mesh Blue, Mesh Half Blue, Base White, Grainy Half Blue, Grainy Blue, Zigzag Half Blue, Zigzag Blue.
Floor: Tape Zigzag Blue, Grainy Blue.



Wall: Tape Zig Zag Black, Zig Zag Half Black,
Grainy Black, Grainy Half Black, Accents Paint: Yarn Matt
Floor: Tape Cobble Black, Cobble Half Black, Base Black.



Teknotessere Mutina Team

Teknotessere rappresenta la contemporaneità e la semplicità, sotto forma di elemento ceramico. La collezione si compone di piccole piastrelle della dimensione di 1x1 cm, geometricamente rigorose ed essenziali, che si diramano in cinque nuance sobrie e raffinate: bianco, cemento, cenere, nero e fango. Il minimalismo che caratterizza i suoi elementi, permette di combinare Teknotessere ad altre collezioni Mutina all'interno di uno stesso ambiente, creando atmosfere sempre uniche e inedite.

Teknotessere represents modernity and simplicity, in the form of ceramic elements. The collection is made of small 1x1 cm tiles, geometric and essential, in five sober and refined colours: bianco, cemento, cenere, nero and fango. The minimalism of Teknotessere allows for it to be easily complimented with other Mutina collections in the same environment, thus creating unique and unprecedented atmospheres.

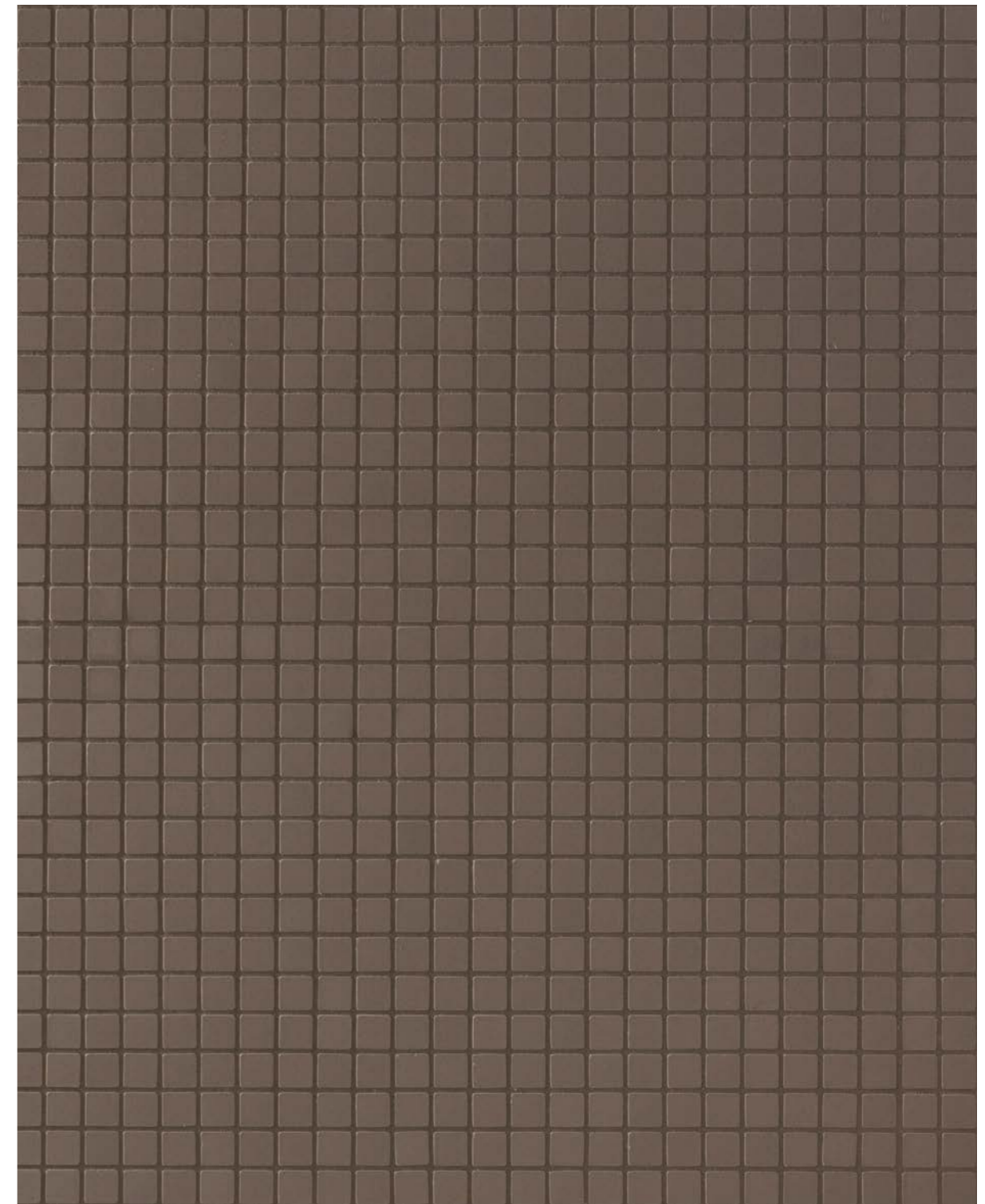

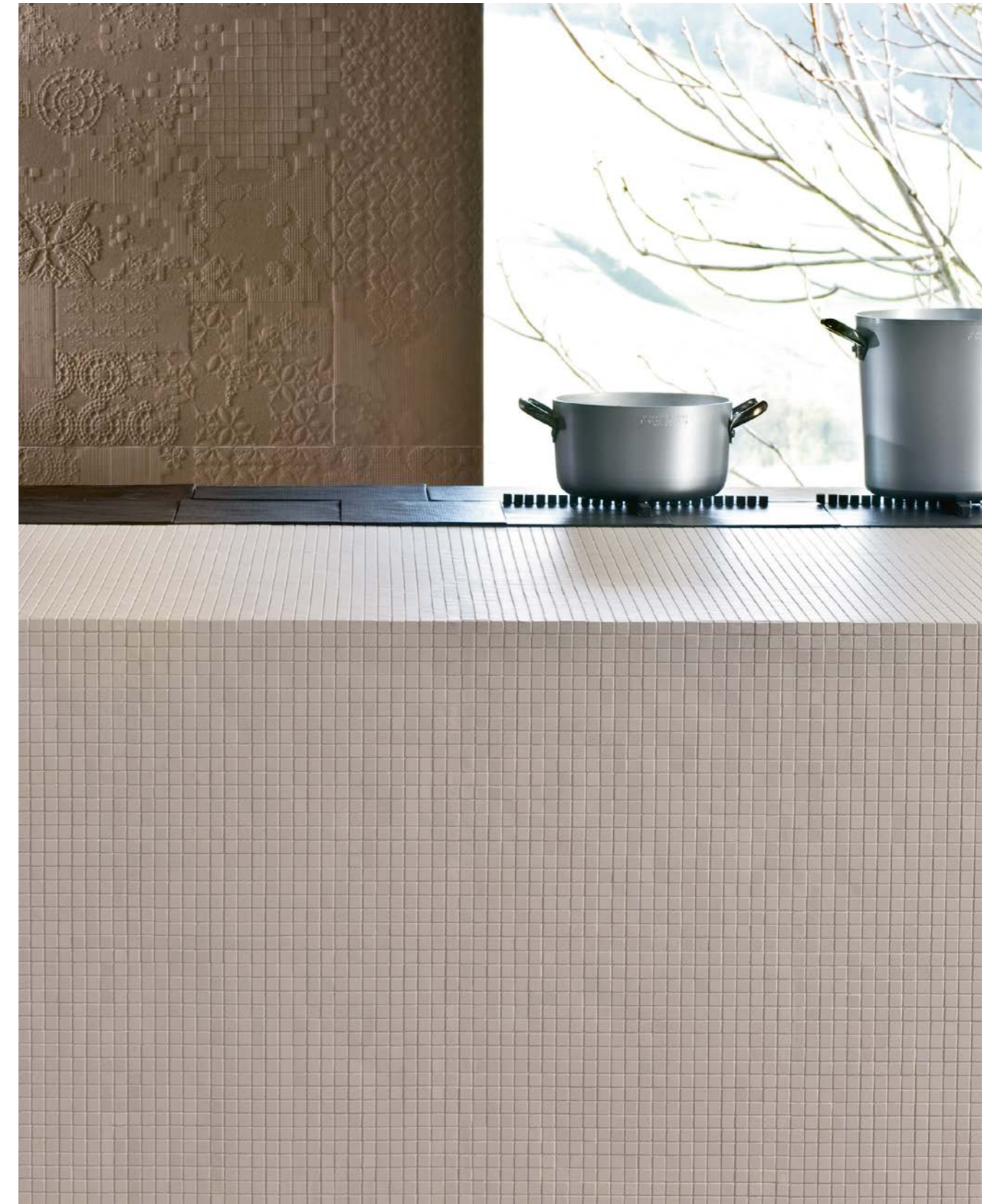

Tex Raw Edges

Tex costituisce una reinterpretazione delle texture tessili, in formato ceramico. Gli elementi della collezione costituiscono un ingrandimento semplificato della lavorazione a maglia di base e possono essere disposti in tre pattern principali, a loro volta declinati in otto diverse colorazioni. La produzione di Tex esalta la varietà delle texture, l'autenticità dei colori e le qualità tattili dello smalto, che crea effetti di luce più o meno irregolari e saturi. Con l'obiettivo di amplificare l'effetto sorpresa e stimolare creatività e personalizzazione degli ambienti, le tre tonalità vengono inserite nel packaging in modo casuale. In questo modo, durante la posa sarà possibile ottenere composizioni inaspettate. Vi sono poi i Runner, installazioni su rete con pattern predefiniti, simili a mosaici, che permettono di posizionare gli elementi grafici in posizioni particolari sia a pavimento che a rivestimento.

Tex is a re-interpretation of textile textures, entirely ceramic. The shape of the tiles consists of a simplified enlargement of the basic knitted stitch and can be arranged in three main patterns, each of which can be declined in eight different nuances. The production of Tex enhance the variety of the textures, the authenticity of colours and the quality of the glaze, that gives birth to irregular and more or less saturated light effects. With the aim of enhancing the surprise effect and to increase the creativity and personalisation of the environments, the three shades will be placed randomly in the packages. By this, when installing Tex, arbitrary arrangements could be achieved. There are also patterns named Runner: premade installations arranged on a mesh similar to mosaic settings, which allow to locate graphic elements in particular places, both on floors and walls.



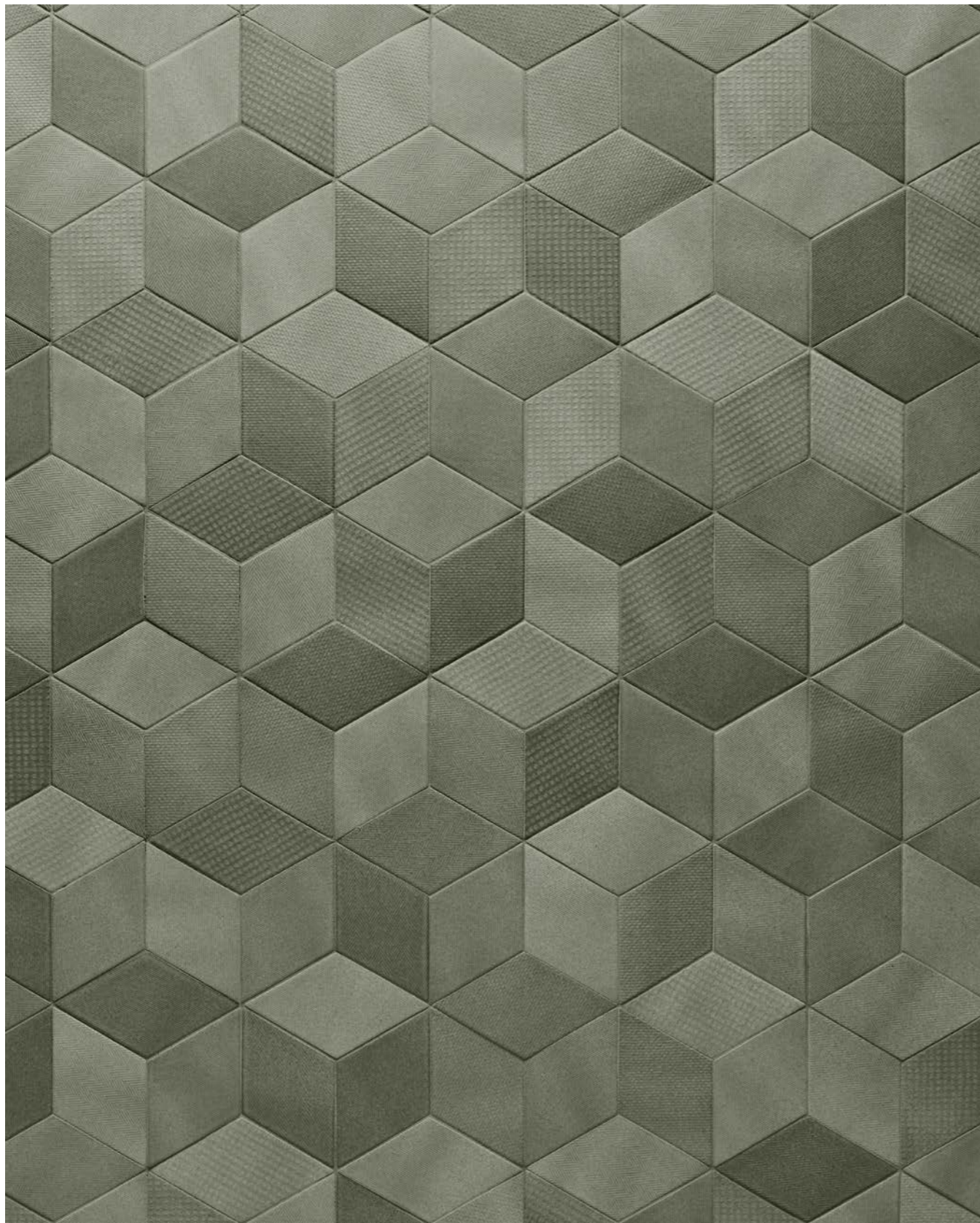

Tex Olive
Opposite page – Wall: Tex White, Olive, Cream. Floor: Tex White.

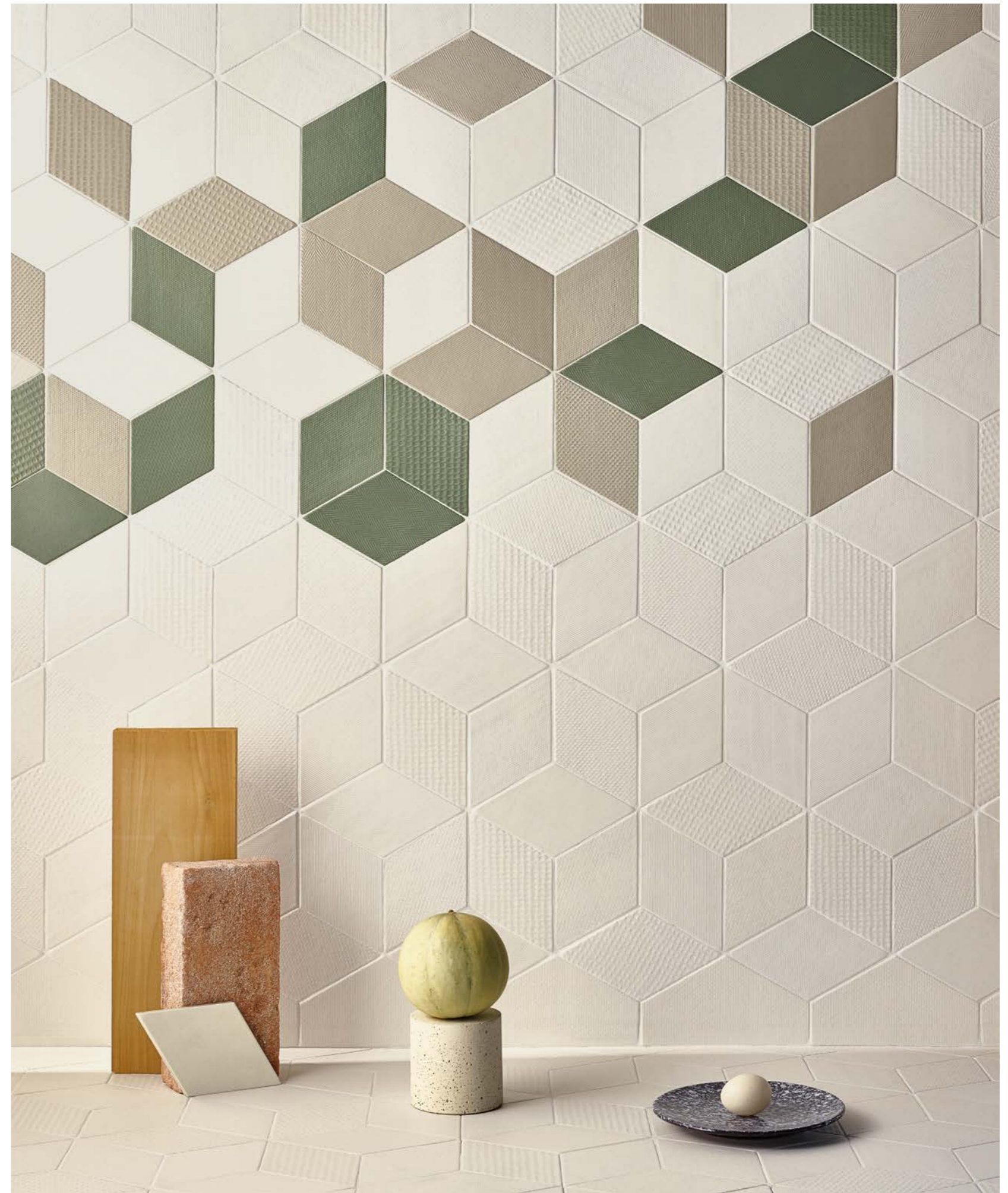

Ricordate il vostro primo incontro con il team Mutina?

Certo, è stato a Milano, durante gli Edida Award del 2009. Mutina era stata premiata per Déchirer e noi per Stack di Established & Sons. Qualche settimana dopo siamo stati invitati nella sede di Sassuolo per discutere di una potenziale collaborazione. Non avevamo mai pensato di progettare degli elementi in ceramica prima di conoscere il team Mutina, ma ci siamo subito innamorati della loro personalità e del loro approccio al design, quindi non abbiamo avuto altra scelta.

Come è stata sviluppata la collezione Tex?

Siamo andati da un grosso commerciante di Tel Aviv, che ha una collezione infinita di tessuti sparsi in modo casuale su quattro enormi pavimenti. Vengono date delle forbici per potersi tagliare i campioni in autonomia, quindi ci è bastato recuperare più pezzi che potevamo a cui ispirarci! Poi li abbiamo portati a Londra, nel nostro studio, e su ognuno di essi è stata pressata della plastilina, riproducendo la trama tessile sulla superficie bianca. Dopo che Massimo li ha visti, non c'è voluto molto per ultimare la collezione. Quei campioni sono ancora conservati nel nostro studio.

Tex presenta non solo diversi colori, ma anche varie texture sulla superficie degli elementi. Che tipo di esperienza volete creare attraverso questo aspetto particolare?

Volevamo ottenere una superficie materica, impossibile da non toccare. In quel periodo stavamo lavorando a dei parquet in legno ed eravamo molto interessati allo sviluppo di pattern all'interno di una griglia predefinita. Tex doveva trasmettere una sensazione simile, quindi abbiamo sfruttato l'adattabilità della ceramica, prendendo in prestito le trame dei tessuti per ottenere questo livello di tattilità.

Che ruolo ricopre la creatività in termini di layout e applicazioni possibili all'interno della collezione?

La collezione è estremamente versatile ed era molto importante per noi che gli utenti finali si sentissero liberi di giocare con gli elementi, creando le proprie combinazioni di pattern e colori. Tutt'ora ci stupiamo di come architetti, interior designer e clienti utilizzano Tex nei loro progetti.

Do you remember the first time you met the Mutina team?

Of course, it was at the 2009 Edida Award event in Milan. Mutina had received the prize for Déchirer and us for Established & Sons' Stack. A few weeks later we were invited to their Headquarters in Sassuolo to discuss a potential collaboration. We had never considered working on ceramic tiles before meeting the Mutina team, but we absolutely fell in love with them and their approach to design, so it didn't leave us any other option.

How did the Tex collection develop?

We went to this huge textile dealer in Tel Aviv, who has an endless collection of textiles randomly spread over four very big floors. They give you scissors to cut the samples you want by yourself, so we simply collected as many inspiring pieces as we could! We later brought them to our studio in London and pressed plasticine on each sample, reproducing the textile's pattern onto a white surface. From the moment Massimo saw them, it didn't take long to finalise the collection. We still have those samples in our studio.

Tex features not only different colours, but also various textures on the surface of the elements. What kind of experience did you aim at creating through this particular aspect?

We wanted to achieve a tactile surface that you couldn't resist but touch. At that time, we were working on wooden parquet floors and we were really into creating colourful patterns within a given grid. For Tex, we aimed at obtaining something with a similar feel, so we used the adaptive character of ceramics and borrowed textures from textiles to achieve this level of tactility.

What role does creativity play in terms of layouts and possible applications within the collection?

The collection is highly versatile and it was very important for us to allow the users freedom to play around and come up with their own patterns and colour combinations. It is still amazing to see how architects, interior designers and customers are using these tiles in their projects.

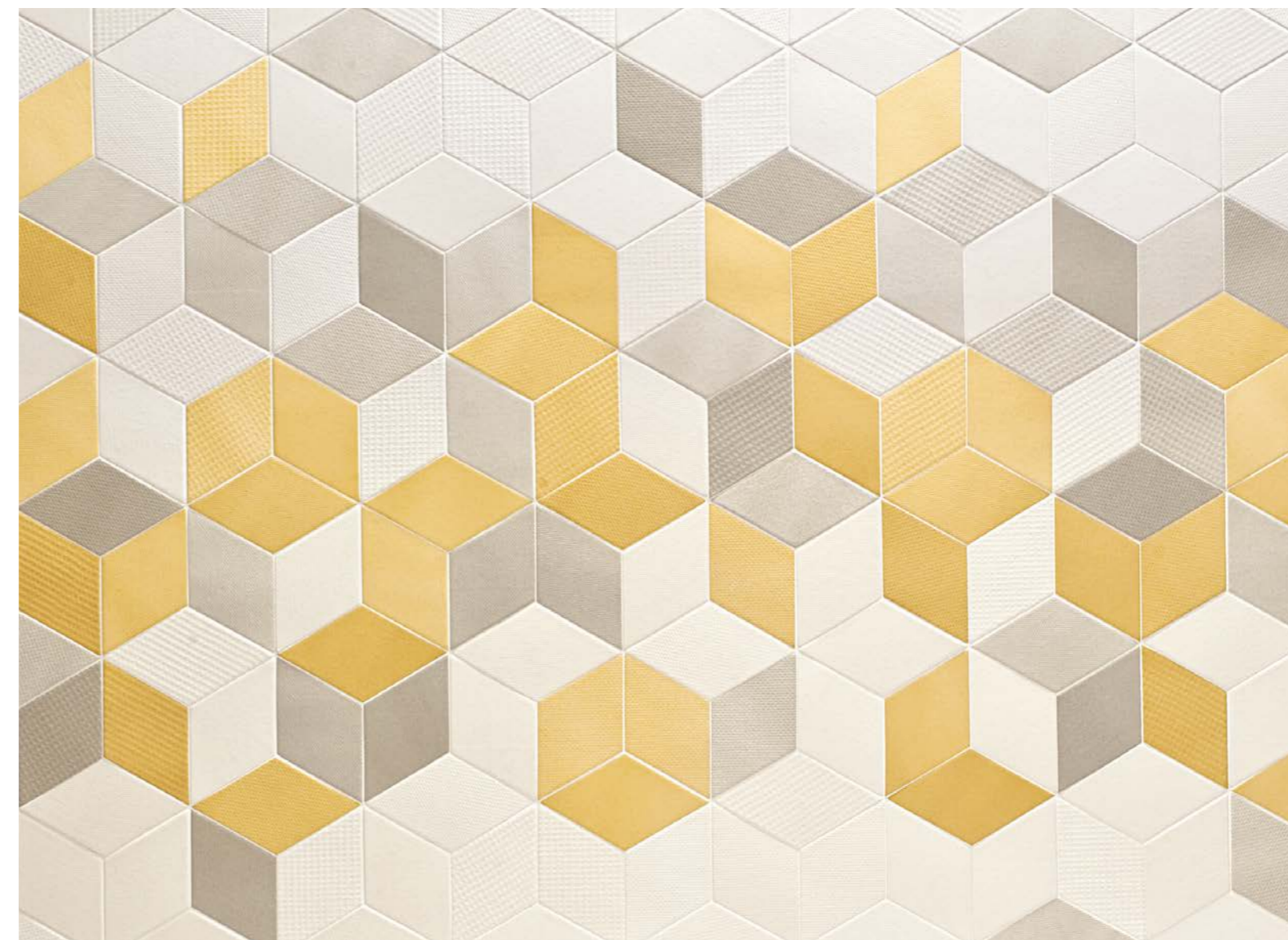

Tex White, Cream, Yellow

Opposite page – Tex Grey, Runner 6 Grey
Tex Blue, Cream, White, Blue Battiscopa

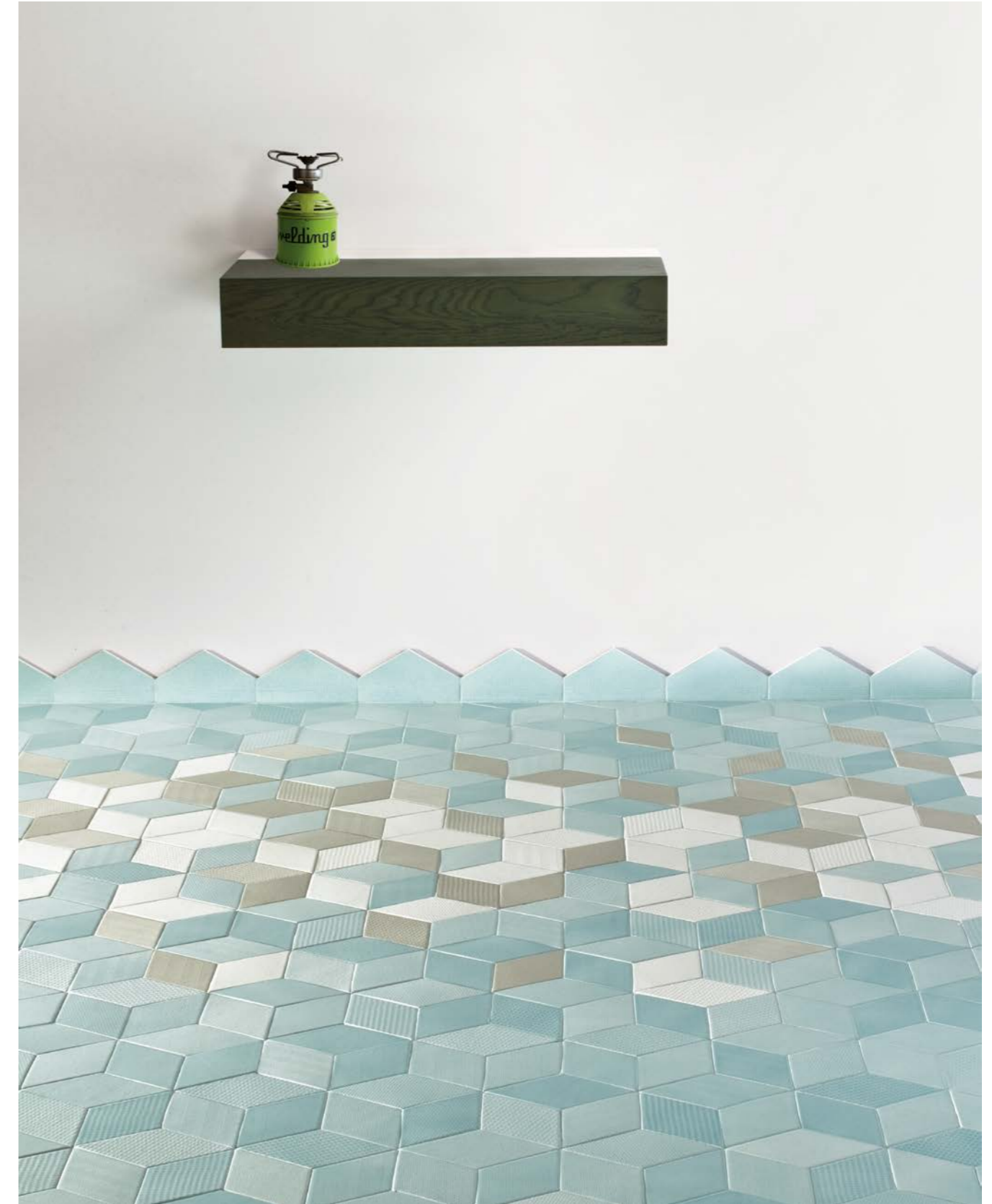

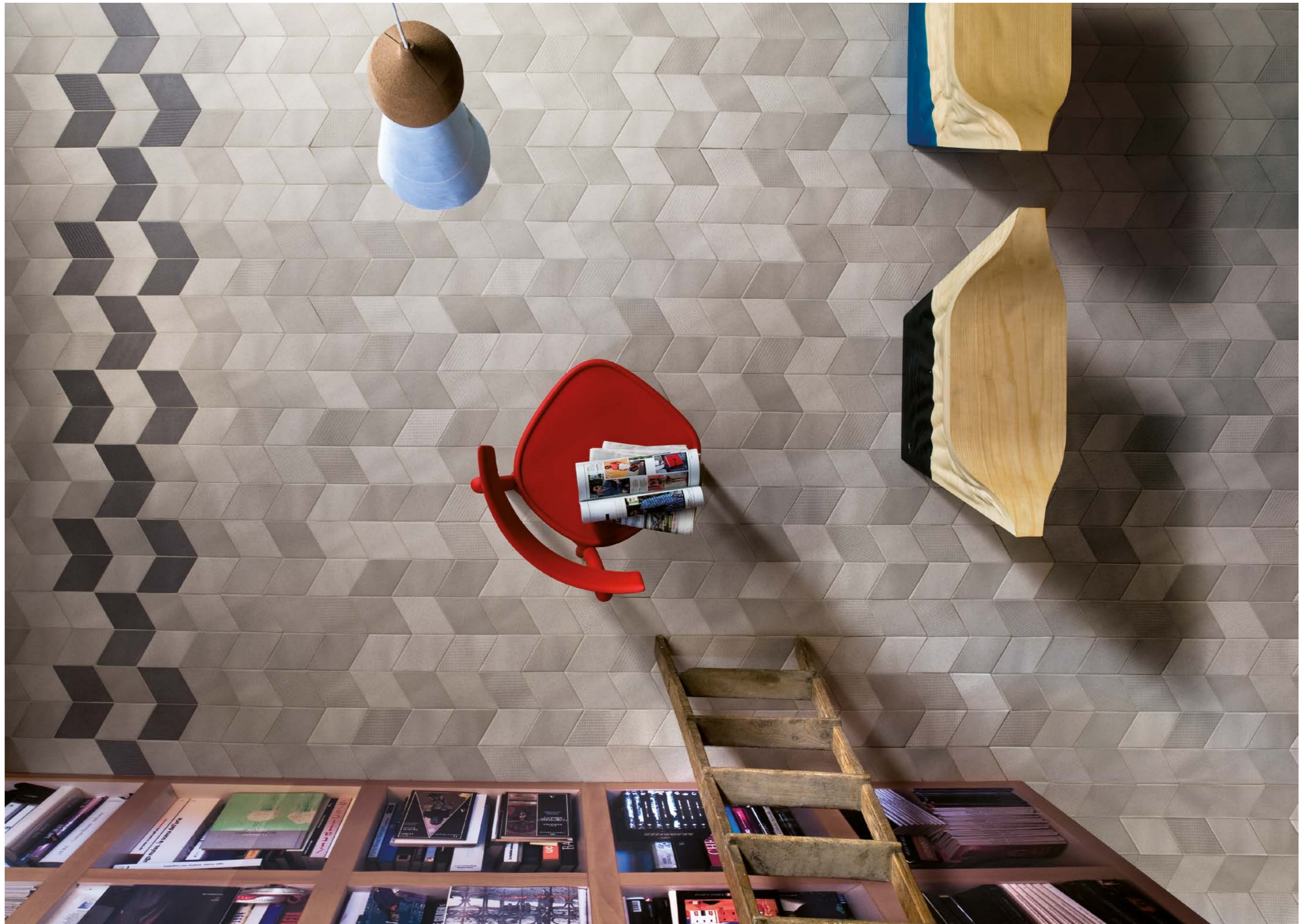

Tierras

Patricia Urquiola

Tierras si sviluppa a partire dalla tradizione artigianale mediterranea, concentrandosi sul concetto di sedimentazione per dare vita a una collezione i cui elementi sembrano emergere dalla terra. Una rivisitazione della manifattura tradizionale, dove diversi tipi di lave, terracotta e terre si combinano e miscelano tra di loro, arricchendo e ammorbidendo la base ceramica nera su cui vengono depositate. Realizzata in grès porcellanato non smaltato a impasto omogeneo, con l'ausilio dell'innovativa tecnologia Continua, gli elementi risultano fortemente materici e caratterizzati da una palette di colori naturali ma intensi, profondi, una serie di nuances terrose che vengono saturate dalla base di fondo. A queste viene abbinata una palette di stucchi a contrasto, non vendibili direttamente ma facilmente reperibili sul mercato: una lettura ironica della fuga che consente di reinterpretare gli ambienti in chiave moderna.

Tierras came about from the Mediterranean artisanal tradition and focuses on the concept of sedimentation, in order to create a collection where the elements seem to come from earth. It's a re-interpretation of traditional craftsmanship, where different kind of terracotta and clays combine and mix, enriching and softening the black base of recycled ceramics on which they deposit. Realised in unglazed porcelain stoneware using the innovative Continua technology, the tiles results extremely tactile and the colour palette is characterised by natural yet rich and deep earthy shades, saturated by the black base underneath. These are combined with a series of putties in contrast with the previous nuances, not directly for sale but easily available on the market: an ironic interpretation of the joint that gives the environments a contemporary look.

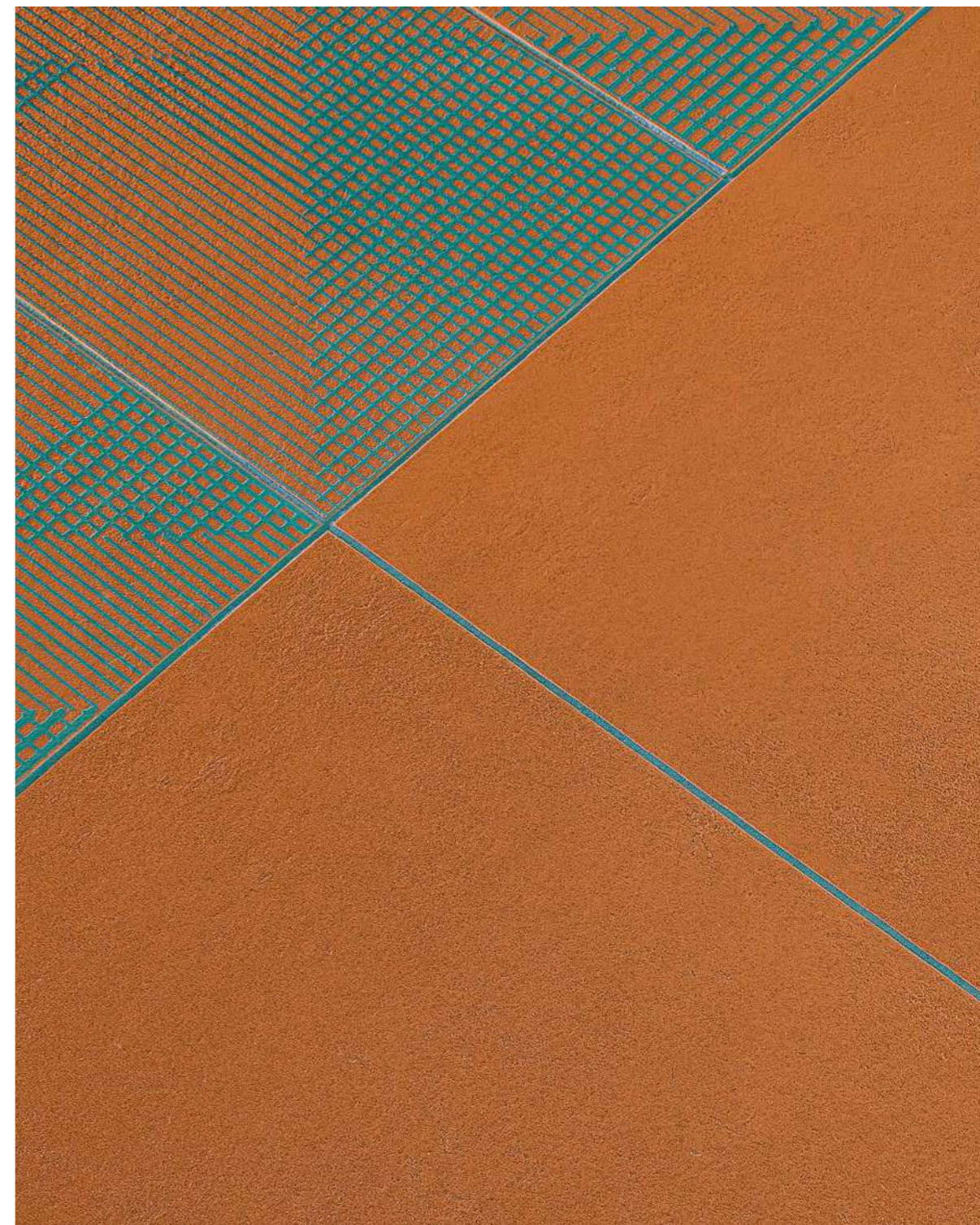



Wall: Tierras Triomix 2 Blush, Sand, Brick. Floor: Tierras Sand.
Opposite page – Wall: Tierras Rust, Frame Rust. Floor: Tierras Rust
Next page – Tierras Triomix 3 Ash, Humus, Rust

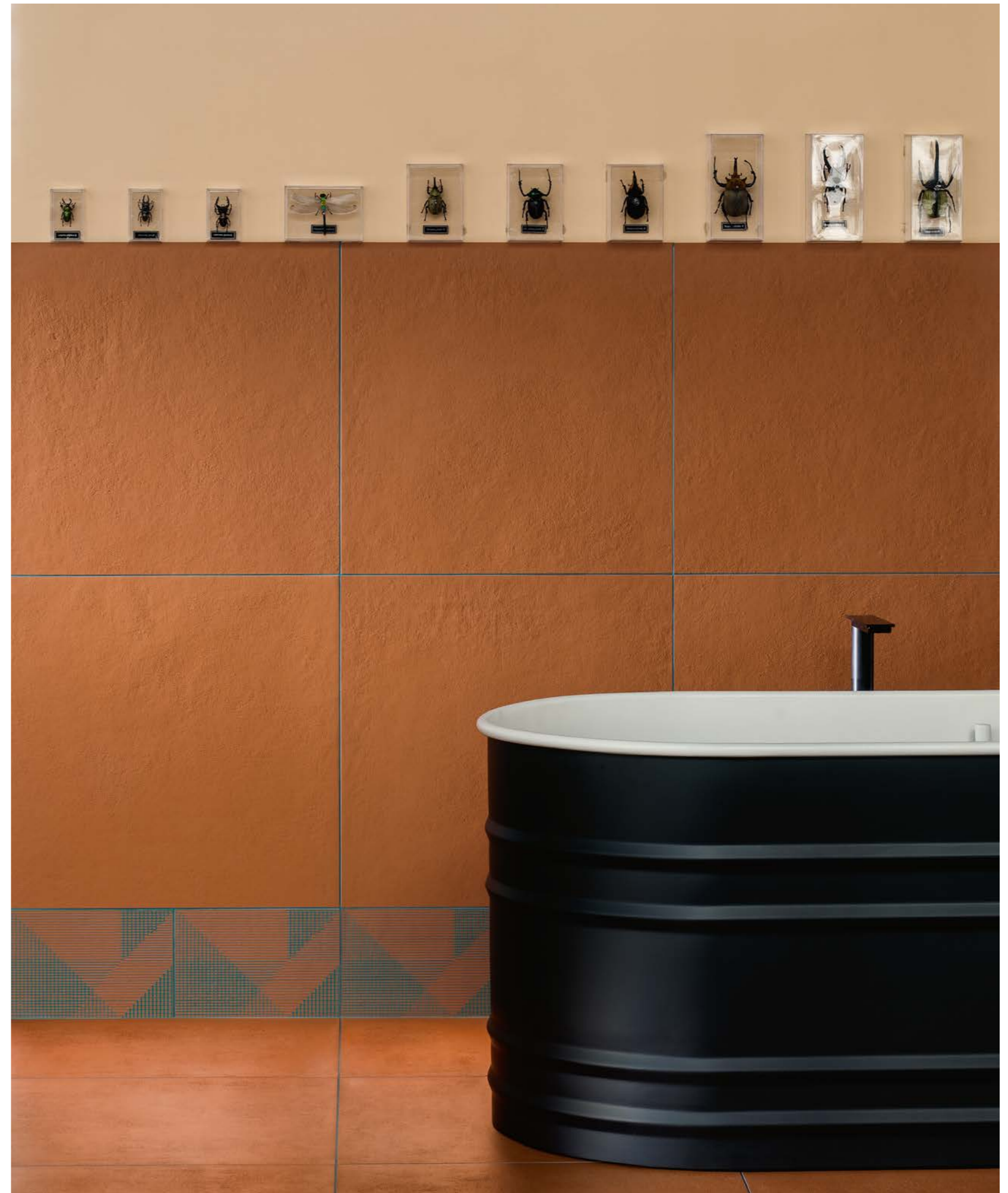



3D ELEMENTS

3D Elements	Bloc	Ronan & Erwan Bouroullec	300
	Brac	Nathalie Du Pasquier	308
	Celosia	Patricia Urquiola	314
	Hives	Konstantin Grcic	320
	Mistral	Edward Barber & Jay Osgerby	326
	Renga	Vincent Van Duysen	330

Bloc

Ronan & Erwan Bouroullec

Bloc è un mattone in terracotta prodotto secondo la tecnica artigianale di trafilatura. Si tratta di un elemento tridimensionale pensato per la costruzione di strutture architettoniche e decorative. Oltre alla versione Natural, è stata sviluppata una palette di quattro colori – Pearl, Blue, Red e Grey – declinati nelle finiture Matt e Glossy. Gli elementi smaltati opachi utilizzano alcune pitture della linea Mutina Accents, mentre quelli lucidi prevedono l'applicazione e la cottura di uno smalto ceramico brillante e trasparente. I buchi che contraddistinguono i moduli di Bloc possono essere lasciati vuoti per creare vibranti giochi di luce o riempiti con Tube, un accessorio in legno disponibile in rosso e blu.

Bloc is a terracotta brick produced with the artisanship extrusion process. It's a three-dimensional element conceived to build architectural and decorative structures. It features a Natural version and a palette of four shades – Pearl, Blue, Red and Grey – declined in both Matt and Glossy finishes. The glazed matt modules are obtained by using some paints from Mutina Accents, while the glossed ones came about from the application of a bright transparent ceramic glaze. The holes that characterise the elements of Bloc can be left empty, creating vibrant plays of light, or filled with Tube, a wooden accessory available in red and blue.





Bloc Pearl Glossy
Opposite page – Bloc Natural
Next page – Bloc Natural

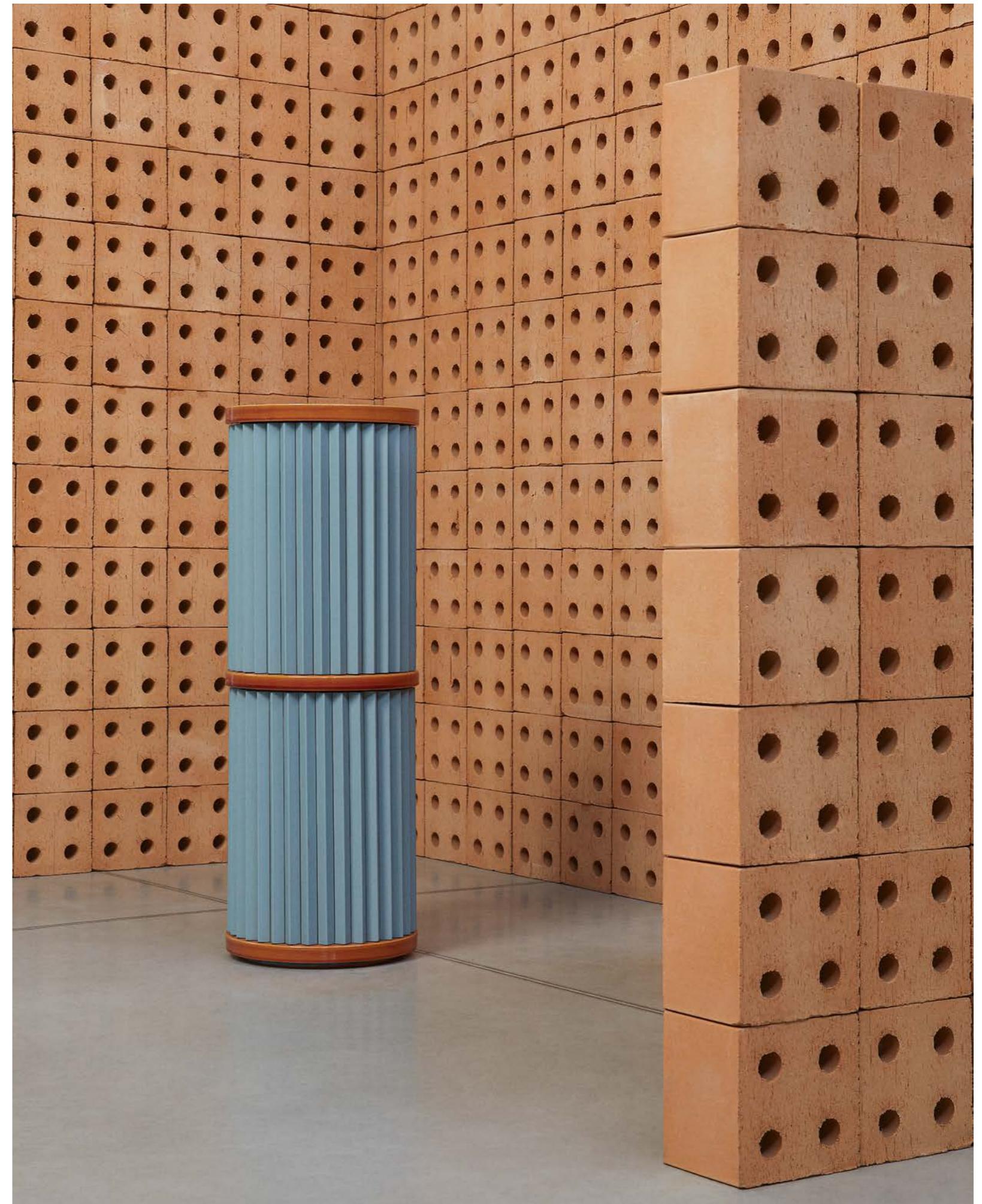



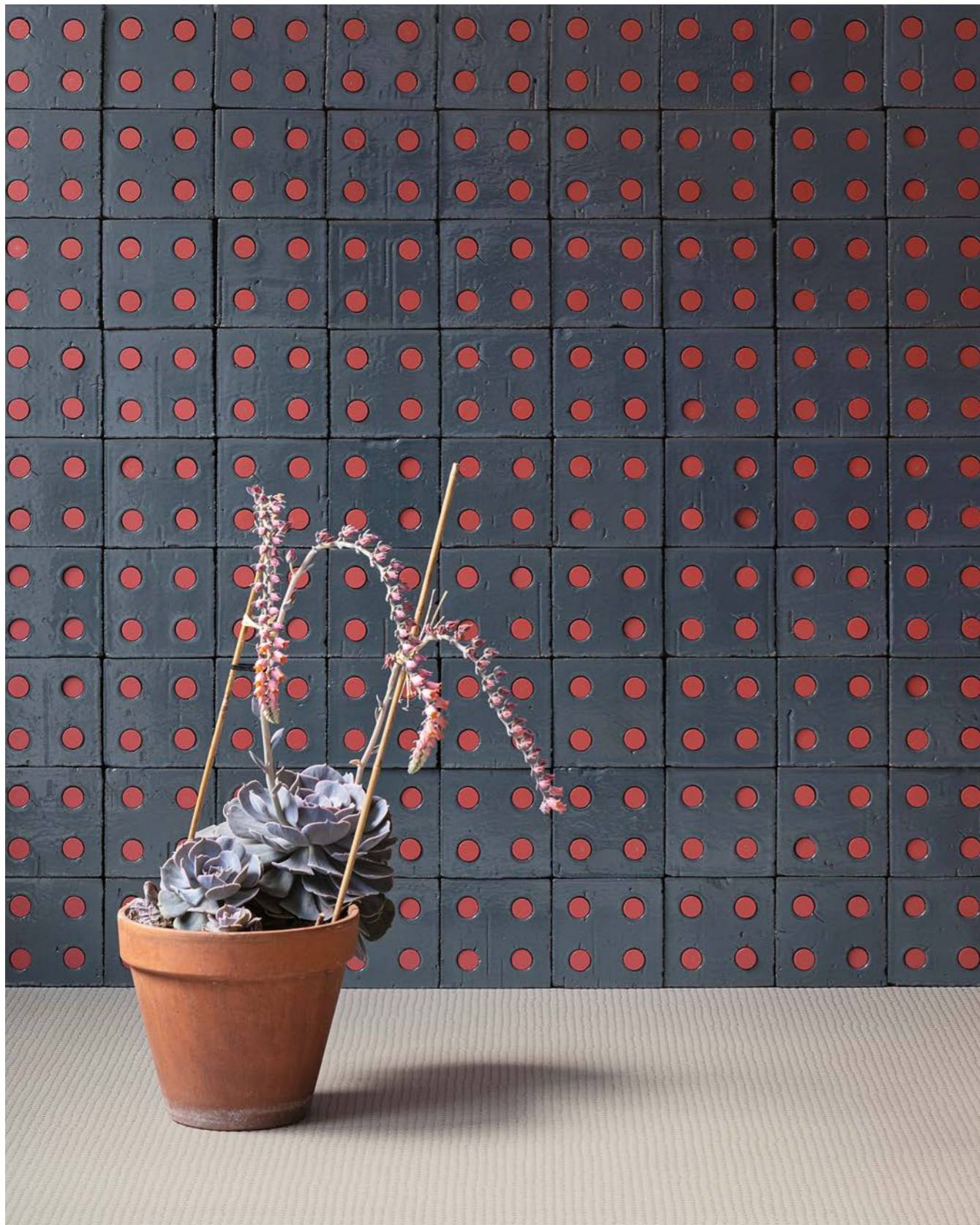

Brac

Nathalie Du Pasquier

Brac consiste in un elemento tridimensionale di dimensioni 12,5x22x10 cm, da immaginare come versatile componente per la creazione di strutture e pareti di ogni tipo, su cui prendono vita inaspettati giochi di luce e ombra. Realizzati in terracotta trafilata, i mattoni della collezione sono veri e propri elementi di design che possono essere installati sia verticalmente che orizzontalmente, all'interno di ambienti domestici o pubblici.

Brac presenta cinque varianti colore: Argilla, con superficie naturale matt, Bianco, Salvia, Marrone e Nero, dalla finitura smaltata lucida. Come in tutte le opere di Nathalie Du Pasquier, anche da questa collezione emerge un senso di giocosa spiritualità, risultato della sua imprevedibile capacità di connettere emozionalmente luce, colore e suono all'interno dello spazio.

Brac consists of a three-dimensional element in the size of 12,5x22x10 cm, imagined as versatile component for the creation of all sorts of structures and walls, where unexpected interplays of light and shadow come alive. Realised in extruded terracotta, the bricks that characterise the collection are real design elements that can be installed both vertically and horizontally, in residential and public interiors. Brac has a range of five colours: Argilla, with a natural matt surface, Bianco, Salvia, Marrone and Nero, with a bright glazed finish. As in all Nathalie Du Pasquier's artworks, also from this collection a sense of playful spirituality emerges, outcome of her unpredictable ability to emotionally connect light, colour and sound.







Brac Argilla, Bianco
Opposite page – Brac Argilla, Salvia

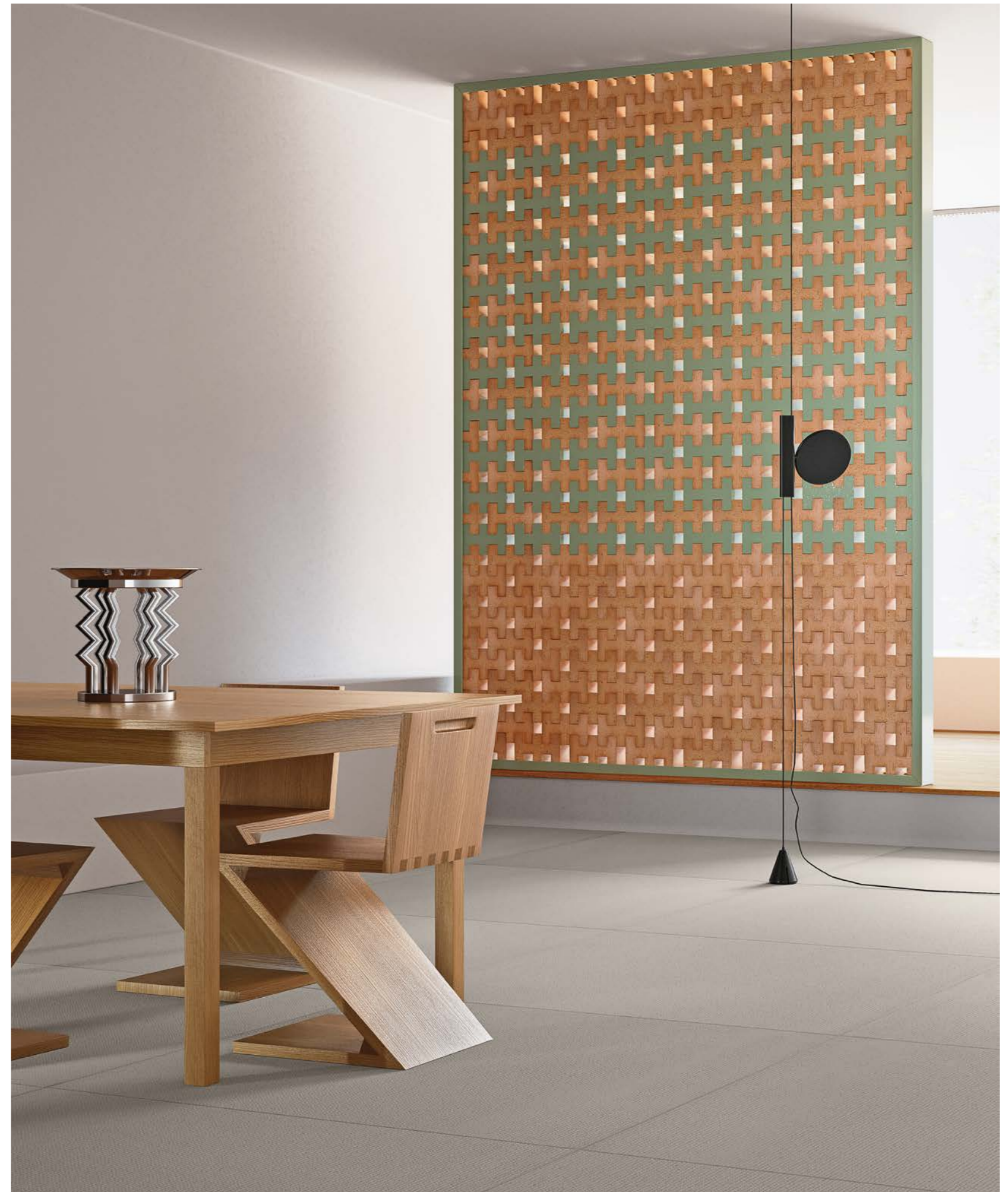

Celosia

Patricia Urquiola

Celosia riprende le tecniche di produzione artigianali proprie della terracotta al fine di ricreare elementi che emergono dalla terra, imperfetti e materici, segnati dalla mano dell'uomo e dal passare del tempo. Tegole, mattoni, mattoni forati e gelosie vengono smontati, destrutturati e reinterpretati in chiave moderna, conservando l'anima tradizionale che li caratterizza attraverso la produzione artigianale. Nascono così nuovi elementi di design in formato 20,5x26,5x10 cm, che consentono infinite soluzioni applicative sia in interno che in esterno. Celosia rappresenta il desiderio innovatore di uscire dalla bidimensionalità tipica del rivestimento murario, che qui viene tradotto nella sperimentazione della tridimensionalità del laterizio. Le sue forme e composizioni rievocano il sistema di numerazione romano, e la sequenza con cui vengono posati gli elementi crea filtri dinamici e unici.

Celosia is a new take on the artisanal production process typical of terracotta with the aim of giving birth to imperfect and tactile elements that come from earth, marked by the hand of man and time passing by. Roof tiles, bricks, hollow bricks and partition walls are undone, unstructured and re-interpreted in a new way, keeping the traditional touch given by the handcrafted production. New design elements are thus created, in the 20,5x26,5x10 cm nominal size, allowing limitless solutions for indoors and outdoors. Celosia represents the wish to explore out of the two-dimensional spaces typical of standard wall covering, which is translated into the experimentation of three-dimensional bricks. Shapes and compositions recall the Roman numbering system, and the sequence in which the elements are laid creates dynamic and unique designs.



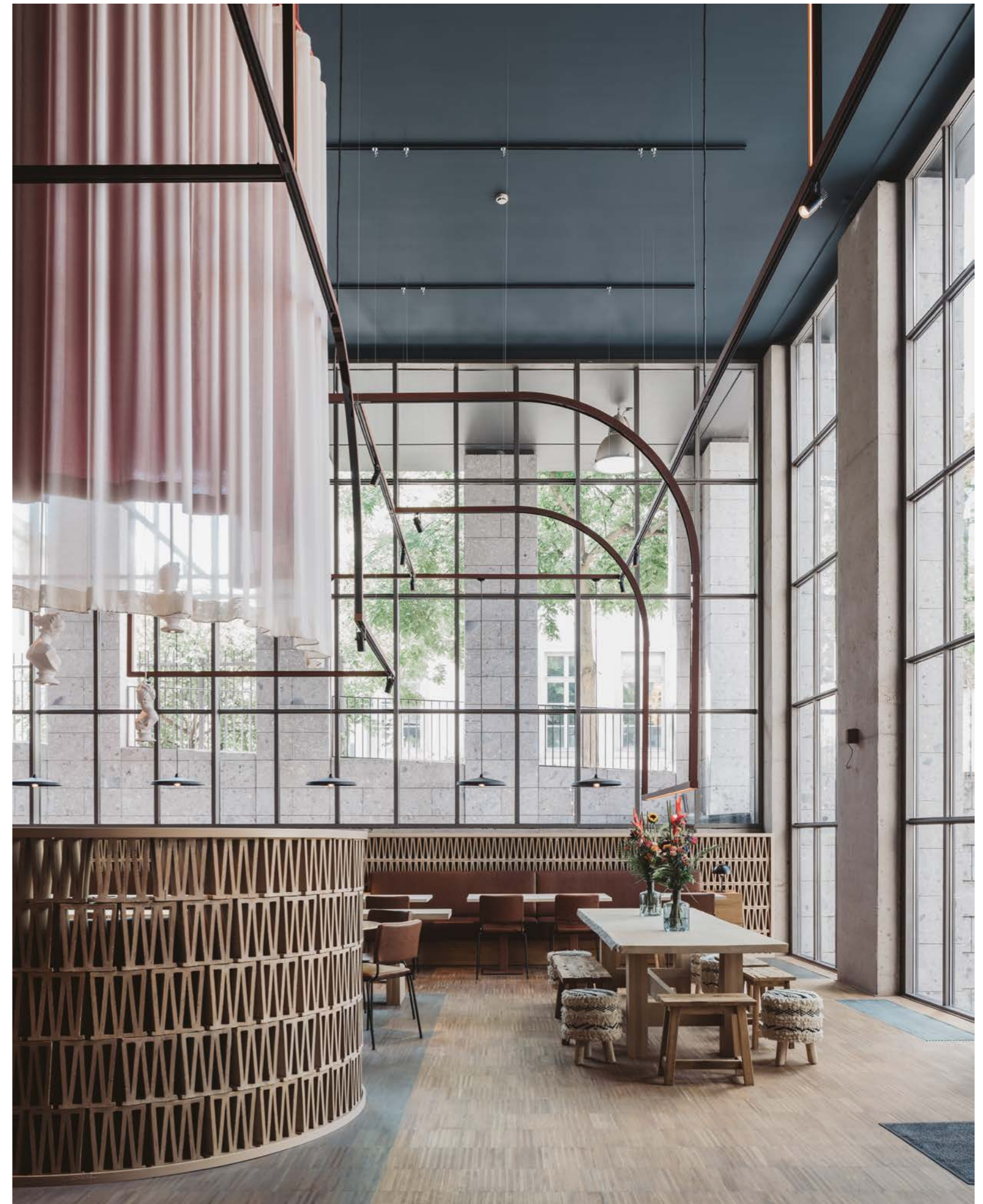

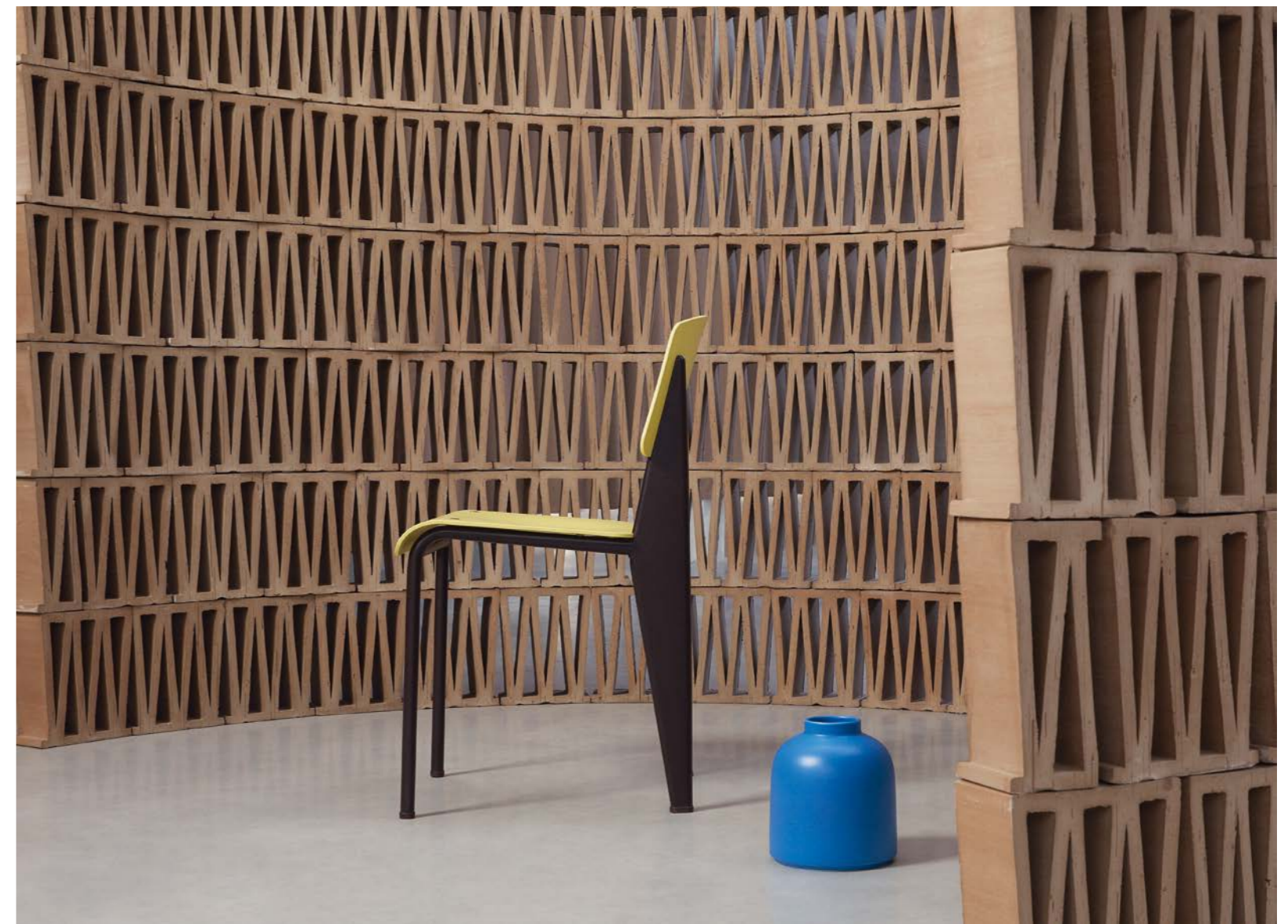

Hives

Konstantin Grcic

Hives si compone di un unico modulo: un mattone di forma esagonale, realizzato in terracotta – materiale antico di cui conserva colore, texture e proprietà – secondo la tecnica artigianale della trafilatura. Nel progettare questo modulo, Konstantin Grcic si è ispirato agli alveari, le costruzioni più efficienti presenti in natura, nonché potenzialmente espandibili fino all'infinito. Il risultato è un elemento 3D funzionale e dalla geometria organica, disponibile in un singolo formato che misura 13x22,5x7 cm. Hives può essere utilizzato sia in interno che in esterno, purché coperto, posato in diversi modi per creare soluzioni dall'aspetto contemporaneo e innovativo. I mattoni possono essere installati sia dal lato verticale, per dare vita a divisori, che in orizzontale. Posizionati in questo modo, allineati o sfalsati, consentono di ottenere pareti curve per la costruzione di elementi architettonici e pezzi d'arredamento, come colonne, banconi o piedi di tavoli.

Hives features one single module: an hexagonal brick hand-crafted in extruded terracotta, an ancient material of which it preserves colour, texture and properties. Konstantin Grcic drew inspiration for this element from beehives, the most efficient structures found in nature, almost infinitely expandable. The result is a functional 3D element with an organically geometry, available in the size 13x22,5x7 cm. Hives can be used both indoor and outdoor, so long as under cover, placing the elements in different positions in order to create contemporary and innovative aesthetic solutions. The bricks can be installed both in upright orientation, to build dividing walls, and in flat orientation. In this way, they can be placed laid flush with each other or in a staggered arrangement, giving birth to curved walls for the construction of architectural elements and furniture, such as columns, counters and table legs.







Mistral

Edward Barber & Jay Osgerby

Con Mistral, Mutina prosegue la sua ricerca sugli elementi tridimensionali. La collezione è nata da una reminiscenza delle architetture antiche tipiche della campagna italiana, da cui i designer hanno tratto ispirazione per progettare elementi estremamente innovativi e altamente funzionali. Mistral si compone di un unico modulo in terracotta smaltata prodotto artigianalmente per colaggio, disponibile nelle misure 12,5x25,5x12,5 cm. Le basi dell'elemento sono multiple all'altezza, a simboleggiarne la versatilità e le diverse combinazioni possibili – orizzontale e verticale, chiusa e aperta – grazie alle quali è possibile creare vibranti chiaroscuri lungo intere superfici, adatti ricoprire strutture architettoniche sia in interni che in esterni.

With Mistral, Mutina continues its research on three-dimensional elements. The collection was born from a reminiscence of the ancient architecture typical of the Italian countryside, from which the designers drew inspiration to design extremely innovative and highly functional elements. Mistral is composed of a single glazed terracotta module handcrafted for casting, available in 12,5x25,5x12,5 cm sizes. The bases of the Mistral elements are multiple to the height, to symbolize the versatility and the different possible combinations – horizontal and vertical, closed and open – thanks to which it is possible to create vibrant chiaroscuro along entire surfaces, suitable to cover architectural structures both indoors and outdoors.





Mistral Black
Opposite page – Mistral Black



Renga Vincent Van Duysen

Renga – termine utilizzato nella cultura giapponese per indicare una forma di poesia tradizionale composta da un'alternanza di strofe lunghe e corte, che letteralmente si traduce come *poesia a catena* – è il nuovo elemento tridimensionale progettato da Vincent Van Duysen per Mutina, concepito come un mattone per creare pareti divisorie, ma anche come oggetto architettonico. La collezione propone un singolo modulo in terracotta smaltata di dimensioni 15x25x15 cm. Ispirato alla muratura, una componente fondamentale del lavoro di Van Duysen, Renga presenta un design fortemente architettonico: un parallelepipedo verticale a base quadrata, rivestito agli angoli da quattro cilindri che conferiscono un aspetto d'insieme più dolce e morbido. Renga viene realizzato con la tecnica del colaggio, con un impasto di grès colorato, in modo da ottenere una superficie molto materica e opaca. In questo modo, ogni pezzo è unico e caratterizzato da sfumature sempre leggermente diverse. È disponibile nelle colorazioni Ivory, Brown e Grey.

Renga – a term used in Japanese culture to indicate a traditional form of poetry characterised by the alternation of long and short stanzas that can be literally translated as *chain poetry* – is the new three-dimensional element designed by Vincent Van Duysen for Mutina, conceived as a brick with which to create partition walls, but also as a decorative object in its own right. The collection features one single glazed terracotta element in a 15x25x15 cm format. Inspired by masonry, a fundamental aspect of Van Duysen's work, Renga has a strongly architectural design: a vertical parallelepiped with a square base, the four corners of which are covered by four cylinders that create softer overall appearance. Renga is produced with the casting technique, using a coloured liquid stoneware mixture so as to obtain a very tactile and matt surface. In this way, each piece is unique and characterised by always slightly different hues. It is available in three shades: Ivory, Brown and Grey.



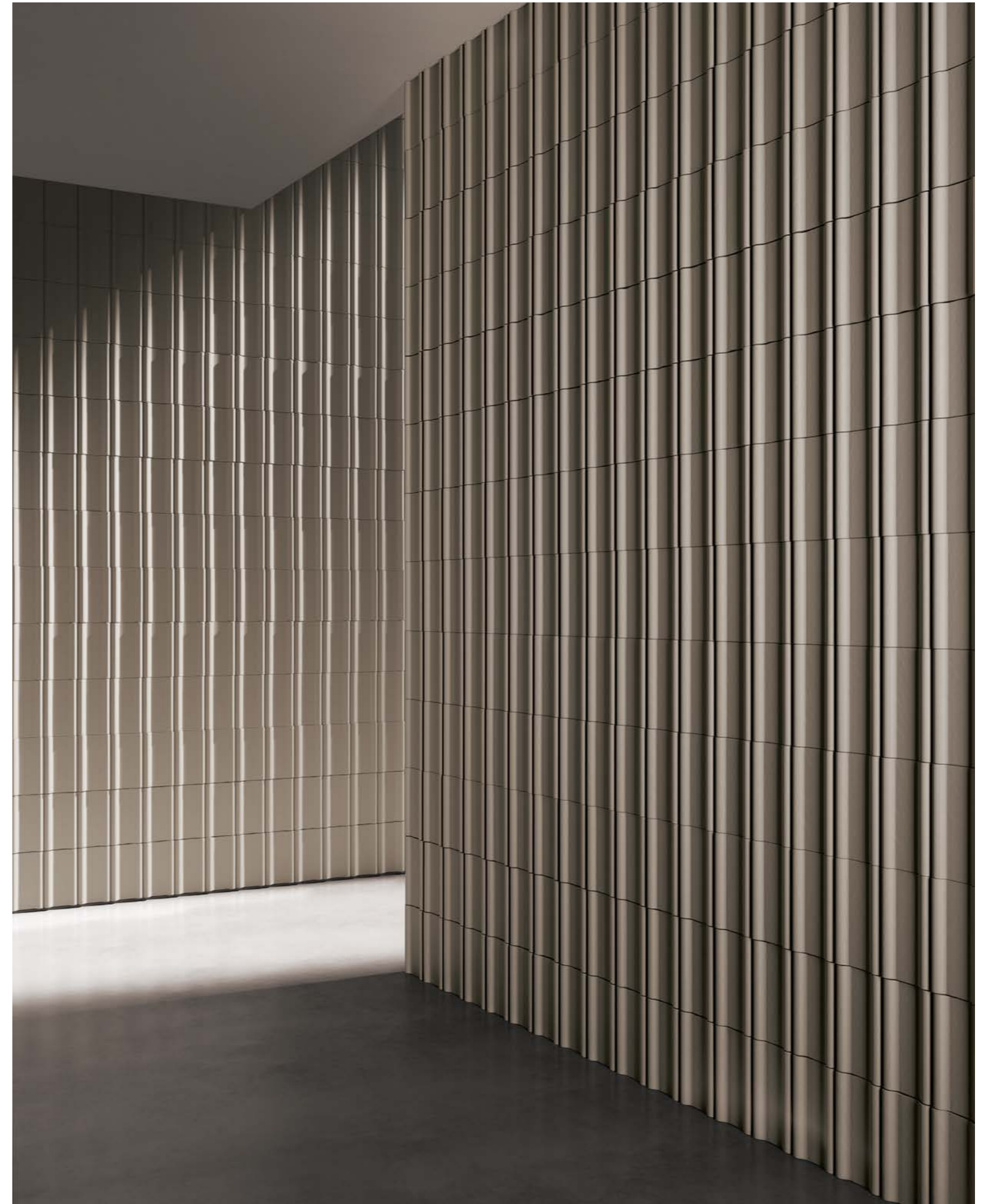

EDITIONS

Editions	El Lobo	Patricia Urquiola	338
	Paesaggi	Nathalie Du Pasquier	344
	Phenomenon Plate	Tokujiin Yoshioka	350
	Rombini Vases	Ronan & Erwan Bouroullec	354
	Yama	Vincent Van Duysen	360

El Lobo

Patricia Urquiola

El Lobo nasce da un gesto intuitivo di Patricia Urquiola: un unico tratto continuo, che ha tracciato il profilo di un lupo che ulula alla luna, libero e selvaggio. Un animale dalla forte simbologia, espressione di vitalità, istinto e natura, che la designer ha identificato con quelli che sono lo spirito e il percorso di Mutina. Proprio attraverso la ceramica dell'azienda, il disegno abbozzato da Patricia Urquiola si è trasformato in un oggetto di design inedito, pensato per la decorazione di interni, che entra a far parte del progetto Mutina Edition. El Lobo prende vita da quattro bande in ceramica smaltata lucida, nei colori Whisky e Nero, che vanno a delineare il profilo dell'animale in modo volutamente essenziale. La produzione artigianale consente di valorizzare a pieno la materia utilizzata, oltre a garantire l'alta qualità del prodotto finale e la sua unicità.

El Lobo is the result of the intuition of Patricia Urquiola: a single continuous line that traces the profile of a wild and free wolf howling at the moon. It's a strongly symbolic animal, an expression of vitality, instinct and nature, characteristics which the designer has associated with Mutina's own spirit and creative journey. Through the company's ceramics, in fact, Patricia Urquiola's sketch has been transformed into an exclusive design object, conceived for interior decoration and forming part of the Mutina Edition project. El Lobo comes to life as the result of four glazed ceramic bands, in the Whisky and Nero shades, creating the profile of the animal in an intentionally essential way. The artisan production makes it possible to fully enhance the material used, besides guaranteeing the high quality of the final product and its uniqueness.

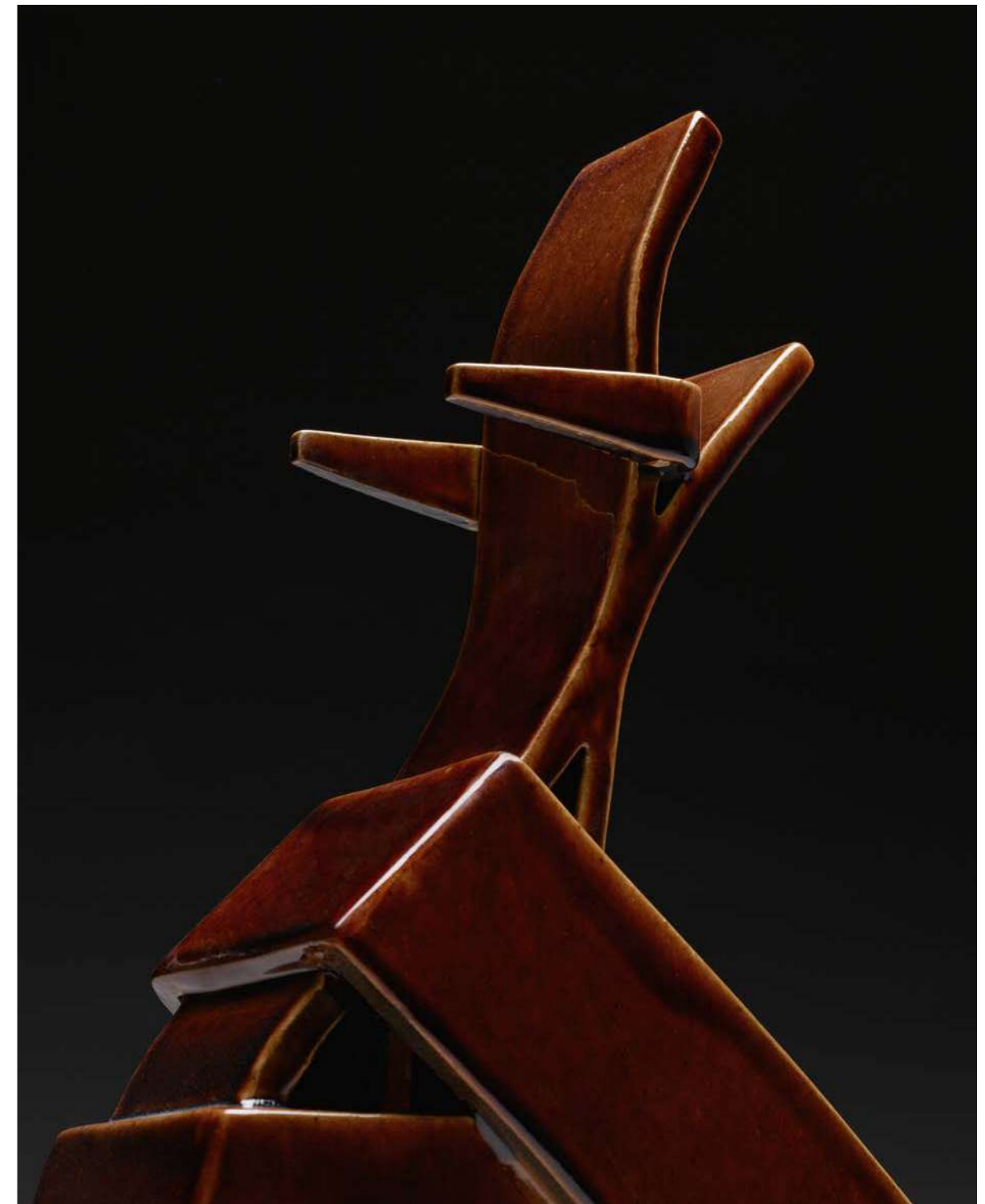





El Lobo nero
Opposite page – El Lobo whisky

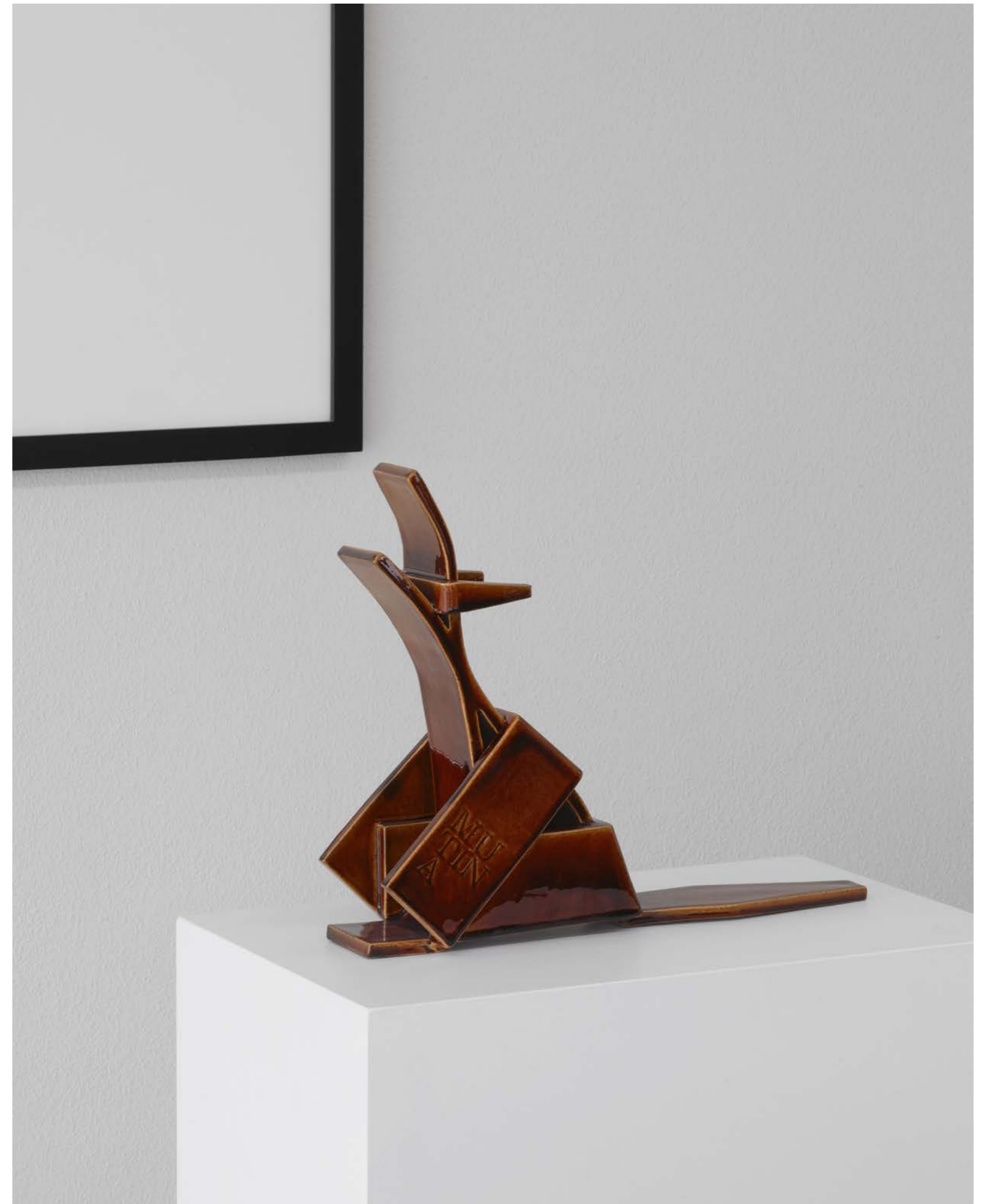

Paesaggi Nathalie Du Pasquier

Paesaggi propone una gamma di oggetti artistici pensati per la decorazione d'interni: tre modelli declinati in tre proposte colore con finitura smaltata lucida, per un totale di 9 pezzi unici. Gli elementi sono formati da una base alta 10 cm – quadrata nelle misure 40x40 cm, rettangolare nelle misure 40x60 cm e tonda con un diametro di 40 cm –, su cui prende vita una composizione di forme geometriche, declinate in una palette dai colori intensi – nero, bianco, verde, rosso, giallo e rosa –, utilizzati singolarmente nelle varianti in tinta unita o abbinati tra loro in quelle policrome. I manufatti di Paesaggi sono prodotti in collaborazione con Bitossi, realizzati con la tecnica del colaggio manuale, rifiniti e smaltati con il metodo della tuffatura. È un progetto che rispecchia la visione e l'approccio creativo di Nathalie Du Pasquier: le silhouette architettoniche giocano con le proporzioni e danno vita a dei paesaggi in miniatura, quasi metafisici, che trasportano l'osservatore in una dimensione sospesa nello spazio e nel tempo.

Paesaggi provides a range of artistic objects designed for interior decoration: three models declined in three colour options with a glossy finish, for a total of 9 unique pieces. The elements are composed of a 10 cm thick base – squared in the size 40x40 cm, rectangular in the size 40x60 cm and rounded with a diameter of 40 cm – on which a composition of geometric shapes comes to life. These components present rich hues – black, white, green, red, yellow and pink –, used individually for the variants in solid colour or combined with each other in the polychrome ones. The ceramic artifacts are produced in collaboration with Bitossi, realised by manual casting, refined and enameled with the "tuffatura" technique. The project reflects Nathalie Du Pasquier's vision and creative approach: the architectural silhouettes play with proportions, giving birth to miniature, almost metaphysical landscapes that bring the observer into a dimension suspended in space and time.

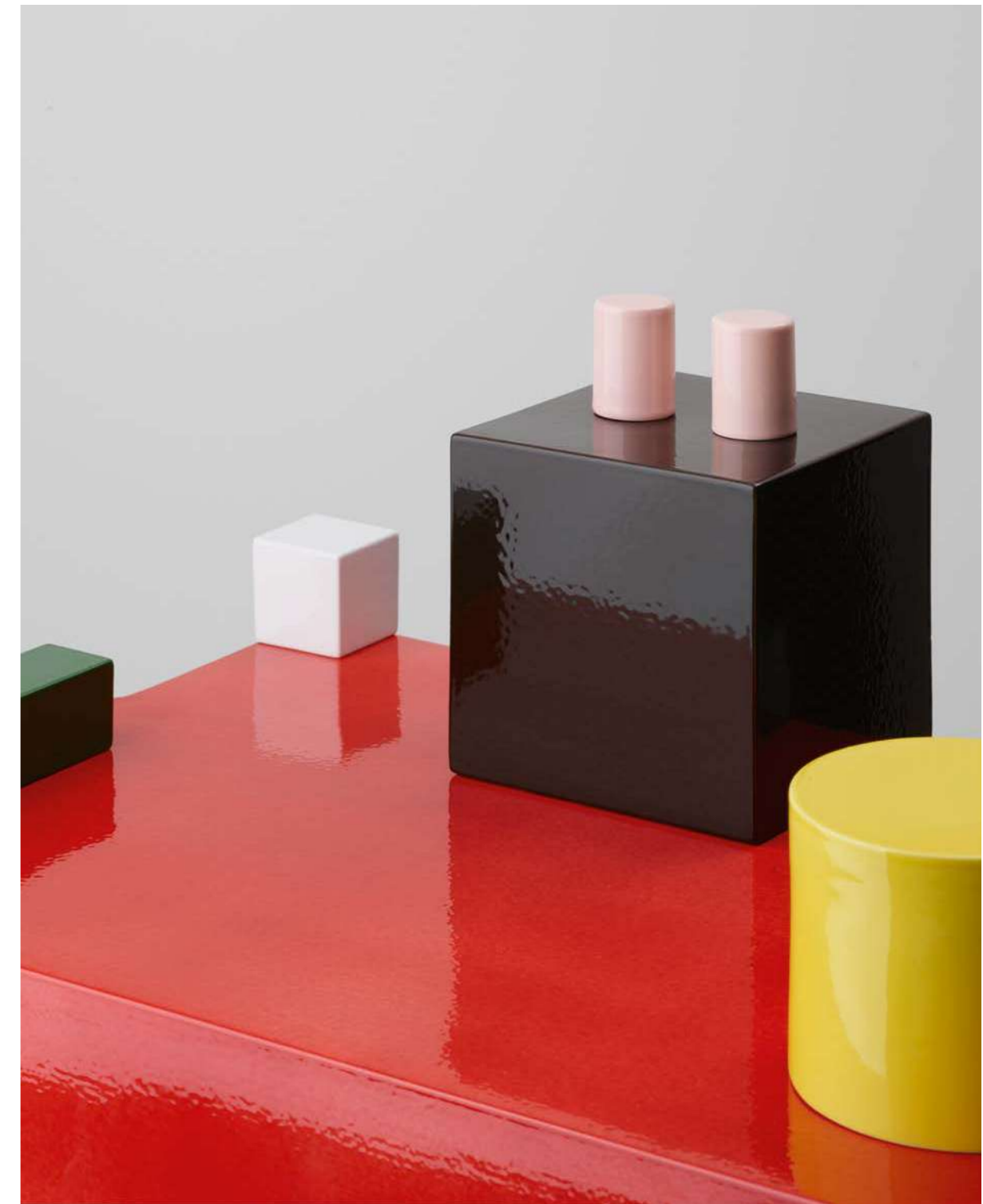





Phenomenon Plate

Tokujiin Yoshioka

Phenomenon Plate è la nuova Mutina Edition progettata da Tokujiin Yoshioka. Come suggerisce il nome, si tratta di un'evoluzione di Phenomenon, la prima collezione realizzata dal designer giapponese per Mutina nel 2010. Il progetto, infatti, sfrutta il modulo Honeycomb per creare un oggetto di design dalla superficie irregolare e fortemente decorativa, che richiama forme e texture presenti nel mondo della natura, da sempre grande fonte di ispirazione per Tokujiin. Phenomenon Plate viene realizzato in grès smaltato, spargendo in maniera casuale i tasselli di ceramica all'interno di uno stampo rotondo per poi pressarli manualmente. Questo processo consente di ottenere un risultato finale sempre diverso e irripetibile, dove l'imperfezione diventa un valore aggiunto estetico e formale. Ogni prodotto è un pezzo unico e prezioso, che viene consegnato timbrato e numerato, espressione dello spirito creativo del designer unito all'artigianalità italiana.

Phenomenon Plate is the new Mutina Edition designed by Tokujiin Yoshioka. As the name suggests, it is an evolution of Phenomenon, the first Mutina collection developed by the Japanese designer in 2010. The project, in fact, uses the Honeycomb module to create a design object with an irregular and incredibly decorative surface that recalls shapes and textures from the natural world, which has always been a great source of inspiration for Tokujiin. Phenomenon Plate is produced in glazed porcelain stoneware by spreading ceramic pieces randomly inside a circular mold and then pressing them by hand. This process creates an always different and unrepeatable end result, where imperfection becomes an aesthetic and formal added value. Each product is a precious, unique piece which is delivered stamped and numbered, denoting the designer's creative spirit combined with Italian craftsmanship.



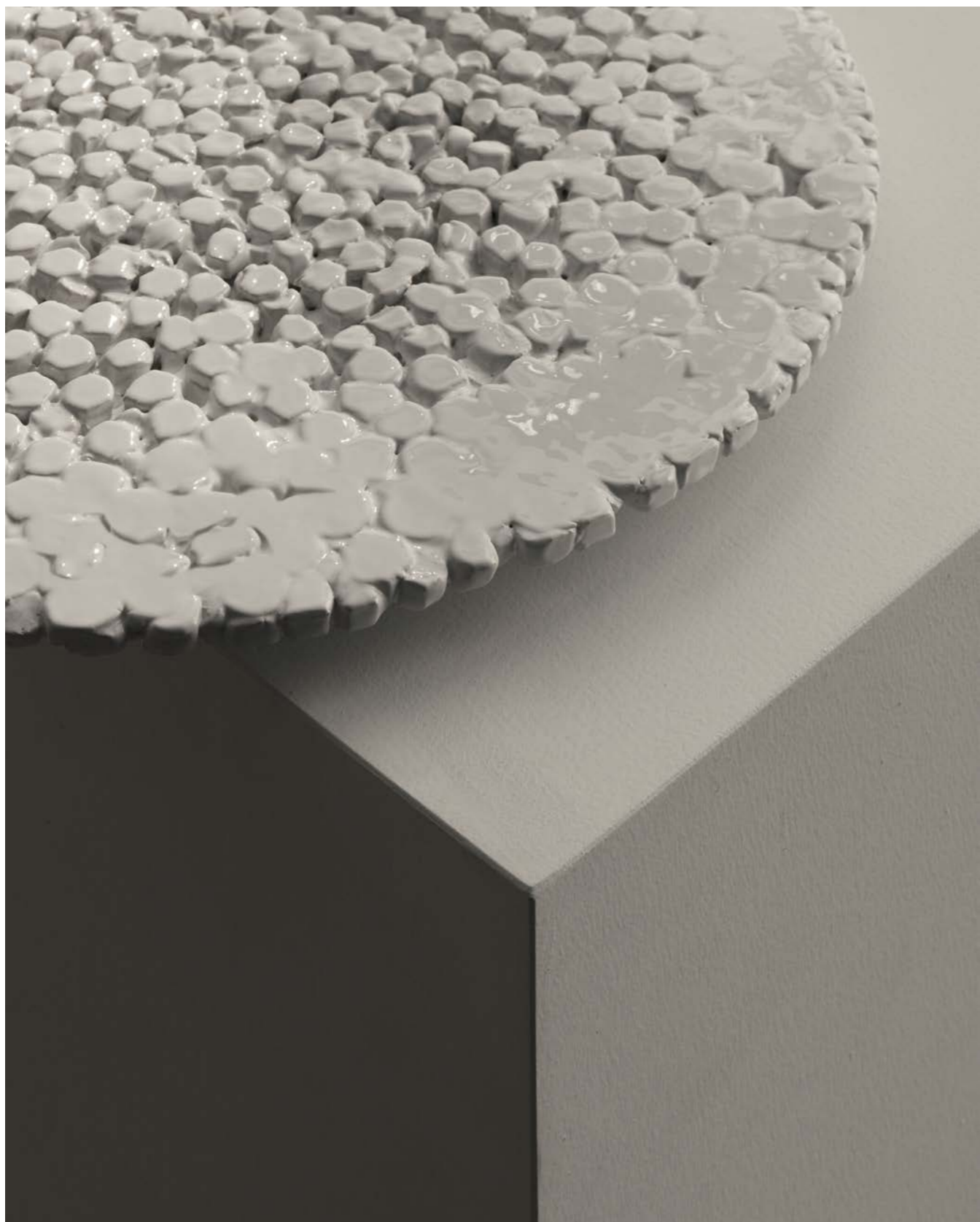

Rombini Vases

Ronan & Erwan Bouroullec

Con Rombini Vases, Mutina aggiunge un nuovo, importante tassello alle collaborazioni portate avanti nel mondo degli interni d'autore. I vasi in ceramica, progettati dai designer Ronan ed Erwan Bouroullec e prodotti in collaborazione con Bitossi, sono pensati per accompagnare le collezioni del brand e fornire nuovi stimoli per la decorazione d'interni. Rombini Vases propone tre tipologie di vasi – Vase A nelle misure 37 (H) cm x 16,3 (Ø), Vase B nelle misure 71,2 (H) cm x 24,8 (Ø) e Vase C nelle misure 71,2 (H) cm x 24,8 (Ø) – realizzati interamente a mano secondo la tecnica del tornio. Gli elementi che li compongono (cilindro, base e anello) sono stati modellati con precisione dai maestri artigiani, assemblati, verniciati e passati a una doppia fase di cottura, per poi venire rifiniti applicando uno ad uno i listelli di Rombini Triangle Extra Small.

With Rombini Vases, Mutina adds a new, significant collaboration within the world of auteur interiors. The ceramic vases, designed by Ronan and Erwan Bouroullec and produced in collaboration with Bitossi, are made to be paired with the collections of the brand as well as providing new stimuli for interior decoration. Rombini Vases offers three variants – Vase A in the size 37 (H) cm x 16,3 (Ø), Vase B in the size 71,2 (H) cm x 24,8 (Ø) and Vase C 71,2 (H) cm x 24,8 (Ø) – that are entirely handcrafted with the use of a lathe. The elements of the vase (cylinder, base and ring) have been manufactured with precision by master artisans, assembled, varnished and cooked two times. In the end, they are refined by applying the Rombini Triangle Extra Small strips one by one.

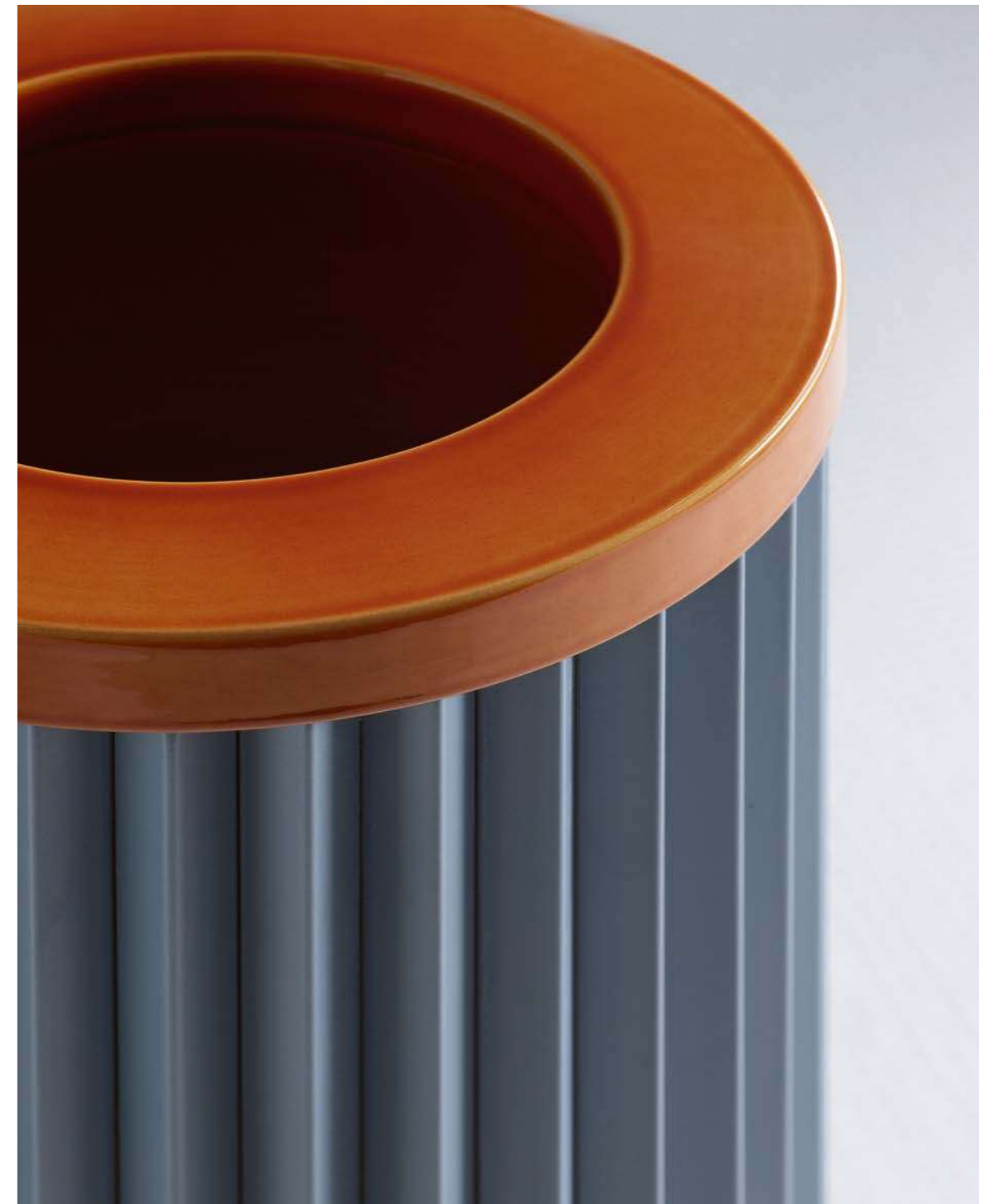





Opposite page – Rombini Vase C Glossy Brun-Rose-Vert
Rombini Vase A Glossy Vert-Rose



Yama Vincent Van Duysen

In giapponese, yama significa montagna. Così Vincent Van Duysen chiama il nuovo progetto che entra a far parte di Mutina Editions, un'ode alla potenza della natura e alla sua forza trasformatrice. L'architetto si è ispirato ai ciottoli che, trascinati dalla corrente dei fiumi che scorrono dalle vette degli altipiani fino alla valle, vengono modellati rivelando forme morbide e sensuali. Yama lavora sul concetto di riduzione, riproducendo l'effetto di una pietra che viene tagliata dall'uomo in diverse fasi, in omaggio al lavoro del designer e scultore Isamu Noguchi. La collezione viene realizzata in grès con la tecnica del colaggio manuale, ottenendo un range di cinque oggetti di design – Yama A nelle misure 18x18 cm, Yama B nelle misure 18x35 cm, Yama C, Yama D e Yama E nelle misure 35x35 cm – timbrati e numerati, che condividono il medesimo linguaggio, acquistabili singolarmente o come un set. Manufatti enigmatici, dalla forte presenza scultorea, decorativi nella loro semplicità rivelatrice.

In Japanese language, yama means mountain. This is how Vincent Van Duysen calls the new project forming part of Mutina Editions, an ode to the strength of nature and its transforming force. The architect has taken inspiration from the pebbles which, carried by the current of rivers flowing from the highland peaks to the valley, are shaped into soft, sensual shapes. Yama focuses on the concept of reduction, reproducing the effect of a stone cut by man in different phases, as an homage to the work of designer and sculptor Isamu Noguchi. The collection is made in porcelain stoneware with the manual casting technique, creating a range of five stamped and numbered design objects – Yama A in 18x18 cm format, Yama B in 18x35 cm format, Yama C, Yama D and Yama E in 35x35 cm format, offered singularly or as a set – that share the same language. They are enigmatic artifacts, with a strong sculptural presence, decorative in their revealing simplicity.

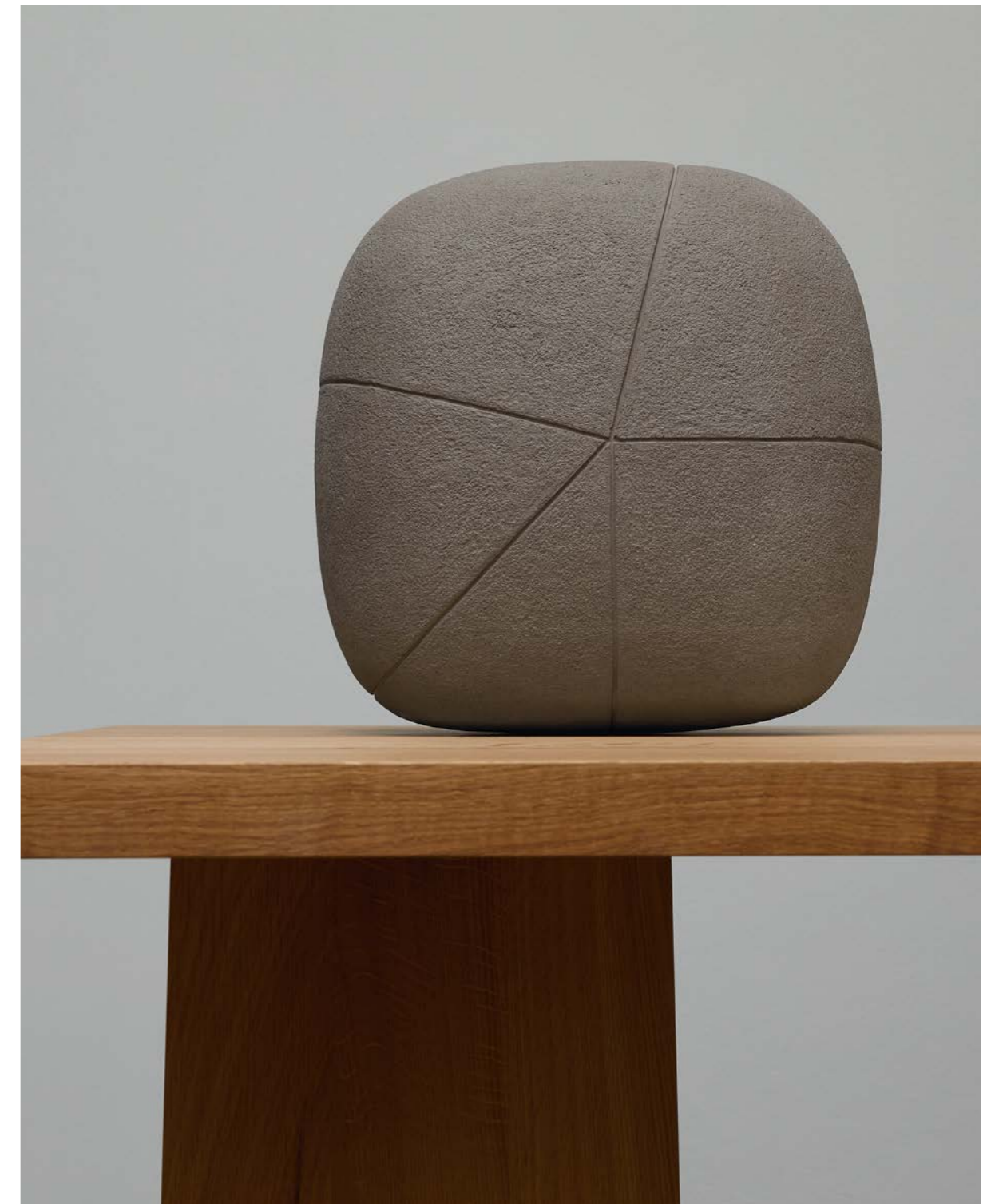

Next page – Yama A, B, C, D, E



PAINTS

Paints

Accents Paints
Margherita Paints

OEO Studio
Nathalie Du Pasquier

368
368

Paints

Index

367

Accents Paints OEO Studio

Margherita Paints Nathalie Du Pasquier



Accents comprende un'ampia gamma di pitture pensate appositamente per accompagnare i rivestimenti ceramici dell'azienda, sia in termini di palette che di finish. 25 proposte colore sono declinate nelle finiture Matt e Satin, 6 nella variante Limetouch.

Margherita Paints è la palette di pitture sviluppate appositamente da Nathalie Du Pasquier per la collezione Mattonelle Margherita. Un range di 5 colorazioni vivaci, disponibili nelle versioni Matt e Satin.

Accents features a wide range of paints especially developed to be paired with the ceramic tiles of the company, both in terms of palette and finish. 25 colours are declined in the variants Matt and Satin, 6 in the Limetouch finish.

Margherita Paints is the palette of colourings specifically developed by Nathalie Du Pasquier for the Mattonelle Margherita collection. It presents a range of 5 vibrant nuances, available in the finishes Matt and Satin.

Accents Paints – Matt / Satin



Chalk



Yarn



Sand



Ivory



Pearl



Pebbles



Limestone



Moss



Slate



Graphite



Iron



Coal



Mist



Pine



Arctic



Olive



Oxide



Earth



Terra



Clay

Accents Paints – Limetouch



Flour



Chalk



Limestone



Mountain



Coke



Moss

Margherita Paints – Matt / Satin



Giallo



Arancione



Rosa



Azzurro



Verde



Accents Paint Matt Graphite
Opposite page – Accents Paints Matt Earth

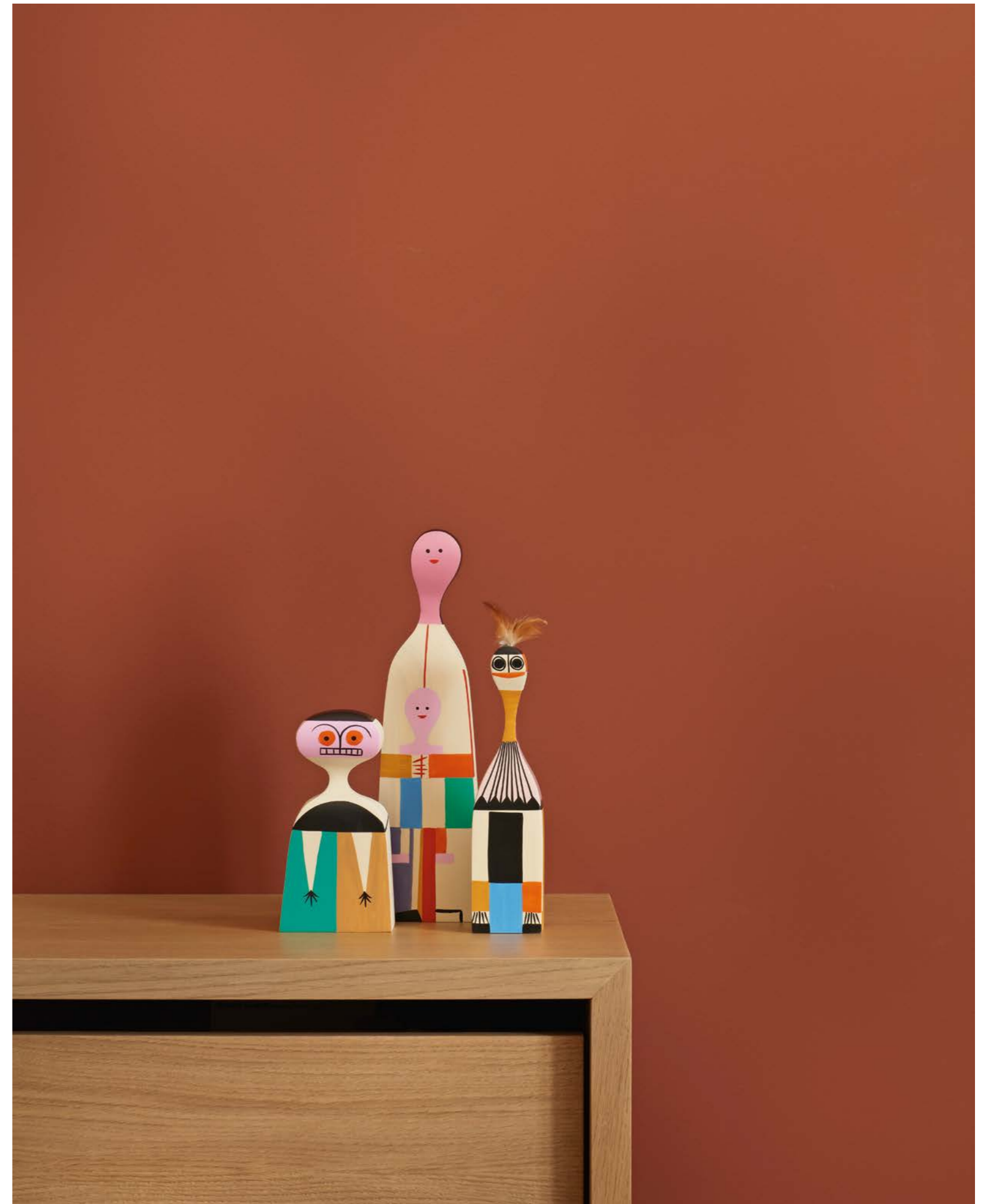



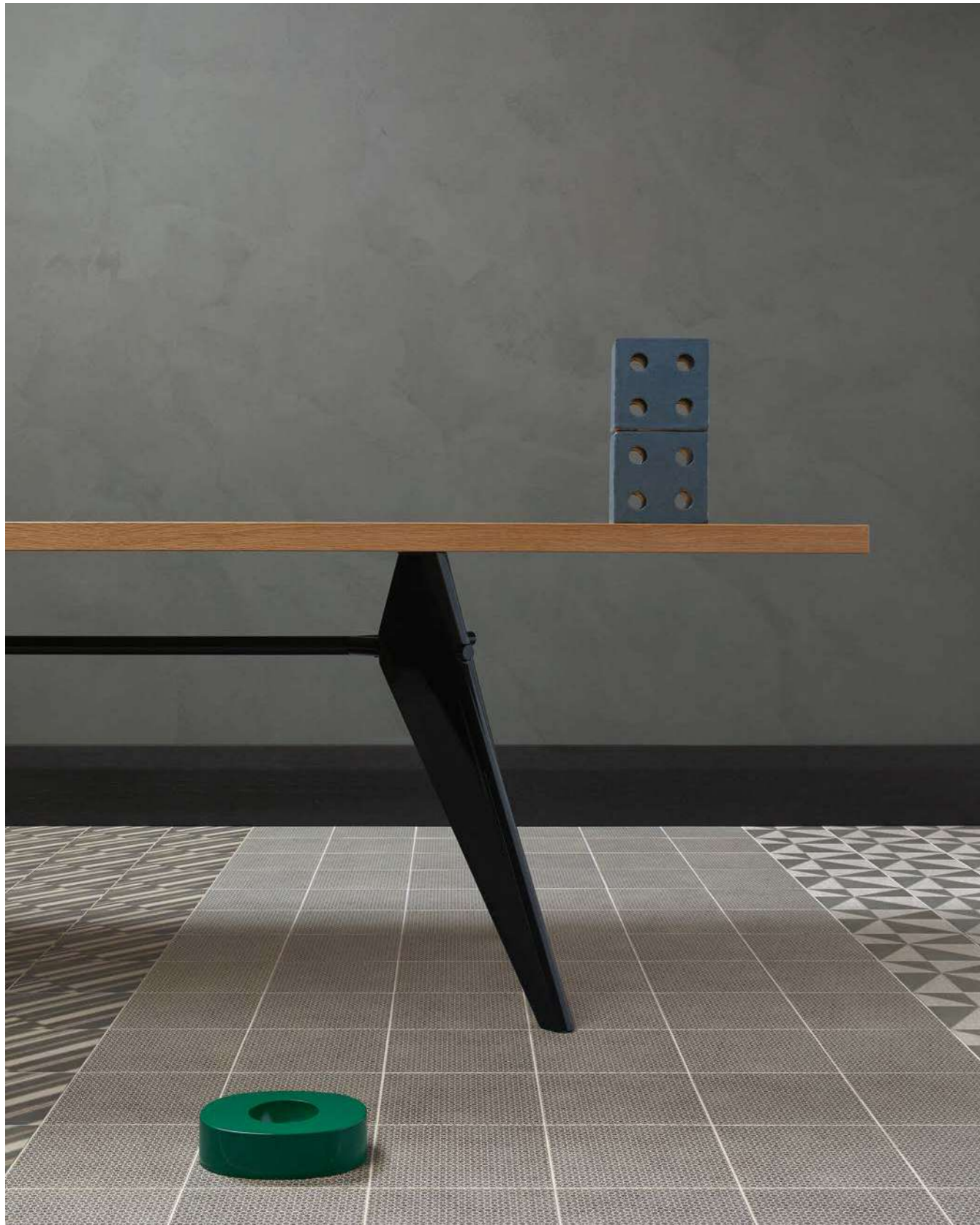

**WOOD
& METAL**

Wood & Metal

Accents Wood & Metal
Pico Bois

OEO Studio
Ronan & Erwan Bouroullec

382
390

Wood & Metal

Index

381

Accents Wood & Metal OEO Studio



Con Accents, Mutina e OEO Studio propongono una collezione di elementi che vedono protagonisti materiali come legno e metallo: battiscopa, boiserie ed elementi divisori, pensati per interagire con le superfici ceramiche del brand.

With Accents, Mutina and OEO Studio offer a collection of elements featuring materials such as wood and metal: panelling, skirtings and space-dividing elements, designed to interact with the ceramic surfaces of the brand.

Accents Metal



L Profile Horizontal



L Profile Corner

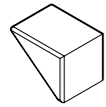

L Cap Horizontal

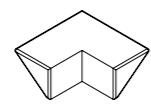

L Cap Corner

Accents Wood



Wall Panel Corner 100



Wall Panel Corner 160



Wall Panel Corner 100



Wall Panel Corner 160

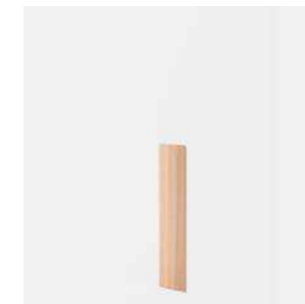

Wall Panel 100



Wall Panel 160



Wall Panel 100



Wall Panel 160

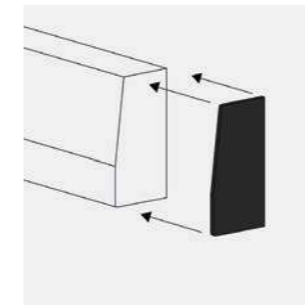

End piece S



Skirting S



Skirting S



End piece L



Skirting L



Skirting L

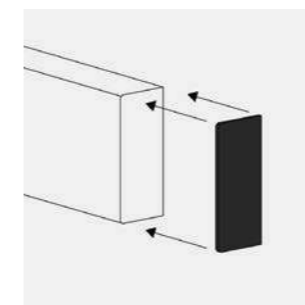

End Piece Rectangular



Rectangular Skirting



Rectangular Skirting



Accents Wood: Skirting L dark oak, Wall Panel 160 dark oak, Rectangular Skirting dark oak.

Opposite page – Accents Wood: Skirting S light oak, Wall Panel 100 light oak, Skirting L light oak, Rectangular Skirting light oak.

Next page – Accents Wood: Skirting L light Oak, Rectangular Skirting light oak, Skirting S light oak.

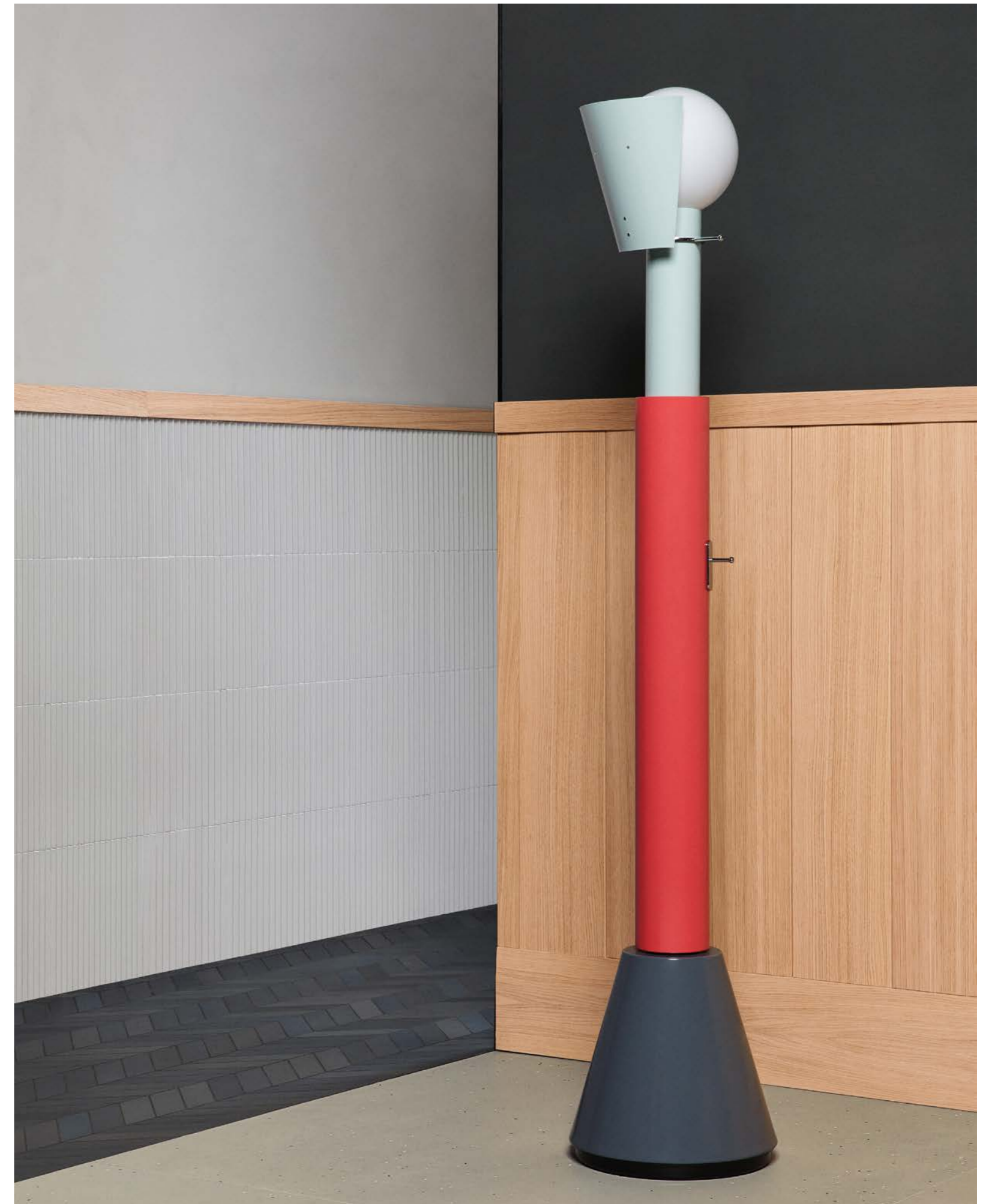



Pico Bois

Ronan & Erwan Bouroullec

Con Pico Bois, Mutina realizza per la prima volta un pavimento in legno. Un materiale caro a Ronan ed Erwan Bouroullec, spesso utilizzato nelle abitazioni della Bretagna per conferire un senso di calore agli interni. Come suggerisce il nome, si tratta di un'evoluzione di Pico – prima collezione realizzata dai designer e grande classico Mutina – di cui riprende il motivo grafico con puntini declinati nei colori blu e rosso, che anche qui vengono impressi nella materia per esaltare la texture naturale del legno. I listelli di Pico Bois sono realizzati in rovere europeo nelle dimensioni 7x49 cm, con uno spessore di 14 mm (4 mm di strato nobile e 10 mm di betulla per il supporto) e una microbisellatura che ne esalta le qualità, rendendo la posa più semplice. Il caratteristico pattern "a puntini" viene realizzato imprimendo e verniciando la superficie grezza con monocomponente a base d'acqua, un processo ecologico che garantisce la durabilità del prodotto, senza la necessità di interventi successivi alla posa. In ultimo, i listelli vengono trattati con un innovativo processo di bugnatura, per conferire al legno l'effetto "martellato" che contraddistingue la collezione Pico.

Pico Bois is the first wooden floor realised by Mutina. It's a dear material to Ronan and Erwan Bouroullec, as it is often used in Brittany-based houses to give a sense of warmth to interiors. As the name itself suggests, it's an evolution of Pico – the first collection realised by the designers and a great classic of Mutina – of which it recalls the graphic motif made of blue and red dots, impressed onto the surface so as to enhance the wood texture. Pico Bois slats are realised in European oak in the size 7x49 cm, with a thickness of 14 mm (4 mm of top layer and 10 mm of birch as a support) and a micro bevel that exalts its quality, making the installation easier. The typical dotted pattern is realised by impressing and glazing the surface with a water-based single-component, an ecological process that guarantees durability without the necessity of further interventions. Ultimately, the modules are rated with an innovative embossing process, recreating the "hammered" effect that distinguishes the Pico collection.



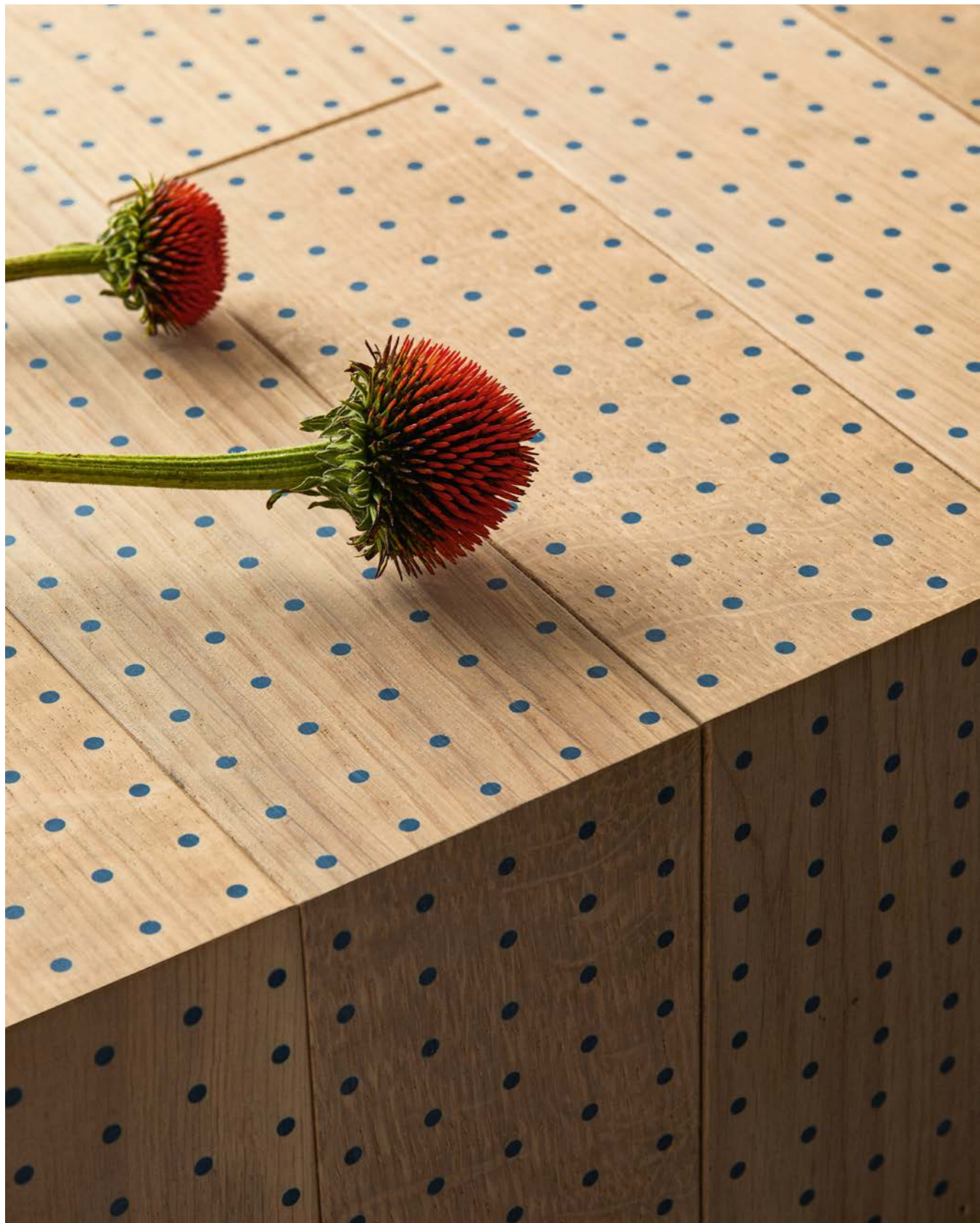

Pico Bois Blue Dots
Opposite page – Pico Bois Red Dots

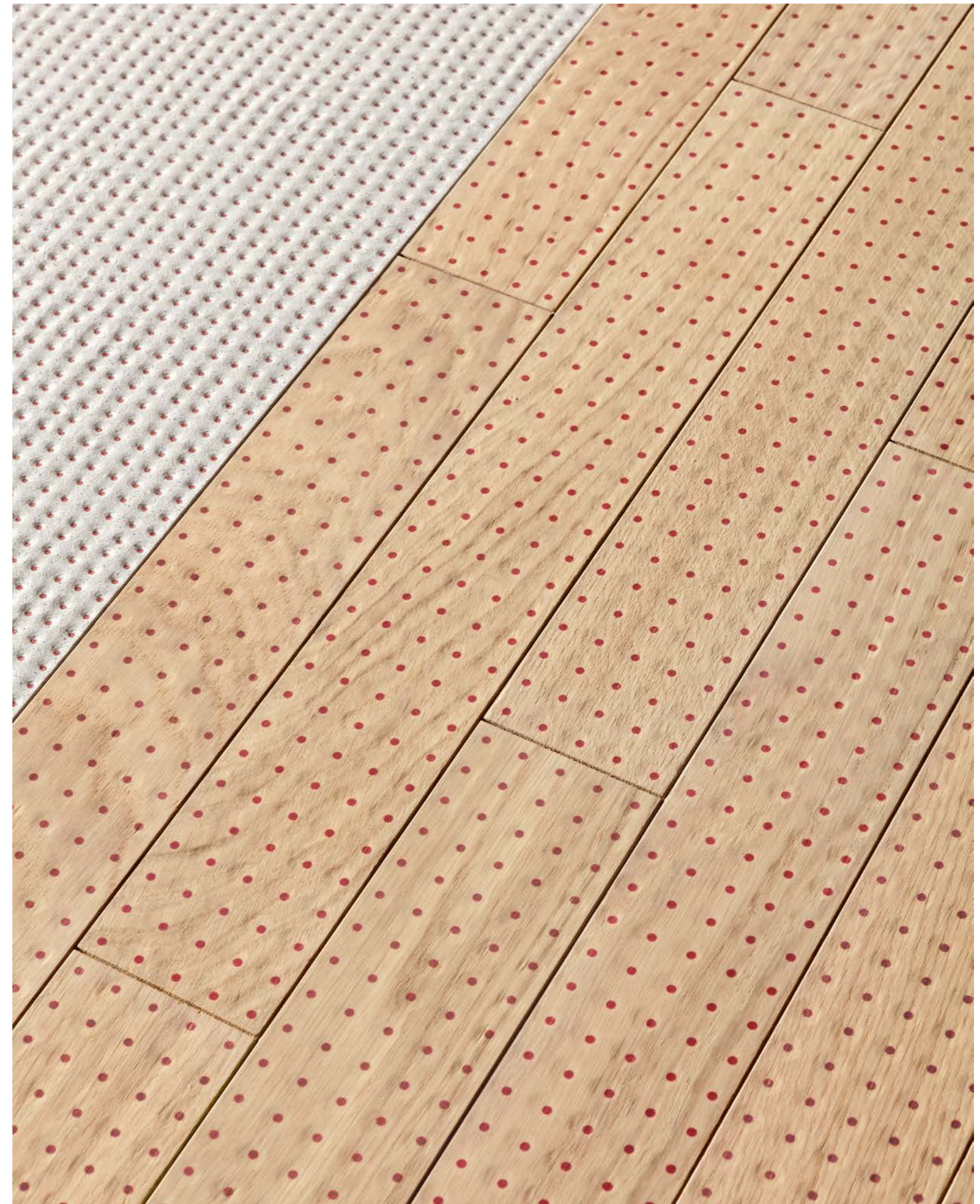

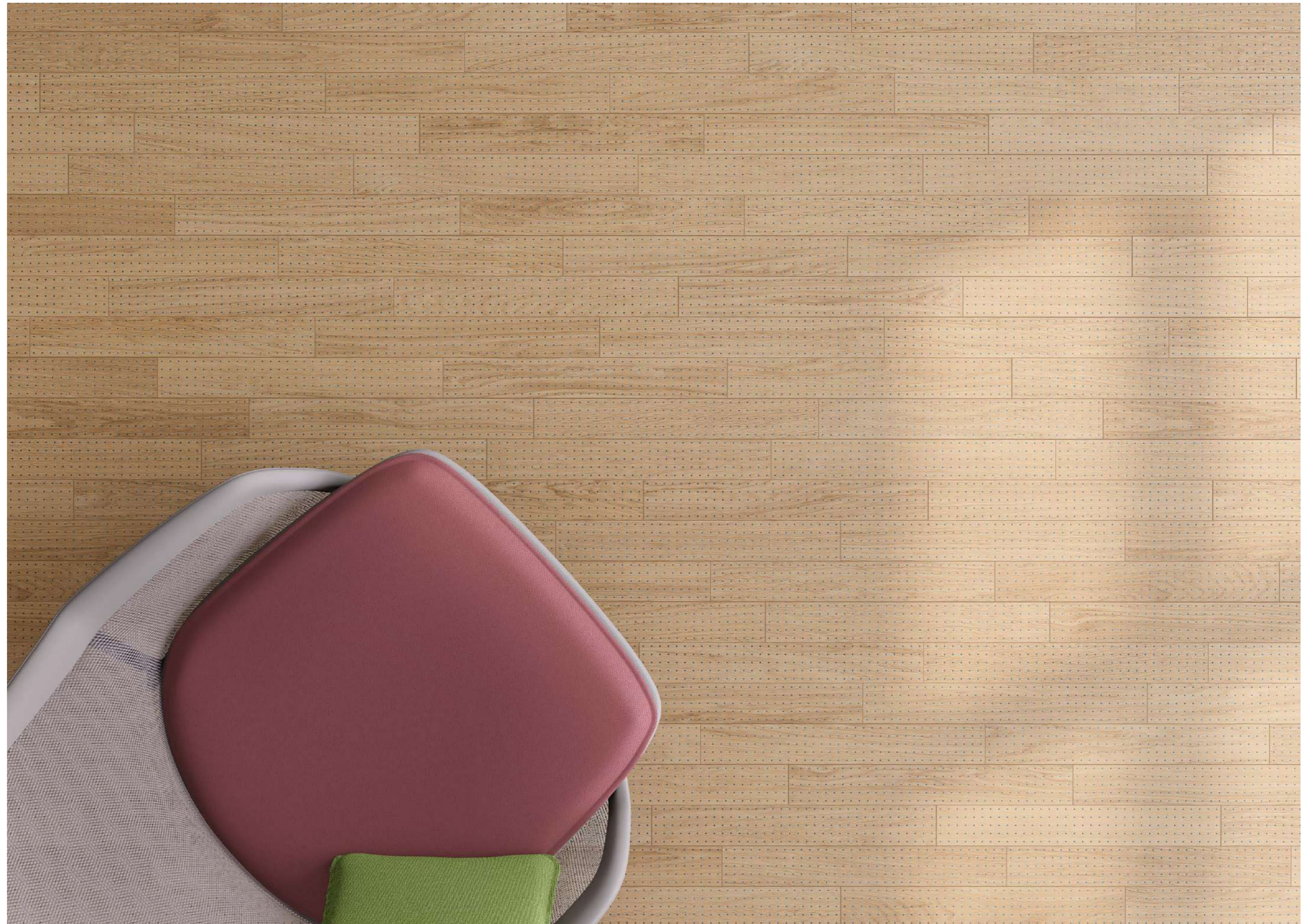

ACCESSORIES

Accents Accessories OEO Studio



La collezione Accents, progettata da OEO Studio per il progetto Mutina Interiors, propone un universo di prodotti complementari di alta qualità con l'obiettivo di ridefinire l'approccio al mondo dell'interior design. La gamma Accessories comprende cabinet e mensole, specchi, appendiabiti e portasciugamani, che accostano materiali come legno, metallo e pelle. Una selezione di 18 complementi d'arredo funzionali ed estremamente versatili, in armonia con lo spirito di Mutina.

The Accents collection, designed by OEO Studio for the Mutina Interiors project, provides a universe of high quality complementary products with the aim to redefine the approach to the world of interior design. The Accessories range feature cabinets and shelves, mirrors, racks and towel racks, that combine materials such as wood, metal and leather. A selection of 18 functional and extremely versatile furnishings, in line with Mutina's spirit.

Accents Accessories



Cabinet Large



Cabinet Large



Cabinet Small



Cabinet Small



Mirror Large



Mirror Large

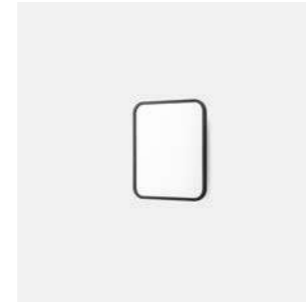

Mirror Small

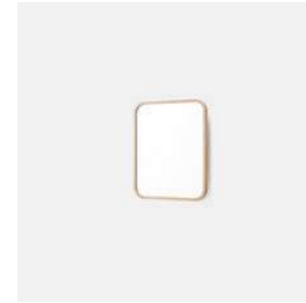

Mirror Small



Rack 72



Rack 72



Rack 192



Rack 192



Shelf Small



Shelf Small



Shelf Large



Shelf Large



Towel Rack Large

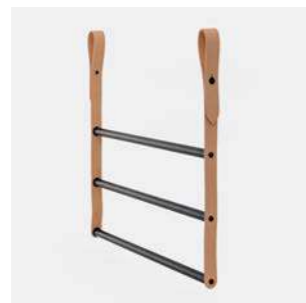

Towel Rack Tall

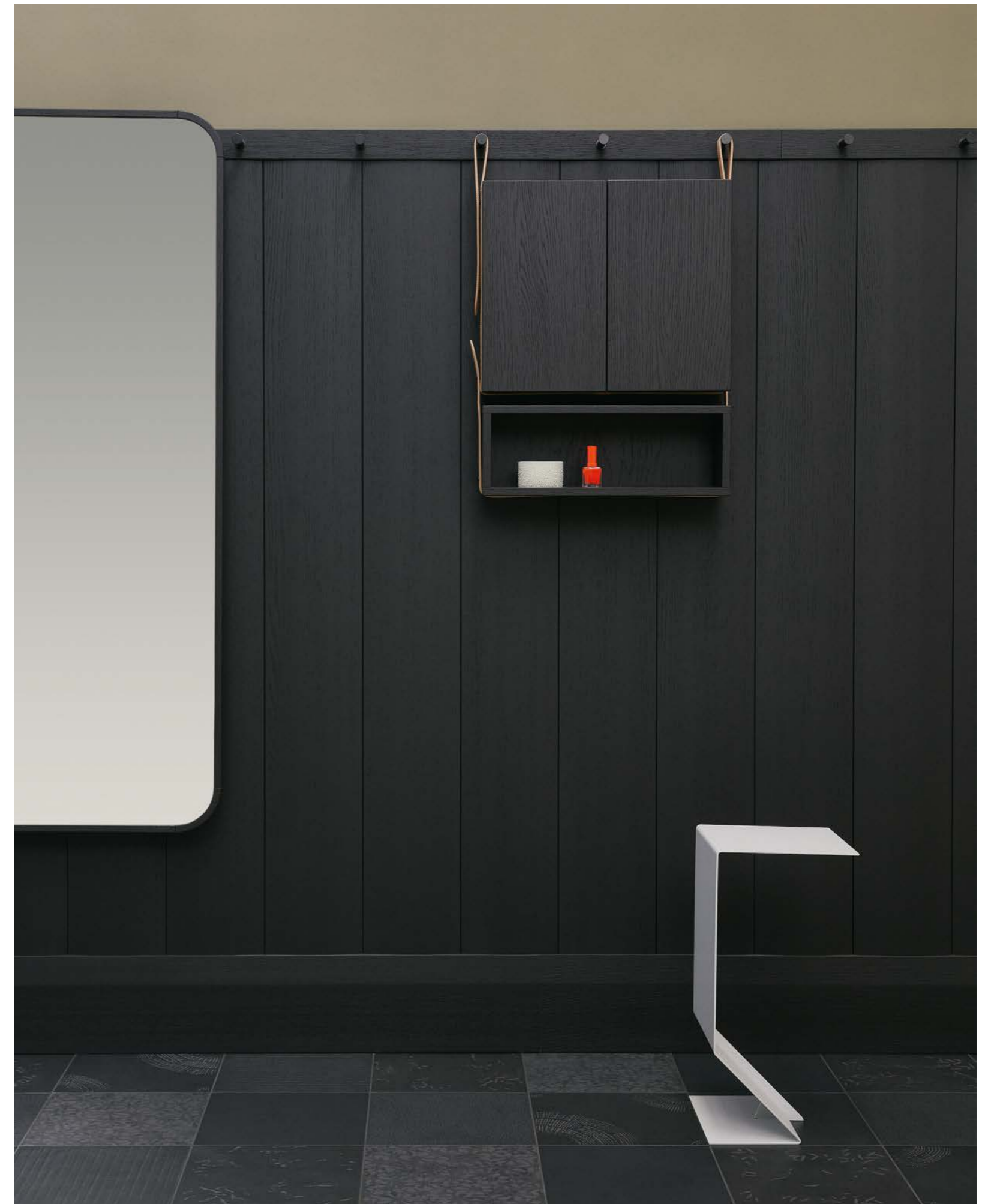

Accents Accessories: Rack 192 light oak, Mirror Small light oak



Previous page – Mirror Large dark oak, Cabinet Large dark oak, Cabinet Small dark oak
Accents Accessories: Rack 192 dark oak, Cabinet Large light oak, Towel Rack Large

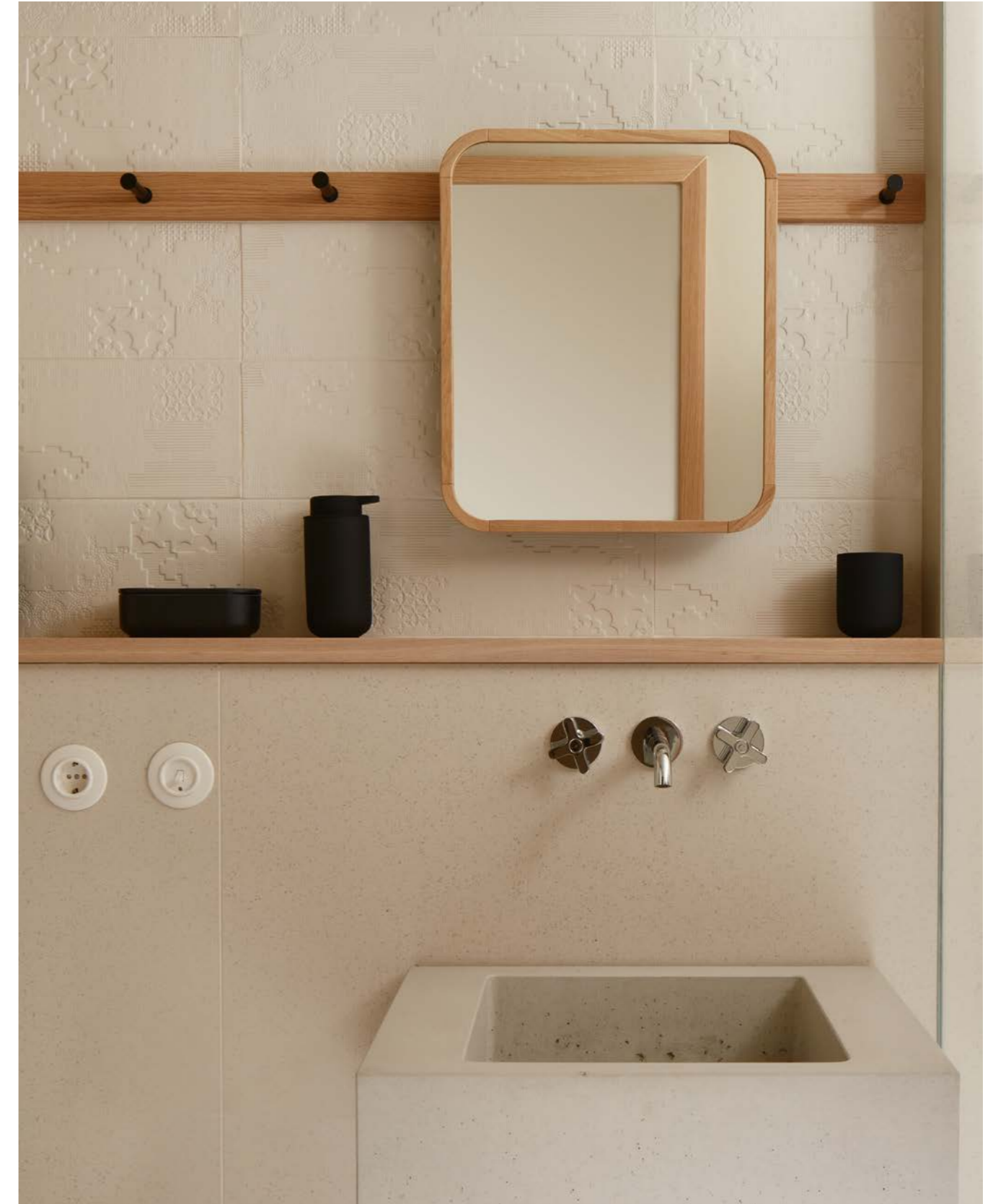

TECHNICAL FEATURES

TILES

Azulej

collection	Azulej
design	Patricia Urquiola, 2012
production	Industrial
material	Rectified porcelain stoneware with digital printing glazing
thickness	10 mm
nominal sizes	20-20 cm (8"-8")
specification	<ul style="list-style-type: none"> - 3 base colors: Bianco, Grigio, Nero. - 27 registered graphic patterns. - All the 27 different patterns are created to compose a combination, not individually on sale. - 9 individual patterns for each base color have been selected to be individually used. - Digital printing technology with 4 different textures layers on the tile's surface.
complementary pieces	Skirting
awards	Wallpaper Design Award 2013, Interior Innovation Award 2014
category	UNI EN 14411 App G (BIA group) GL

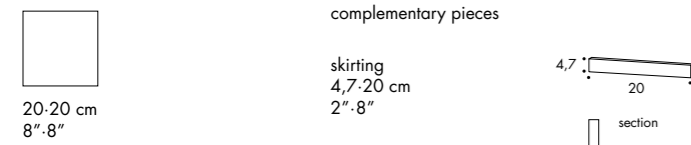

Laying and maintenance tips

use	Floor, wall – indoor, outdoor.
installation	For an even, smooth shading effect when laying, alternate material from several different boxes.
recommended adhesive	Adhesive for porcelain stoneware.
recommended joints	2mm joints. Use wedges to fix the caliber differences in work size between tiles.
recommended fillers	Cement-based grout/epoxy grout.
cleaning at the end of installation	<p>CEMENT-BASED GROUT: Buffered acid (e.g. DETERDEK PRO by FILA, or similar). Wet the floor with water, dilute the product 1:5 with water and pour it on the floor. Wait for 2 or 3 minutes then use a white scotch brite pad and rinse well with clean water.</p> <p>EPOXY GROUT: Alkaline detergent (e.g. FILA CR10 by FILA). FILA CR10: apply pure, wait for 30 minutes then use a green scotch brite pad.</p> <p>SILICONE: Solvent for silicone (e.g. FILA ZERO SIL.). Pour it straight onto the stain, wait for 20 minutes and remove the mark using scotch brite.</p> <p>PAINT: Can usually be removed using water, but if resin-based paints or particular enamels have been used, it is best to ask the manufacturer which solvent is most suitable.</p> <p>RUST: stain remover es. FILA NO RUST. Apply the product onto the stain, leave for 15 minutes, remove the residue and rinse thoroughly.</p>
general cleaning (installed tiles)	You are recommended to use ordinary neutral detergent diluted in water. Avoid using acid or alkaline products, waxes and/or impregnants. During ordinary cleaning it is recommended to use extremely abrasive items (such as scourers and iron or steel sponges) as little as possible. This recommendation must be adhered to rigorously in the case of tiles with a glossy surface finishing as they are more susceptible to the risk of scuffs, scratches and loss of shine, etc. In the event of heavy dirt or particularly textured surfaces, use an alkaline detergent and rinse after washing. For large surfaces, the use of a floor washing machine is recommended. During every-day cleaning procedures, it is necessary to remember that certain types of dirt (dust, sand) increase the abrasive effect of foot-traffic. Therefore we recommend that you avoid bringing in this type of dirt, which comes in from the outside, by placing a door-mat at the entrance.
calibers (real size)	196,3 mm x 196,3 mm



Scan the QR code to download the technical features in other languages

Colors

BIANCO



GRIGIO



NERO



For information about the available grouts, please contact the sales department.

Technical features

STANDARD	FEATURES	VALUE REQUIRED	AZULEJ
ISO 10545/3 ASTM C373	water absorption	< 0,5% < 0,5%	0,04% 0,04%
ISO 10545/4	breaking strength	Sp> 7,5 min 1300	resistant
EN 101	surface hardness (scala mohs)	> 5	6
ISO 10545/9 ASTM C484	resistance to thermal shock	no visible alteration no samples must show visible defects	resistant unaffected
ISO 10545/12 ASTM C1026	frost resistance	no visible alteration unaffected	resistant unaffected
ISO 10545/13 ASTM C650	resistance to chemical attacks	no visible alteration	resistant unaffected
ISO 10545/14	stains resistance	minimum 3	5
DIN 51130-04	slip resistance	medium values 6±10° R9 10±19° R10 19±27° R11 27±35° R12 > 35° R13	R9
DIN 51097		–	–
DCOF		> 0,42	0,62
B.C.R.		–	0,52
LEED CERTIFICATION 4.1			8,6% Bianco - 15,8% Grigio - 15,8% Nero
ENVIRONMENTAL MANAGEMENT SYSTEM ISO 14001 : 2004			
VOC EMISSION			available upon request
DECLARATION OF CONTENTS			available upon request
SDS			available upon request
EPD			available upon request
BPD3			available upon request
HPD			available upon request

Packing

SIZE	PCS-SQM	PCS-BOX	SQM-BOX	BOX-PAL	KG-BOX	KG-PAL	SQM-PAL
20-20 cm	25	24	0,96	72	20,95	1508,00	69,12
pattern 20-20 cm	25	24	0,96	72	20,95	1508,00	69,12
combination 20-20 cm	25	27	1,08	48	23,45	1126,00	51,84
skirting 4,7-20 cm	–	10	2,00 ml	–	2,15	–	–



Scan the QR code to download the technical features in other languages

Bas-Relief

collection	Bas-Relief
design	Patricia Urquiola, 2010
production	Artisanal
material	Porcelain clays artisanally extruded.
feature	Colours, shade and size variations are intrinsic properties of this hand made product. In order to make grouting easier, a protective silicone film has been applied on each piece. Remove it before the final cleansing.
thickness	9 mm
nominal sizes	PATCHWORK, GARLAND, CLOUD: 18-54 cm (7"-21") CODE: 26,5-18 cm (10,55"-7")
specification	– Handmade collection, manufactured by extrusion and hand cut. The theme of the bas-relief is proposed with several versions and depths. – Composed by 3 patterns just for walls in size 18-54 cm and by a floor base in the size 26, 5-18 cm, Bas-Relief is declined in natural and neutral shades, applied in an innovative way. CODE: the texture is austere and refined. The severity is expressed through the movement which repeats itself on the surface as a code. PATCHWORK: the raised and overlapped details of the patchwork pattern create a design, which is constantly evolving and never repetitive. GARLAND: the flower element is revised with a contemporary and digital attitude. – The finishing of the surface reaches different depths and heights, which create an articulated "chiaroscuro" effect. CLOUD: this airy and light pattern captures the air bubbles on the surface and fixes them in a abstract and constant design. The slight differences in the pattern among the pieces are intentional to obtain a never repetitive laying effect.
patents	Registered design n° 001912999-0011 – date of registration: 06/09/2011 Registered design n° 001913062-004 – date of registration: 06/09/2011
category	UNI EN 14411 App A (AI group) UGL

WALLS



18-54 cm
7"-21"



Patchwork



Garland



Cloud

WALLS + FLOORS



26,5-18 cm
10,55"-7"



Code

Laying and maintenance tips

use	Code: Floor, wall – indoor, outdoor. Patchwork, Garland, Cloud: wall – indoor, outdoor.
installation	For an even, smooth shading effect when laying, alternate material from several different boxes.
recommended adhesive	NON-RAPID-DRYING adhesive for porcelain stoneware to make it easier to fix the pieces.
recommended joints	2mm joints. Use wedges to fix the caliber differences in work size between tiles.
recommended fillers	Cement-based grout/Epoxy grout. After grouting, remove the protective film and finish the joints with a sponge and clean water.
cleaning at the end of installation	CEMENT-BASED GROUT: Buffered acid (e.g. DETERDEK PRO by FILA, or similar). Wet the floor with water, dilute the product 1:5 with water and pour it on the floor. Wait for 2 or 3 minutes then use a white scotch brite pad and rinse well with clean water. EPOXY GROUT: Alkaline detergent (e.g. FILA CRT10 by FILA). FILA CRT10: apply pure, wait for 30 minutes then use a green scotch brite pad. SILICONE: Solvent for silicone (e.g. FILA ZERO SIL.). Pour it straight onto the stain, wait for 20 minutes and remove the mark using scotch brite. PAINT: Can usually be removed using water, but if resin-based paints or particular enamels have been used, it is best to ask the manufacturer which solvent is most suitable. RUST: stain remover es. FILA NO RUST. Apply the product onto the stain, leave for 15 minutes, remove the residue and rinse thoroughly.
general cleaning (installed tiles)	You are recommended to use ordinary neutral detergent diluted in water. Avoid using acid or alkaline products, waxes and/or impregnants. During ordinary cleaning it is recommended to use extremely abrasive items (such as scourers and iron or steel sponges) as little as possible. This recommendation must be adhered to rigorously in the case of tiles with a glossy surface finishing as they are more susceptible to the risk of scuffs, scratches and loss of shine, etc. In the event of heavy dirt or particularly textured surfaces, use an alkaline detergent and rinse after washing. For large surfaces, the use of a floor washing machine is recommended. During every-day cleaning procedures, it is necessary to remember that certain types of dirt (dust, sand) increase the abrasive effect of foot-traffic. Therefore we recommend that you avoid bringing in this type of dirt, which comes in from the outside, by placing a door-mat at the entrance.
calibers (real size)	The product is artisanal and hand made, thus each tile has a tolerance of +/- 2 mm.

Colors



Cloud bianco

Garland bianco

Patchwork bianco

Code bianco



Cloud cipria

Garland cipria

Patchwork cipria

Code cipria



Cloud nero

Garland nero

Patchwork nero

Code nero

For information about the available grouts, please contact the sales department.

Technical features

STANDARD	FEATURES	VALUE REQUIRED	BAS-RELIEF
ISO 10545/3	water absorption	$E \leq 3\%$	0,07%
ASTM C373			0,07%
ISO 10545/4	breaking strength	$Sp > 7,5 \text{ min } 1300$	resistant
ISO 10545/6	resistance to deep abrasion	$275 \text{ mm}^3 \text{ max}$	$274,4 \text{ mm}^3$
ISO 10545/9	resistance to thermal shock	no visible alteration	resistant
ASTM C484		unaffected	unaffected
ISO 10545/12	frost resistance	no visible alteration	resistant
ASTM C1026		unaffected	unaffected
ISO 10545/13	resistance to chemical attacks	no visible alteration	resistant
ASTM C650		unaffected	unaffected
ISO 10545/14	stains resistance	minimum 3	5
DIN 51130 - 04	slip resistance	medium values $6 \div 10^\circ$ R9 $10 \div 19^\circ$ R10 $19 \div 27^\circ$ R11 $27 \div 35^\circ$ R12 $> 35^\circ$ R13	R11
DIN 51097			
DCOF		$> 0,42$	0,56

Packing

SIZE	PCS-SQM	PCS-BOX	SQM-BOX	BOX-PAL	KG-BOX	KG-PAL	SQM-PAL
18-54 cm	10,29	10	0,97	45	19,45	875,00	43,65
26,5-18 cm	20,96	20	0,95	45	18,75	844,00	42,75

Botanica

collection	Botanica
design	Tokujin Yoshioka, 2022
production	Industrial
material	Glazed porcelain stoneware
thickness	9 mm
nominal sizes	Seed: net 40,5x23,7cm (9"x16") Flower: net 41,1x23,5cm (9"x16")
specification	<ul style="list-style-type: none"> - 2 colours: white, grey. - 2 finishes: matt, glossy. - Each piece pressed and non rectified. - Texture: smooth with pre-engravings. - Surface: matt and glossy made with digital glue technology plus interlocking grit with the structure on a porcelain stoneware support.
category	UNI EN 14411:2016 App.G (BIA Group) GL



Scan the QR code to download the technical features in other languages

FLOWER

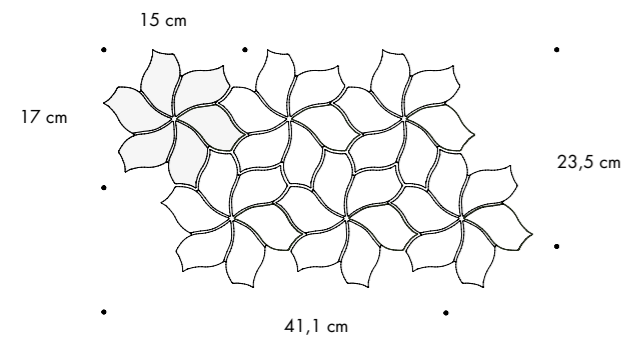

Sold exclusively on net

net 41,1-23,5 cm
net 9"x16"

SEED

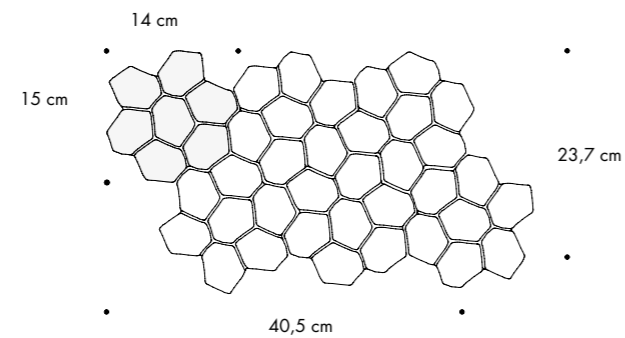

Sold exclusively on net

net 40,5-23,7 cm
net 9"x16"

Laying and maintenance tips

use	Floor, wall – indoor, outdoor.
installation	Lay on perfectly flat, dry walls.
recommended adhesive	Adhesive for porcelain stoneware.
recommended joints	3mm joints between each sheet.
recommended fillers	CEMENT-BASED GROUT / EPOXY GROUT. Remove all traces of grout carefully before it dries completely.
cleaning at the end of installation	CEMENT-BASED GROUT: Buffered acid (e.g. DETERDEK PRO by FILA or similar). Wet the floor with water, dilute the product 1:5 with water and pour it on the floor. Wait for 2-3 minutes then use a white scotch brite pad and rinse well with clean water. EPOXY GROUT: Alkaline detergent (e.g. FILA CR10 by FILA). FILA CR10: apply pure, wait for 30 minutes then use a green scotch brite pad. SILICONE: Solvent for silicone e.g. FILA ZERO SIL. Put it straight onto the stain, wait for 20 minutes and remove the mark using scotch brite. PAINT: Can usually be removed using water, but if resin-based paints or particular enamels have been used, it is best to ask the manufacturer which solvent is most suitable. RUST: stain remover es. FILA NO RUST. Apply the product onto the stain, leave for 15 minutes, remove the residue and rinse thoroughly.
general cleaning (installed tiles)	We advise using neutral detergent diluted in water. Do not use acid or alkaline products, waxes and/or stains. Where possible, for routine cleaning avoid the use of more abrasive products (scouring pads, metal sponges). It is strongly recommended not to use these products on tiles with glossy surface finish, as these are more susceptible to scratching, and may lose their shine, etc. For tough dirt and particularly rough surfaces, use an alkali detergent and rinse after washing. For large surfaces, the use of a floor cleaning machine is recommended. For day-to-day cleaning, remember that some types of dirt (dust, sand) increase the abrasive effect of foot traffic. You are therefore advised to place a mat at the entrance.
calibers (real size)	-

Colors

FLOWER

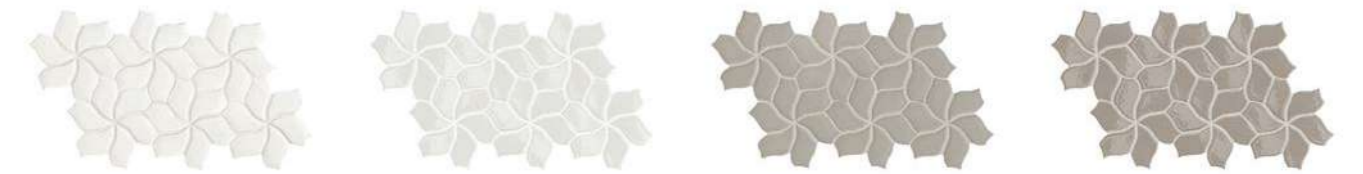

White Matt

White Glossy

Grey Matt

Grey Glossy

SEED



White Matt

White Glossy

Grey Matt

Grey Glossy

Technical features

STANDARD	FEATURES	VALUE REQUIRED	BOTANICA
ISO 10545/2	SIZES		
	length and width thickness straightness of edges wedging flatness	± 0,6% ± 5% ± 0,5% ± 0,5% ± 0,5%	in conformity with standard
ISO 10545/3	water absorption	< 0,5%	0,2%
ISO 10545/4	breaking strength modulus of rupture	≥ 1300 N ≥ 32 N/mm ²	in conformity with standard
ISO 10545/9	resistance to thermal shock	comply requirements	resistant
ISO 10545/12	frost resistance	comply requirements	resistant
ISO 10545/13	resistance to acids and alkalis (low and high concentration) Resistance to household cleaning agents and swimming pool chemicals	declared value minimum class B	A A
ISO 10545/14	stains resistance	minimum class 3	5
DIN 51130			R9 matt
DIN 51097			B matt A glossy
DCOF		> 0,42	0,52 matt 0,31 glossy
Pendulum BS (EN 16165-c)			55/25 matt dry/wet 57/23 glossy dry/wet
Pendulum AS/NZS (4586313 app A)			26 P2 matt 23 P1 glossy
Pendulum ES (UNE 41901)			C1 matt/glossy
LEED CERTIFICATION 4.1			24%
VOC Emission			Available upon request
EPD			Available upon request
Declaration of Contents			Available upon request
SVHC declaration			Available upon request

Packing

SIZE	PCS-SQM	PCS-BOX	SQM-BOX	BOX-PAL	KG-BOX	KG-PAL	SQM-PAL
Flower all colours net 41,1-23,5 cm	10,35	5	0,48	60	8,50	510	28,80
Seed all colours net 40,5-23,7 cm	10,42	5	0,48	60	8,25	495	28,80



Scan the QR code to download the technical features in other languages

Chymia

collection	Chymia
design	Laboratorio Avallone, 2019
production	Industrial
material	Rectified glazed porcelain stoneware
thickness	10 mm
nominal sizes	30x30 cm
specification	The slight differences in the pattern among the pieces are intentional to obtain a never repetitive laying effect. The collection is: – 11 textures in White and Black – 4 mix, with 6 different items
complementary pieces	Skirting
patents	Registered design n° 007510870-0001/0040 – date of registration: 14/01/2020
category	UNI EN 14411 App G (BIA group) GL

complementary pieces

skirting
3,8-30 cm
1 1/2" x 12"

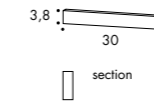

Laying and maintenance tips

use	Floor, wall – indoor, outdoor.
installation	For an even, smooth shading effect when laying, alternate material from several different boxes.
recommended adhesive	Adhesive for porcelain stoneware.
recommended joints	2mm joints. Use wedges to fix the caliber differences in work size between tiles.
recommended fillers	Cement-based grout / epoxy grout.
cleaning at the end of installation	CEMENT-BASED GROUT: Buffered acid (e.g. DETERDEK PRO by FILA, or similar). Wet the floor with water, dilute the product 1:5 with water and pour it on the floor. Wait for 2 or 3 minutes then use a white scotch brite pad and rinse well with clean water. EPOXY GROUT: Alkaline detergent (e.g. FILA CR10 by FILA). FILA CR10: apply pure, wait for 30 minutes then use a green scotch brite pad. SILICONE: Solvent for silicone (e.g. FILA ZERO SIL.). Pour it straight onto the stain, wait for 20 minutes and remove the mark using scotch brite. PAINT: Can usually be removed using water, but if resin-based paints or particular enamels have been used, it is best to ask the manufacturer which solvent is most suitable. RUST: stain remover es. FILA NO RUST. Apply the product onto the stain, leave for 15 minutes, remove the residue and rinse thoroughly.
general cleaning (installed tiles)	You are recommended to use ordinary neutral detergent diluted in water. Avoid using acid or alkaline products, waxes and/or impregnants. During ordinary cleaning it is recommended to use extremely abrasive items (such as scourers and iron or steel sponges) as little as possible. This recommendation must be adhered to rigorously in the case of tiles with a glossy surface finishing as they are more susceptible to the risk of scuffs, scratches and loss of shine, etc. In the event of heavy dirt or particularly textured surfaces, use an alkaline detergent and rinse after washing. For large surfaces, the use of a floor washing machine is recommended. During every-day cleaning procedures, it is necessary to remember that certain types of dirt (dust, sand) increase the abrasive effect of foot-traffic. Therefore we recommend that you avoid bringing in this type of dirt, which comes in from the outside, by placing a door-mat at the entrance.
calibers (real size)	298 mm x 298 mm

Colors



Flat White Flat Black



Rigo White Rigo Black



Frost White Frost Black

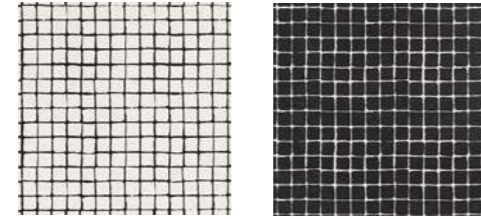

Tassello White Tassello Black



Ophelia White Ophelia Black

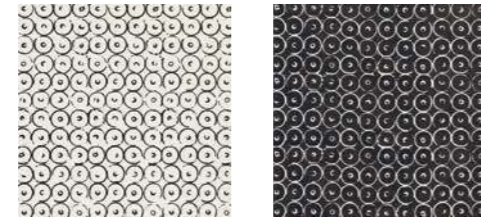

Cosmo White Cosmo Black



Mix 1 White



Mix 1 Black

Colors

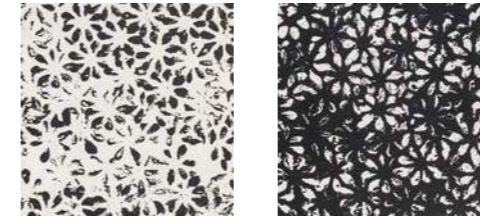

Bloom White Bloom Black



Drops White Drops Black



Juta White Juta Black



Impronta White Impronta Black

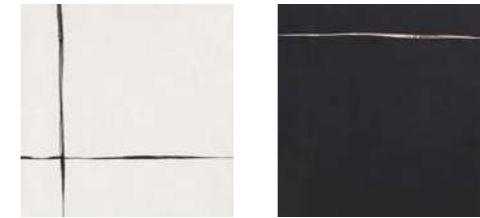

Teorema White * Teorema Black *

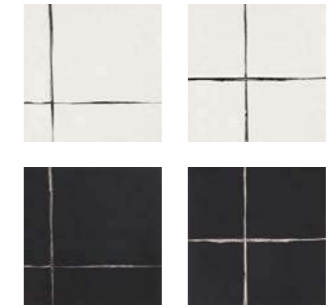

different patterns randomly mixed into the box

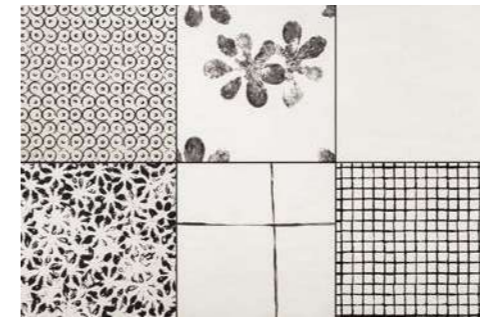

Mix 2 White

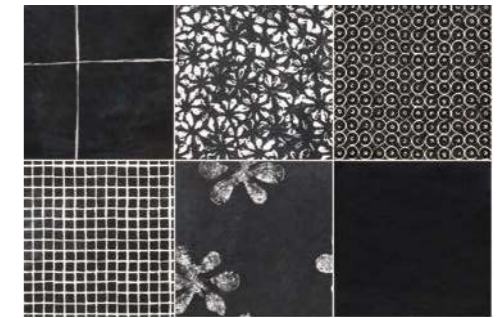

Mix 2 Black

For information about the available grouts, please contact the sales department.

Technical features

STANDARD	FEATURES	VALUE REQUIRED	CHYMIA
ISO 10545/3	water absorption	< 0,5%	0,06%
ISO 10545/4	breaking strength	Sp> 7,5 min 1300	resistant
ISO 10545/9	thermal shock resistance	no alteration	no alteration
ISO 10545/12	frost resistance	no alteration	no alteration
ISO 10545/13	acids and alkalis resistance	min B	A
ISO 10545/14	stains resistance	class 3	class 5
DIN 51130-04	slip resistance	medium values 6÷10° R9 10÷19° R10 19÷27° R11 27÷35° R12 > 35° R13	R9 Flat R10
DIN 51097		–	A Flat B
DCOF		>0,42	> 0,59
Pendulum BS7976-2		–	45 dry / 25 wet Flat 56 dry/ 42 wet
LEED 4.1		–	20%
Robinson Test			heavy use
VOC Emission			available upon request
Declaration of Contents			available upon request
SDS			available upon request
EPD			available upon request
BPD3			available upon request
HPD			available upon request

Packing

SIZE	PCS-SQM	PCS-BOX	SQM-BOX	BOX-PAL	KG-BOX	KG-PAL	SQM-PAL
30-30 cm	11,11	9	0,81	32	16,90	540,81	25,92
mix 30-30 cm	11,11	12	1,08	22	22,30	490,60	23,76
skirting 3,8-30 cm		20	6 ml		4,80		



Scan the QR code to download the technical features in other languages

Déchirer

Déchirer Decor, Neutral

collection	Déchirer
design	Patricia Urquiola, 2008
production	Industrial
material	Unglazed homogeneous porcelain stoneware
features	Squared and rectified slabs each one exactly the same as the others
thickness	12 mm
nominal sizes	DECOR: mosaico random 21,4-44,4 cm (8"· 17") DECOR: 120-120 cm (47"·47"), 60-120 cm (24"·47"), 60-60 cm (24"·24") DECOR: esagona 120-120 cm (47"·47"), esagona 60-60 cm (24"·24") NEUTRAL: 120-120 cm (47"·47"), 60-120 cm (24"·47"), 60-60 cm (24"·24")
specification	– 5 base colors – Relief texture "Decor" in 5 colors (registered design) – CONTINUA Technology production system (environmental certification ISO 14001:2004)
complementary pieces	Step, Corner tile, Skirting
awards	Edida 2009, Best of Neocon 2009, Home beautiful product 2009, Selected for Adi Design Index 2009, Good Design 2010, ICFE Editors Award Material 2011
patents	Registered design n° 001615790-001 – date of registration: 25/09/2009 Registered design n° 001615774-001 – date of registration: 25/09/2009
category	UNI EN 14411 App G (BIA group) UGL

DECOR

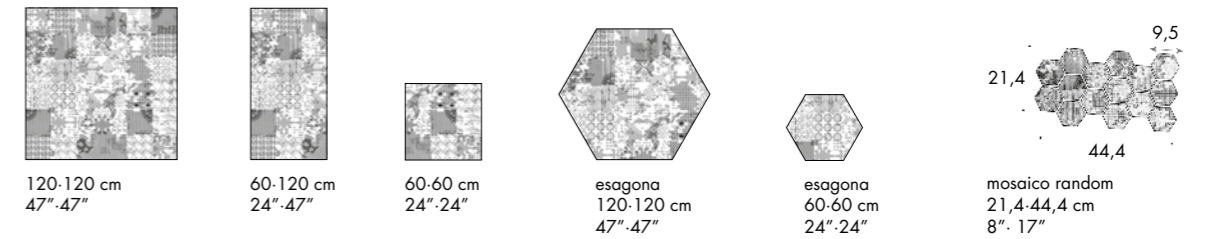

NEUTRAL

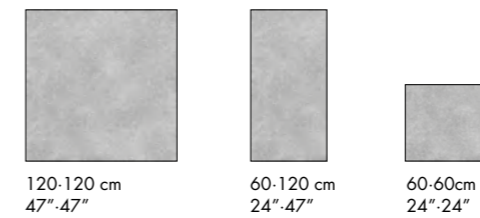

complementary pieces

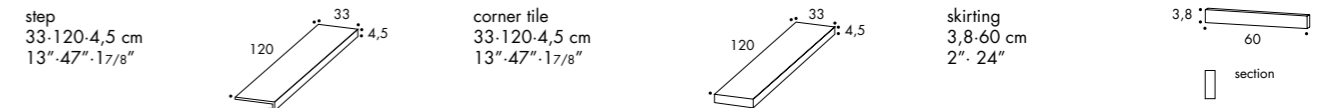

Laying and maintenance tips

use	Floor, wall – indoor, outdoor.
installation	For an even, smooth shading effect when laying, alternate material from several different boxes. The double spreading technique is recommended for the 120x120 size.
recommended adhesive	Adhesive for porcelain stoneware.
recommended joints	2mm joints. Use wedges to fix the caliber differences in work size between tiles.
recommended fillers	Cement-based grout / epoxy grout. Remove all traces of grout carefully before it dries completely.
cleaning at the end of installation	CEMENT-BASED GROUT: Buffered acid (e.g. DETERDEK PRO by FILA, or similar). Wet the floor with water, dilute the product 1:5 with water and pour it on the floor. Wait for 2 or 3 minutes then use a white scotch brite pad and rinse well with clean water. EPOXY GROUT: Alkaline detergent (e.g. FILA CR10 by FILA). FILA CR10: apply pure, wait for 30 minutes then use a green scotch brite pad. SILICONE: Solvent for silicone (e.g. FILA ZERO SIL.). Pour it straight onto the stain, wait for 20 minutes and remove the mark using scotch brite. PAINT: Can usually be removed using water, but if resin-based paints or particular enamels have been used, it is best to ask the manufacturer which solvent is most suitable. RUST: stain remover es. FILA NO RUST. Apply the product onto the stain, leave for 15 minutes, remove the residue and rinse thoroughly.
general cleaning (installed tiles)	You are recommended to use ordinary neutral detergent diluted in water. Avoid using acid or alkaline products, waxes and/or impregnants. During ordinary cleaning it is recommended to use extremely abrasive items (such as scourers and iron or steel sponges) as little as possible. This recommendation must be adhered to rigorously in the case of tiles with a glossy surface finishing as they are more susceptible to the risk of scuffs, scratches and loss of shine, etc. In the event of heavy dirt or particularly textured surfaces, use an alkaline detergent and rinse after washing. For large surfaces, the use of a floor washing machine is recommended. During every-day cleaning procedures, it is necessary to remember that certain types of dirt (dust, sand) increase the abrasive effect of foot-traffic. Therefore we recommend that you avoid bringing in this type of dirt, which comes in from the outside, by placing a door-mat at the entrance.
calibers (real size)	120cm x 120cm -> 1190mm x 1190mm 60cm x 60cm -> 594mm x 594mm 60cm x 120cm -> 594mm x 1190mm

Colors



Decor Bianco



Neutral Bianco



Decor Grigio



Neutral Grigio



Decor Piombo

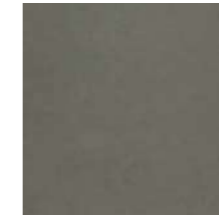

Neutral Piombo



Decor Nero



Neutral Nero

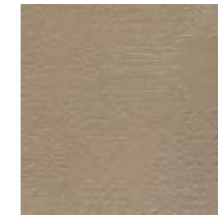

Decor Ecrù



Neutral Ecrù

For information about the available grouts, please contact the sales department.

Technical Features

STANDARD	FEATURES	VALUE REQUIRED	DÉCHIRER
ISO 10545/3	water absorption	< 0,5%	0,06%
ASTM C373		< 0,5%	0,06%
ISO 10545/4	breaking strength	≥ 35 N/mm ²	61,2 N/mm ²
ISO 10545/6	resistance to deep abrasion	<175 mm ³	in conformity
EN 101	surface hardness (scala mohs)	> 5	8
ISO 10545/9	resistance to thermal shock	no visible alteration	resistant
ASTM C484		no samples must show visible defects	unaffected
ISO 10545/12	frost resistance	no visible alteration	resistant
ASTM C1026		unaffected	unaffected
ISO 10545/13	resistance to chemical attacks	minimum B	A
ASTM C650			
ISO 10545/14	stains resistance	class 3	class 5
DIN 51130-04	slip resistance	medium values 6±10° R9 10±19° R10 19±27° R11 27±35° R12 > 35° R13	déchirer neutral R10 déchirer decor R10
DIN 51097			B
DCOF		–	
Pendulum ENV12633			Class 1
 UPEC			available upon request
LEED CERTIFICATION 4.1			20% recycled material
ENVIRONMENTAL MANAGEMENT SYSTEM ISO 14000 E ISO 9001			
VOC Emission			available upon request
Declaration of Contents			available upon request
EPD			available upon request
SDS			available upon request
BPD3			available upon request
HPD			available upon request

Déchirer Glass

collection	Déchirer
design	Patricia Urquiola, 2009
production	Artisanal
material	Recycled glass mosaic
thickness	4,5 mm
nominal sizes	0,9-0,9 cm on net 30-30 cm (12".12")
specification	The collection is: – 5 base colors
category	–

GLASS

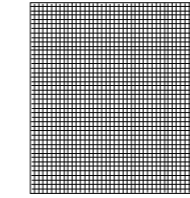

0,9-0,9 cm on net 30-30 cm
12".12"

Laying and maintenance tips

use	Floor, wall – indoor, outdoor.
installation	Lay on perfectly flat, dry walls.
recommended adhesive	Epoxy adhesive for vitreous glass mosaics. Use with a fine-tooth spatula, max. height 3 mm. Use white adhesive on WHITE tiles. Use grey adhesive on OTHER COLOURS.
recommended joints	Place the sheets with the same joint as within the sheet. WAIT UNTIL THE ADHESIVE HAS DRIED COMPLETELY BEFORE REMOVING THE ADHESIVE FILM (at least 72 hours if cement-based adhesive is used).
recommended fillers	Epoxy grout. Remove all traces of grout carefully before it dries completely. Shade-on-shade grout is recommended.
cleaning at the end of installation	EPOXY GROUT: Alkaline detergent (e.g. FILA CR10 by FILA). FILA CR10: apply pure, wait for 30 minutes then use a green scotch brite pad. SILICONE: Solvent for silicone (e.g. FILA ZERO SIL.). Pour it straight onto the stain, wait for 20 minutes and remove the mark using scotch brite. PAINT: Can usually be removed using water, but if resin-based paints or particular enamels have been used, it is best to ask the manufacturer which solvent is most suitable. RUST: stain remover es. FILA NO RUST. Apply the product onto the stain, leave for 15 minutes, remove the residue and rinse thoroughly.
general cleaning (installed tiles)	You are recommended to use ordinary neutral detergent diluted in water. Avoid using acid or alkaline products, waxes and/or impregnants. During ordinary cleaning it is recommended to use extremely abrasive items (such as scourers and iron or steel sponges) as little as possible. This recommendation must be adhered to rigorously in the case of tiles with a glossy surface finishing as they are more susceptible to the risk of scuffs, scratches and loss of shine, etc. In the event of heavy dirt or particularly textured surfaces, use an alkaline detergent and rinse after washing. For large surfaces, the use of a floor washing machine is recommended. During every-day cleaning procedures, it is necessary to remember that certain types of dirt (dust, sand) increase the abrasive effect of foot-traffic. Therefore we recommend that you avoid bringing in this type of dirt, which comes in from the outside, by placing a door-mat at the entrance.
calibers (real size)	–

Colors



Glass Bianco



Glass Grigio



Glass Piombo



Glass Nero



Glass Ecrù

For information about the available grouts, please contact the sales department.

Technical Features

STANDARD	FEATURES	VALUE REQUIRED	GLASS
ISO 10545/3	water absorption	<0,5%	0,00%
ISO 10545/9	thermal shock resistance	no alteration	resistant
ISO 10545/12	frost resistance	no alteration	resistant
ISO 10545/13	acids and alkalis resistance	min B	A
ISO 10545/14	stains resistance	class 3	class 5
DIN 51094	colours resistance to fading		no alteration
LEED CERTIFICATION 4.1			40% recycled material
VOC Emission			available upon request
Declaration of Contents			available upon request
SDS			available upon request
BPD3			available upon request
HPD			available upon request

Déchirer (La Suite)

Déchirer^(La Suite) Net, Trace

collection	Déchirer
design	Patricia Urquiola, 2010
production	Industrial
material	Unglazed homogeneous porcelain stoneware
features	Squared and rectified slabs each one exactly the same as the others
thickness	12 mm
nominal sizes	NET: 120-120 cm (47"-47"), 30-120 cm (12"-47"), 60-60 cm (24"-24") TRACE: 120-120 cm (47"-47"), 30-120 cm (12"-47"), 60-60 cm (24"-24")
specification	- 3 base colors - 2 engraved textures, Trace and Net, in 3 colors (registered design) - CONTINUA Technology production system (environmental certification ISO 14001:2004)
complementary pieces	TRACE: Step, Corner tile, Skirting
patents	Registered design n° 001913062-0005 – date of registration: 06/09/2011 Registered design n° 001912999-0014 – date of registration: 06/09/2011
category	UNI EN 14411 App G (BIA group) UGL

NET

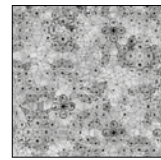

120-120 cm
47"-47"



30-120 cm
12"-47"



60-60 cm
24"-24"

TRACE



120-120 cm
47"-47"



30-120 cm
12"-47"



60-60 cm
24"-24"

complementary pieces

step
30-120-4,5 cm
12"-47"-1 7/8"

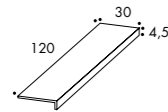

corner tile
30-120-4,5 cm
12"-47"-1 7/8"

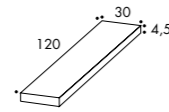

skirting
3,8-60 cm
2"-24"

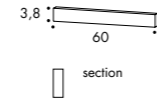

Scan the QR code to download the technical features in other languages

Laying and maintenance tips

use	Floor, wall – indoor, outdoor.
installation	For an even, smooth shading effect when laying, alternate material from several different boxes. The double spreading technique is recommended for the 120x120 size.
recommended adhesive	Adhesive for porcelain stoneware.
recommended joints	2mm joints. Use wedges to fix the caliber differences in work size between tiles.
recommended fillers	Cement-based grout / epoxy grout. Remove all traces of grout carefully before it dries completely.
cleaning at the end of installation	CEMENT-BASED GROUT: Buffered acid (e.g. DETERDEK PRO by FILA, or similar). Wet the floor with water, dilute the product 1:5 with water and pour it on the floor. Wait for 2 or 3 minutes then use a white scotch brite pad and rinse well with clean water. EPOXY GROUT: Alkaline detergent (e.g. FILA CR10 by FILA). FILA CR10: apply pure, wait for 30 minutes then use a green scotch brite pad. SILICONE: Solvent for silicone (e.g. FILA ZERO SIL.). Pour it straight onto the stain, wait for 20 minutes and remove the mark using scotch brite. PAINT: Can usually be removed using water, but if resin-based paints or particular enamels have been used, it is best to ask the manufacturer which solvent is most suitable. RUST: stain remover es. FILA NO RUST. Apply the product onto the stain, leave for 15 minutes, remove the residue and rinse thoroughly.
general cleaning (installed tiles)	You are recommended to use ordinary neutral detergent diluted in water. Avoid using acid or alkaline products, waxes and/or impregnants. During ordinary cleaning it is recommended to use extremely abrasive items (such as scourers and iron or steel sponges) as little as possible. This recommendation must be adhered to rigorously in the case of tiles with a glossy surface finishing as they are more susceptible to the risk of scuffs, scratches and loss of shine, etc. In the event of heavy dirt or particularly textured surfaces, use an alkaline detergent and rinse after washing. For large surfaces, the use of a floor washing machine is recommended. During every-day cleaning procedures, it is necessary to remember that certain types of dirt (dust, sand) increase the abrasive effect of foot-traffic. Therefore we recommend that you avoid bringing in this type of dirt, which comes in from the outside, by placing a door-mat at the entrance.
calibers (real size)	60cm x 60cm -> 594mm x 594mm 120cm x 120cm -> 1190mm x 1190mm 30cm x 120cm -> 296mm x 1190mm

Colors

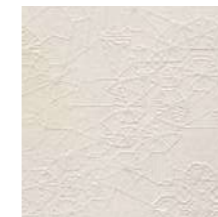

Net Calce



Trace Calce



Net Cemento

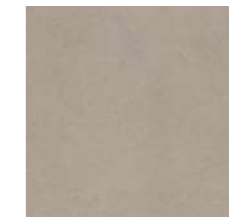

Trace Cemento



Net Cenere



Trace Cenere

For information about the available grouts, please contact the sales department.

Technical Features

STANDARD	FEATURES	VALUE REQUIRED	DÉCHIRER (LA SUITE)
ISO 10545/3	water absorption	< 0,5%	0,06%
ASTM C373		< 0,5%	0,06%
ISO 10545/4	breaking strength	≥ 35 N/mm ²	61,2 N/mm ²
ISO 10545/6	resistance to deep abrasion	<175 mm ³	in conformity
EN 101	surface hardness (scala mohs)	> 5	8
ISO 10545/9	resistance to thermal shock	no visible alteration	resistant
ASTM C484		no samples must show visible defects	unaffected
ISO 10545/12	frost resistance	no visible alteration	resistant
ASTM C1026		unaffected	unaffected
ISO 10545/13	resistance to chemical attacks	no visible alteration	resistant
ASTM C650			unaffected
ISO 10545/14	stains resistance	class 3	class 5
DIN 51130-04	slip resistance	medium values 6÷10° R9 10÷19° R10 19÷27° R11 27÷35° R12 > 35° R13	net R11 trace R11
DIN 51097			B
DCOF		-	-
Pendulum EN12633			-
 UPEC			available upon request
LEED CERTIFICATION 4.1			20% recycled material
ENVIROMENTAL MANAGEMENT SYSTEM ISO 14000 E ISO 9001			
VOC Emission			available upon request
Declaration of Contents			available upon request
EPD			available upon request
SDS			available upon request
BPD3			available upon request
HPD			available upon request

Packing

SIZE	PCS-SQM	SQM-PC	PC-PAL	KG-PC	KG-PAL	SQM-PAL
120-120 cm	0,69	1,44	36	38,30	1379,00	51,84

SIZE	PCS-SQM	PCS-BOX	SQM-BOX	BOX-PAL	KG-BOX	KG-PAL	SQM-PAL
esagona 120-120 cm	1,07	1	0,93	36	25,10	904	33,48
60-120 cm	1,38	2	1,44	24	38,65	928	34,56
30-120 cm	2,78	2	0,72	48	19,10	917	34,56
60-60 cm	2,77	3	1,08	32	29,00	928	34,56
esagona 60-60 cm	4,30	4	0,92	24	25,15	604	22,08
mosaico random decor 21,4-44,4 cm	10,52	5	0,47	56	12,50	700	26,60
step 30-120-4,5 cm	-	2	2,40 ml	-	26,00	-	-
corner tile 30-120-4,5	-	1	1,20 ml	-	13,00	-	-
skirting 3,8-60 cm	-	10	6,00 ml	-	5,85	-	-
déchirer glass 30-30 cm	11	11	1,00	60	6,05	363	60,00

Déchirer XL

collection	Déchirer XL
design	Patricia Urquiola, 2017
production	Industrial
material	Unglazed homogeneous porcelain stoneware
thickness	3 mm reinforced with back glass fiber
features	Squared and rectified slabs each one exactly the same as the others
nominal sizes	100-300 cm (39".118")
specification	<ul style="list-style-type: none"> – Unglazed porcelain stoneware body and available in three shades: gesso, grafite and avana. – Déchirer was the breakthrough that distinguished Mutina in the world of designer tiles, and is still considered one of the most emblematic collections of its kind. Mutina has decided to celebrate this great success by proposing Déchirer in a new, XL size in the lowest possible thickness (3 mm with fiber back layer), and in a very lightweight slab (25 kg). – Size 100 x 300 cm, to have the bas-relief decorations (registered design) extended over a continuous, larger surface. – Pure ceramic body pressed in a latest generation machine to create textured surfaces even on large slabs – Details of the bas-relief with perfectly well-defined edges – Rectified in real size 100x300
patents	Registered design n° 001615790-001 – date of registration: 25/09/2009 Registered design n° 001615774-001 – date of registration: 25/09/2009
category	UNI EN 14411 App G (BIA group) UGL



100-300 cm
39".118"



Scan the QR code to download the technical features in other languages

Laying and maintenance tips

use	Wall – indoor, outdoor.
installation	Place the base of the chosen leveller under the flooring/tile and continue laying in sequence. Insert the tie rod in the threaded shaft and turn it clockwise until the flooring/tile is level, using as little pressure as possible. When the adhesive/glue has solidified and the adhesion to floor is sufficiently level: break the tie rod.
recommended adhesive	It is possible to use Class C2S2 cementitious adhesives to lay the slabs on substrates such as concrete, gypsum-based plaster (after applying a primer) or cement, plasterboard or fibre-cement panels, and old ceramic tiles. Always apply a "double layer" or "full layer" of adhesive using back buttering. Back buttering is, therefore, always recommended. Apply the adhesive with back buttering, first on the back of the slab and then, on the substrate, taking care to cover the corners and edges, avoiding any air pockets between the substrate and the slab. Spread the adhesive as required only on the surface where a slab is being laid to prevent the surface from skinning over which stops it from adhering. It is recommended to use a 6 mm notched trowel for the substrate and a 3 mm notched trowel for the back of the slab, taking care to spread the adhesive in the same direction, both on the slab and the substrate, and to knock the surface with a rubber mallet, making sure any air pockets are eliminated.
recommended joints	2mm joints. Use wedges to fix the caliber differences in work size between tiles.
recommended fillers	Cementitious grout / epoxy grout.
cleaning at the end of installation	CEMENT-BASED GROUT: Buffered acid (e.g. DETERDEK PRO by FILA, or similar). Wet the floor with water, dilute the product 1:5 with water and pour it on the floor. Wait for 2 or 3 minutes then use a white scotch brite pad and rinse well with clean water. EPOXY GROUT: Alkaline detergent (e.g. FILA CR10 by FILA). FILA CR10: apply pure, wait for 30 minutes then use a green scotch brite pad. SILICONE: Solvent for silicone (e.g. FILA ZERO SIL.). Pour it straight onto the stain, wait for 20 minutes and remove the mark using scotch brite. PAINT: Can usually be removed using water, but if resin-based paints or particular enamels have been used, it is best to ask the manufacturer which solvent is most suitable. RUST: stain remover es. FILA NO RUST. Apply the product onto the stain, leave for 15 minutes, remove the residue and rinse thoroughly.
general cleaning (installed tiles)	You are recommended to use ordinary neutral detergent diluted in water. Avoid using acid or alkaline products, waxes and/or impregnants. During ordinary cleaning it is recommended to use extremely abrasive items (such as scourers and iron or steel sponges) as little as possible. This recommendation must be adhered to rigorously in the case of tiles with a glossy surface finishing as they are more susceptible to the risk of scuffs, scratches and loss of shine, etc. In the event of heavy dirt or particularly textured surfaces, use an alkaline detergent and rinse after washing. For large surfaces, the use of a floor washing machine is recommended. During every-day cleaning procedures, it is necessary to remember that certain types of dirt (dust, sand) increase the abrasive effect of foot-traffic. Therefore we recommend that you avoid bringing in this type of dirt, which comes in from the outside, by placing a door-mat at the entrance.
calibers (real size)	1000mm x 3000mm

Colors



Gesso



Grafite



Avana

For information about the available grouts, please contact the sales department.

Technical features

STANDARD	FEATURES	VALUE REQUIRED	DÉCHIRER XL
ISO 10545/2	SIZES		
	length and width	± 0,6%	in conformity with standard
	thickness	± 5%	
	straightness of edges	± 0,5%	
	wedging	± 0,5%	
	flatness	± 0,5%	
ISO 10545/3	water absorption	< 0,5%	in conformity with standard
ISO 10545/6	resistance to deep abrasion	–	–
ISO 10545/9	resistance to thermal shock	no visible alteration	resistant
ASTM C484		no samples must show visible defects	unaffected
ISO 10545/12	frost resistance	no visible alteration	resistant
ISO 10545/13	resistance to chemical attacks	no visible alteration	resistant
ISO 10545/14	stains resistance	class 3	class 5
DIN 51130-04	slip resistance	–	–
DIN 51097		–	–
DCOF		–	–
Pendulum AS/NSZ 4586-13			–
EN 13501 (rev. 2005)			A2-s 1, d0
Leed 4.1			30% pre-consumer recycled material (Déchirer XL Gesso) 40% pre-consumer recycled material (Déchirer XL Grafite and Avana)
ISO 9001 – ISO 14001			
Robinson Test		–	–
VOC Emission			available upon request
Declaration of contents			available upon request
EPD			available upon request
SDS			available upon request
BPD3			available upon request
HPD			available upon request



Packing

SIZE	PCS-SQM	PCS-BOX	SQM-PC	PC-PAL	KG-PC	KG-PAL	SQM-PAL
100-300 cm	0,33	1	3,00	20	24,60	492,00	60



Scan the QR code to download the technical features in other languages

Diarama

collection	Diarama
design	Hella Jongerius, 2018
production	Industrial
material	Glazed homogeneous porcelain stoneware
thickness	9 mm
sizes	9,4-18,7 cm (345/64"-723/64")
specification	<ul style="list-style-type: none"> – 7 matt color bases – 2 main colors: Chalk and Iron – 4 color families: Ash, Sky, Maize, Blush all in light and dark version – 3 mix: Dusk (Chalk+Iron), Grey Chroma and Black Chroma (9 different colors on the same base) – Glazed stripes on a unglazed surface applied with high-thickness serigraphic printing technology – Color nuances deliberately shaded through the interaction between the base color and the glaze
patent	Registered design n° 006336608-0001/0037 – date of registration: 26/03/2019
category	UNI EN 14411 App G (BIA group) GL



9,4-18,7 cm
(345/64"-723/64")

Laying and maintenance tips

use	Wall – indoor, outdoor.
installation	The material is deliberately shaded. Take the material of the same box and mix randomly.
recommended adhesive	Adhesive for porcelain stoneware.
recommended joints	2mm joints. Use wedges to fix the caliber differences in work size between tiles.
recommended fillers	Fine-grain cement-based grout / epoxy grout.
cleaning at the end of installation	<p>CEMENT-BASED GROUT: Buffered acid (e.g. DETERDEK PRO by FILA, or similar). Wet the floor with water, dilute the product 1:5 with water and pour it on the floor. Wait for 2 or 3 minutes then use a white scotch brite pad and rinse well with clean water.</p> <p>EPOXY GROUT: Alkaline detergent (e.g. FILA CR10 by FILA). FILA CR10: apply pure, wait for 30 minutes then use a green scotch brite pad.</p> <p>SILICONE: Solvent for silicone (e.g. FILA ZERO SIL.). Pour it straight onto the stain, wait for 20 minutes and remove the mark using scotch brite.</p> <p>PAINT: Can usually be removed using water, but if resin-based paints or particular enamels have been used, it is best to ask the manufacturer which solvent is most suitable.</p> <p>RUST: stain remover es. FILA NO RUST. Apply the product onto the stain, leave for 15 minutes, remove the residue and rinse thoroughly.</p>
general cleaning (installed tiles)	You are recommended to use ordinary neutral detergent diluted in water. Avoid using acid or alkaline products, waxes and/or impregnants. During ordinary cleaning it is recommended to use extremely abrasive items (such as scourers and iron or steel sponges) as little as possible. This recommendation must be adhered to rigorously in the case of tiles with a glossy surface finishing as they are more susceptible to the risk of scuffs, scratches and loss of shine, etc. In the event of heavy dirt or particularly textured surfaces, use an alkaline detergent and rinse after washing.
calibers (real size)	9,4 cm x 18,7 cm with 1 mm tolerance

Colors

BLACK AND WHITE



Chalk

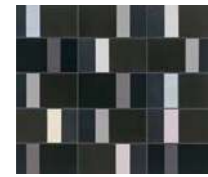

Iron

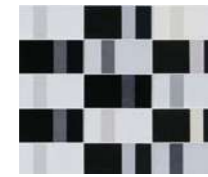

Dusk

MIX



Grey Chroma



Black Chroma

DIARAMA COLORS



Ash Light



Ash Dark

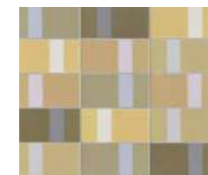

Maize Light



Maize Dark



Blush Light



Blush Dark



Sky Light

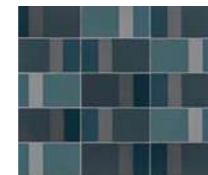

Sky Dark

installation ideas

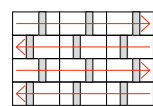

Alternated horizontal

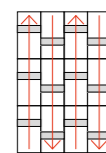

Alternated vertical



Random horizontal

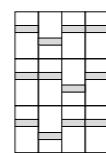

Random vertical

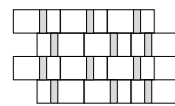

Random horizontal running bond

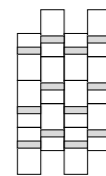

Random vertical running bond

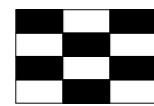

Checkerboard (Diarama Dusk)

For information about the available grouts, please contact the sales department.

Technical features

STANDARD	FEATURES	VALUE REQUIRED	DIARAMA
ISO 10545/3	water absorption	< 0,5%	in conformity with standard
ISO 10545/4	breaking strength	Sp> 7,5 min 1300	in conformity with standard
ISO 10545/9	resistance to thermal shock	no visible alteration	resistant
ASTM C484		no samples must show visible defects	unaffected
ISO 10545/12	frost resistance	no visible alteration	resistant
ISO 10545/13	resistance to chemical attacks	no visible alteration	resistant
ISO 10545/14	stains resistance	minimum 3	5
DIN 51130-04	slip resistance	-	-
DIN 51097		-	-
DCOF		-	-
Pendulum AS/NSZ 4586-13			-
LEED CERTIFICATION 4.1			24% pre-consumer recycled material
Robinson Test		-	
VOC Emission			available upon request
Declaration of Contents			available upon request
SDS			available upon request
BPD3			available upon request
HPD			available upon request



Packing

SIZE	PCS-SQM	PCS-BOX	SQM-BOX	BOX-PAL	KG-BOX	KG-PAL	SQM-PAL
all colors 9,4x18,7 cm	56,89	45	0,79	48	16,95	813,60	37,92
dusk, chalk, iron 9,4x18,7 cm	56,89	42	0,74	48	15,82	759,36	35,52

Din

collection	Din
design	Konstantin Grcic, 2021
production	Industrial
material	Glazed pressed and not rectified body
thickness	9 mm
nominal sizes	15.15 cm (6".6") – 7,4.15 cm (3".6") – 7,4.7,4 cm (3".3") – 3,6.7,4 cm (1,5".3")
specification	<ul style="list-style-type: none"> – 8 colors: White, Black, Light Blue, Dark Blue, Light Green, Dark Green, Rose, Red – 2 finishes: Matt and Glossy – The Elements in sizes 7,4x7,4 cm and 3,6 x 7,4 cm are both sold on net 30,2x30,2 cm (12".12")* – All the tiles present a solid natural, slightly mottled effect typical of artisanal products
category	Bib UNI EN 14411 (GI)

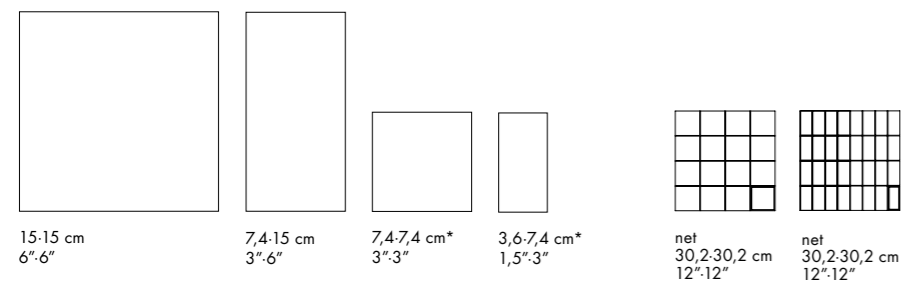

Laying and maintenance tips

use	Floor, wall – indoor, outdoor
installation	Lay on perfectly flat, dry walls.
recommended adhesive	Non-rapid-drying adhesive for porcelain stoneware to make it easier to fix the sheets.
recommended joints	2mm. Place the sheets with the same joint as within the sheet.
recommended fillers	CEMENT-BASED GROUT: Grout 0.5 m2 at a time and wash thoroughly with clean water. Remove all traces of grout carefully before it dries completely. EPOXY GROUT: Grout 0.5 m2 at a time and wash thoroughly with clean water. Remove all traces of grout carefully before it dries completely.
cleaning at the end of installation	CEMENT-BASED GROUT: Buffered acid (e.g. DETERDEK PRO by FILA or similar). Wet the floor with water, dilute the product 1:5 with water and pour it on the floor. Wait for 2-3 minutes then use a white scotch brite pad and rinse well with clean water. EPOXY GROUT: Alkaline detergent (e.g. FILA CR10 by FILA). FILA CR10: apply pure, wait for 30 minutes then use a green scotch brite pad. SILICONE: Solvent for silicone e.g. FILA ZERO SIL. Put it straight onto the stain, wait for 20 minutes and remove the mark using scotch brite. PAINT: Can usually be removed using water, but if resin-based paints or particular enamels have been used, it is best to ask the manufacturer which solvent is most suitable. RUST: stain remover es. FILA NO RUST. Apply the product onto the stain, leave for 15 minutes, remove the residue and rinse thoroughly.
general cleaning (installed tiles)	You are recommended to use ordinary neutral detergent diluted in water. Avoid using acid or alkaline products, waxes and/or impregnants. During ordinary cleaning it is recommended to use extremely abrasive items (such as scourers and iron or steel sponges) as little as possible. This recommendation must be adhered to rigorously in the case of tiles with a glossy surface finishing as they are more susceptible to the risk of scuffs, scratches and loss of shine, etc. In the event of heavy dirt or particularly textured surfaces, use an alkaline detergent and rinse after washing. For large surfaces, the use of a floor washing machine is recommended. During every-day cleaning procedures, it is necessary to remember that certain types of dirt (dust, sand) increase the abrasive effect of foot-traffic. Therefore we recommend that you avoid bringing in this type of dirt, which comes in from the outside, by placing a door-mat at the entrance.
calibers (real size)	151x151 mm with 1 mm tolerance – 74,5x151 mm with 1 mm tolerance 74,5x74,5 mm on nets 304x304 mm with 1 mm tolerance – 36,25x36,25 mm on nets 304x304 with 1 mm tolerance



Scan the QR code to download the technical features in other languages

Colors

8 COLORS
2 FINISHES

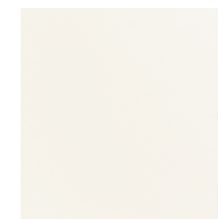

White Matt



White Glossy



Light Green Matt



Light Green Glossy

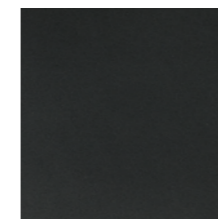

Black Matt

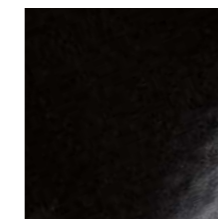

Black Glossy



Dark Green Matt



Dark Green Glossy



Light Blue Matt



Light Blue Glossy



Rose Matt



Rose Glossy

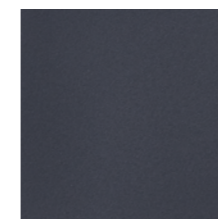

Dark Blue Matt



Dark Blue Glossy

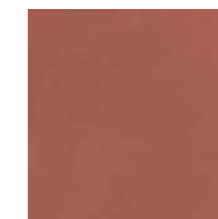

Red Matt



Red Glossy

For information about the available grouts, please contact the sales department.

Special Pieces

collection	Din
design	Konstantin Grcic, 2021
production	Artisanal
material	Glazed pressed, extruded and not rectified body
thickness	9 mm
nominal sizes	(A) 3,8x3,8x3,8 cm – (B) 4,5x4,5x4,5 cm – (C) 7,4x7,4x3,8 cm (D) 7,4x7,4x4,5 cm – (E) 3,8x3,8x15 cm – (F) 4,5x4,5x15 cm
specification	All the special pieces are available in all colors and finishes.
real sizes	(A) 39x39x39 mm +2 mm – (B) 45x45x45 mm +2 mm – (C) 74x74x39 mm +2 mm (D) 74x74x45 mm +2 mm – (E) 39x39x150,5 mm +2 mm – (F) 45x45x150,5 mm +2 mm

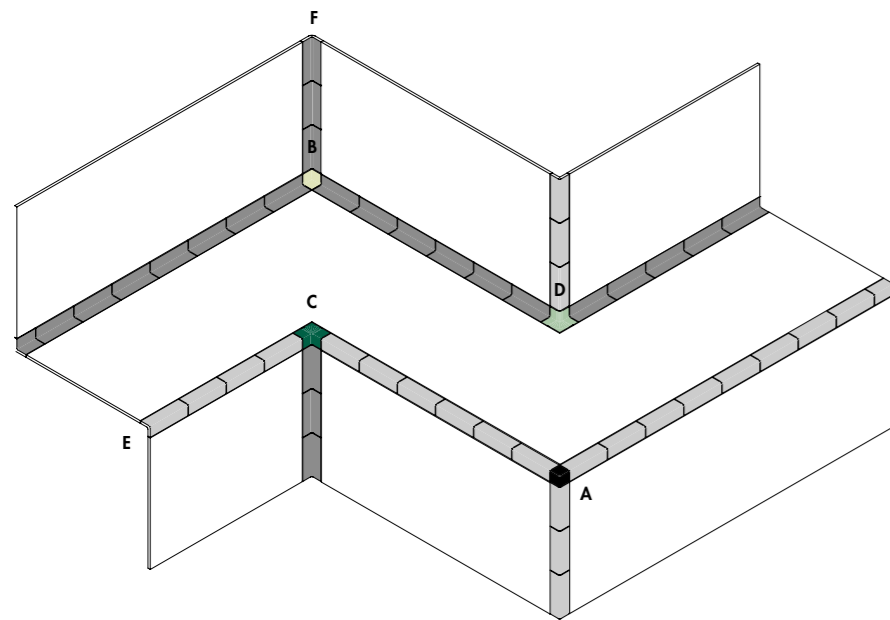
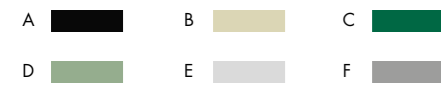
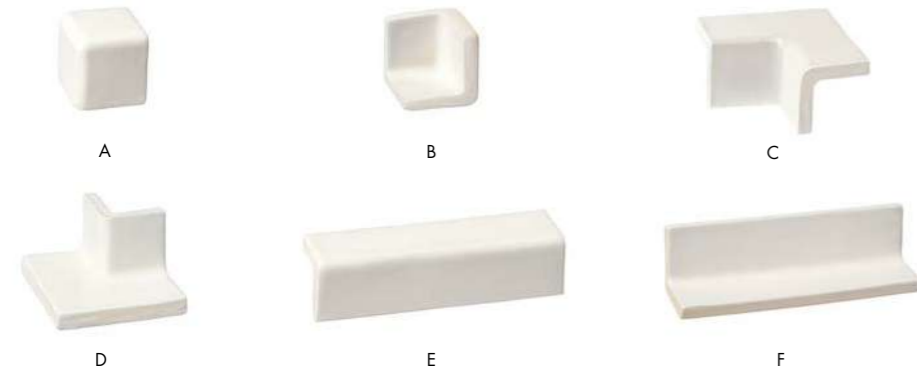

To obtain a correct aesthetic result check the actual measurements of both the volumes and the special pieces before installation. This is to align and adjust the pieces and the joint spacings to compensate possible differences in the calibres.

Technical features

STANDARD	FEATURES	VALUE REQUIRED	DIN
ISO 10545/3	water absorption	0,5<x<3%	2,5%
ISO 10545/4	breaking strength	Sp> 7,5 min 1100	resistant
ISO 10545/9	thermal shock resistance	no visible alteration	resistant
ISO 10545/12	frost resistance	no visible alteration	resistant
ISO 10545/13	resistance to chemical attacks	min B	A
ISO 10545/14	stains resistance	class 3	class 5
DIN 51130-04	slip resistance	–	R10 15x15 and 7,4x15 – Matt R11 30,2x30,2 on net – Matt
DIN 51097		–	B 15x15 and 7,4x15 – Matt C 30,2x30,2 on net – Matt
DCOF			>0.77 matt
BS 7976-2			53 dry – matt 38 wet – matt
VOC Emission			available upon request
Declaration of Contents			available upon request
EPD			available upon request
SDS			available upon request
Red List Building Materials			available upon request
BPD3			available upon request
HPD			available upon request

Packing

SIZE	PCS-SQM	PCS-BOX	SQM-BOX	BOX-PAL	KG-BOX	KG-PAL	SQM-PAL
15-15 cm	44,44	32	0,72	68	13,64	927,52	48,96
7,4-15 cm	88,88	64	0,72	68	13,64	927,52	48,96
net 30,2-30,2 cm (7,4-7,4 cm)	11	8	0,72	42	13,64	572,88	30,24
net 30,2-30,2 cm (3,6-7,4 cm)	11	8	0,72	42	13,64	572,88	30,24

Flow

collection	Flow
design	Mutina, 2010
production	Industrial
material	Unglazed homogeneous porcelain stoneware
features	Squared and rectified slabs each one exactly the same as the others
thickness	11 mm
nominal sizes	30-120 cm (12"-47") 15-120 cm (6"-47")
specification	A base color, full body colored: white- 3 special pieces: step, corner tile, skirting
complementary pieces	Step, Corner tile, Skirting
category	UNI EN 14411 App G (BIA group) UGL

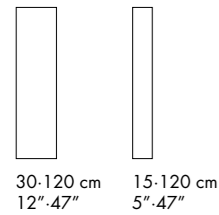

complementary pieces

step
30-120-4,5 cm
12"-47"-17/8"

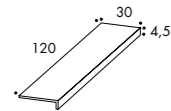

corner tile
30-120-4,5 cm
12"-47"-17/8"

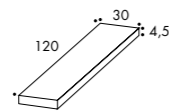

skirting
3,8-60 cm
2"-24"

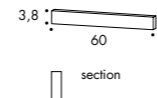

Scan the QR code to download the technical features in other languages

Laying and maintenance tips

use	Floor, wall – indoor, outdoor.
installation	For an even, smooth shading effect when laying, alternate material from several different boxes.
recommended adhesive	Adhesive for porcelain stoneware.
recommended joints	2mm joints. Use wedges to fix the caliber differences in work size between tiles.
recommended fillers	Cement-based grout / epoxy grout. Remove all traces of grout carefully before it dries completely.
cleaning at the end of installation	CEMENT-BASED GROUT: Buffered acid (e.g. DETERDEK PRO by FILA, or similar). Wet the floor with water, dilute the product 1:5 with water and pour it on the floor. Wait for 2 or 3 minutes then use a white scotch brite pad and rinse well with clean water. EPOXY GROUT: Alkaline detergent (e.g. FILA CR10 by FILA). FILA CR10: apply pure, wait for 30 minutes then use a green scotch brite pad. SILICONE: Solvent for silicone (e.g. FILA ZERO SIL.). Pour it straight onto the stain, wait for 20 minutes and remove the mark using scotch brite. PAINT: Can usually be removed using water, but if resin-based paints or particular enamels have been used, it is best to ask the manufacturer which solvent is most suitable. RUST: stain remover es. FILA NO RUST. Apply the product onto the stain, leave for 15 minutes, remove the residue and rinse thoroughly.
general cleaning (installed tiles)	You are recommended to use ordinary neutral detergent diluted in water. Avoid using acid or alkaline products, waxes and/or impregnants. During ordinary cleaning it is recommended to use extremely abrasive items (such as scourers and iron or steel sponges) as little as possible. This recommendation must be adhered to rigorously in the case of tiles with a glossy surface finishing as they are more susceptible to the risk of scuffs, scratches and loss of shine, etc. In the event of heavy dirt or particularly textured surfaces, use an alkaline detergent and rinse after washing. For large surfaces, the use of a floor washing machine is recommended. During every-day cleaning procedures, it is necessary to remember that certain types of dirt (dust, sand) increase the abrasive effect of foot-traffic. Therefore we recommend that you avoid bringing in this type of dirt, which comes in from the outside, by placing a door-mat at the entrance.
calibers (real size)	147 mm x 1195 mm 296,5 mm x 1195 mm

Colors

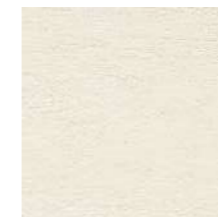

White

For information about the available grouts, please contact the sales department.

Technical features

STANDARD	FEATURES	VALUE REQUIRED	FLOW
ISO 10545/3	water absorption	< 0,5%	0,06%
ISO 10545/6	resistance to deep abrasion	<175 mm3	in conformity
ISO 10545/9	thermal shock resistance	no alteration	no alteration
ISO 10545/12	frost resistance	no alteration	no alteration
ISO 10545/13	acids and alkalis resistance	min B	A
ISO 10545/14	stains resistance	class 3	class 5
DIN 51130 - 04	slip resistance	medium values 6÷10° R9 10÷19° R10 19÷27° R11 27÷35° R12 > 35° R13	R10
DIN 51097	-	-	B
DCOF	-	-	-
LEED CERTIFICATION 4.1			25%
ENVIRONMENTAL MANAGEMENT SYSTEM ISO 14001 : 2004			
VOC Emission			available upon request
Declaration of Contents			available upon request
EPD			available upon request
SDS			available upon request
BPD3			available upon request
HPD			available upon request



Packing

SIZE	PCS-SQM	PCS-BOX	SQM-BOX	BOX-PAL	KG-BOX	KG-PAL	SQM-PAL
30-120 cm	2,78	3	1,08	48	26,00	1248,00	51,84
15-120 cm	5,55	6	1,08	22	25,25	555,00	23,76
step 30-120-4,5 cm	-	2	2,40 ml	-	21,20	-	-
corner tile 30-120-4,5 cm	-	1	1,20 ml	-	11,00	-	-
skirting - terminale 3,8-60 cm	-	10	6,00 ml	-	5,00	-	-



Scan the QR code to download the technical features in other languages

Folded

collection	Folded
design	Raw Edges, 2010
production	Industrial
material	Homogeneous porcelain stoneware
features	Squared and rectified slabs each one exactly the same as the others
thickness	10 mm
nominal sizes	60-60 cm (24"-24")
specification	The collection is: - 1 extra white color - 3 pattern, random in the box The base color is solid, full thickness body, using an extra white porcelain base
complementary pieces	Skirting
patents	registered design n° 001912999-011 - date of registration: 06/09/2011
category	UNI EN 14411 App G (BIA group) UGL

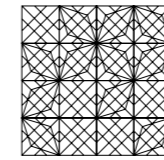

60-60 cm
(24"-24")

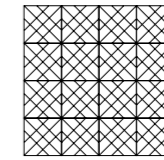
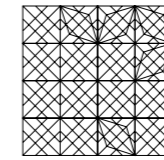

3 patterns randomly mixed into the box

complementary pieces

skirting
3,8-60 cm
2"-24"

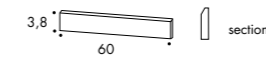

Laying and maintenance tips

use	Floor, wall – indoor, outdoor.
installation	For an even, smooth shading effect when laying, alternate material from several different boxes.
recommended adhesive	Adhesive for porcelain stoneware.
recommended joints	2mm joints. Use wedges to fix the caliber differences in work size between tiles.
recommended fillers	Cement-based grout / epoxy grout.
cleaning at the end of installation	CEMENT-BASED GROUT: Buffered acid (e.g. DETERDEK PRO by FILA, or similar). Wet the floor with water, dilute the product 1:5 with water and pour it on the floor. Wait for 2 or 3 minutes then use a white scotch brite pad and rinse well with clean water. EPOXY GROUT: Alkaline detergent (e.g. FILA CR10 by FILA). FILA CR10: apply pure, wait for 30 minutes then use a green scotch brite pad. SILICONE: Solvent for silicone (e.g. FILA ZERO SIL.). Pour it straight onto the stain, wait for 20 minutes and remove the mark using scotch brite. PAINT: Can usually be removed using water, but if resin-based paints or particular enamels have been used, it is best to ask the manufacturer which solvent is most suitable. RUST: stain remover es. FILA NO RUST. Apply the product onto the stain, leave for 15 minutes, remove the residue and rinse thoroughly.
general cleaning (installed tiles)	You are recommended to use ordinary neutral detergent diluted in water. Avoid using acid or alkaline products, waxes and/or impregnants. During ordinary cleaning it is recommended to use extremely abrasive items (such as scourers and iron or steel sponges) as little as possible. This recommendation must be adhered to rigorously in the case of tiles with a glossy surface finishing as they are more susceptible to the risk of scuffs, scratches and loss of shine, etc. In the event of heavy dirt or particularly textured surfaces, use an alkaline detergent and rinse after washing. For large surfaces, the use of a floor washing machine is recommended. During every-day cleaning procedures, it is necessary to remember that certain types of dirt (dust, sand) increase the abrasive effect of foot-traffic. Therefore we recommend that you avoid bringing in this type of dirt, which comes in from the outside, by placing a door-mat at the entrance.
calibers (real size)	600 mm x 600 mm

Colors



For information about the available grouts, please contact the sales department.

Technical features

STANDARD	FEATURES	VALUE REQUIRED	FOLDED
ISO 10545/3	water absorption	< 0,5%	in conformity
ISO 10545/6	resistance to deep abrasion	<175 mm3	in conformity
ISO 10545/9	thermal shock resistance	no alteration	no alteration
ISO 10545/12	frost resistance	no alteration	no alteration
ISO 10545/13	acids and alkalis resistance	min B	A
ISO 10545/14	stains resistance	classe 3	class 4
DIN 51130-04	slip resistance	medium values 6÷10° R9 10÷19° R10 19÷27° R11 27÷35° R12 > 35° R13	R9
DIN 51097		–	–
Pendulum BS 7976-2			51 dry 41 wet
LEED CERTIFICATION 4.1			15% recycled material
ISO 14001 - ISO 9001			
VOC Emission			available upon request
Declaration of Contents			available upon request
EPD			available upon request
SDS			available upon request
BPD3			available upon request
HPD			available upon request



Packing

SIZE	PCS-SQM	PCS-BOX	SQM-BOX	BOX-PAL	KG-BOX	KG-PAL	SQM-PAL
60-60 cm	2,77	3	1,08	40	22,85	914,00	43,20
skirting 3,8-60 cm	–	10	6,00 ml	–	5,00	–	–

Folded XL

collection	Folded XL
design	Raw Edges, 2017
production	Industrial
material	Unglazed homogeneous porcelain stoneware
features	Squared and rectified slabs each one exactly the same as the others
thickness	5,6 mm
nominal sizes	100-300 cm (39,4"-118")
specification	<ul style="list-style-type: none"> - 1 color - Extra white body of porcelain stoneware, without additions of glazes or colouring agents. - Pure ceramic clay pressed in a latest generation machine to obtain textured surfaces even on large slabs. - Rectified edges to allow a joint of just 2 mm. - Suitable for both floor and wall tiles, for indoor and outdoor use
patents	Registered design (tiles) n° 001912999-011 – date of registration: 06/09/2011
category	UNI EN 14411 App G (BIA group) UGL

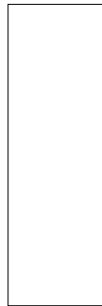

100-300 cm
39,4"-118"



Scan the QR code to download the technical features in other languages

Laying and maintenance tips

use	Floor, wall – indoor, outdoor.
installation	Check the flatness with a 2 metre long straight edge, by placing it on the screed in all directions. Maximum permissible tolerance 3 mm. Use specific self-levelling products if the difference is greater
recommended adhesive	For tiling a floor on substrates such as cement and anhydrite screed (after applying a primer), Class C2S2 cementitious adhesives are normally used for the largest format. On floor heating, even smaller formats must be laid with Class C2S2 cementitious adhesives. On pre-existing or old ceramic tiled floors, it is advisable to use quick-setting adhesives.
recommended joints	2mm joints. Use wedges to fix the caliber differences in work size between tiles.
recommended fillers	Cementitious grout / epoxy grout.
cleaning at the end of installation	CEMENT-BASED GROUT: Buffered acid (e.g. DETERDEK PRO by FILA, or similar). Wet the floor with water, dilute the product 1:5 with water and pour it on the floor. Wait for 2 or 3 minutes then use a white scotch brite pad and rinse well with clean water. EPOXY GROUT: Alkaline detergent (e.g. FILA CR10 by FILA). FILA CR10: apply pure, wait for 30 minutes then use a green scotch brite pad. SILICONE: Solvent for silicone (e.g. FILA ZERO SIL). Pour it straight onto the stain, wait for 20 minutes and remove the mark using scotch brite. PAINT: Can usually be removed using water, but if resin-based paints or particular enamels have been used, it is best to ask the manufacturer which solvent is most suitable. RUST: stain remover es. FILA NO RUST. Apply the product onto the stain, leave for 15 minutes, remove the residue and rinse thoroughly.
general cleaning (installed tiles)	You are recommended to use ordinary neutral detergent diluted in water. Avoid using acid or alkaline products, waxes and/or impregnants. During ordinary cleaning it is recommended to use extremely abrasive items (such as scourers and iron or steel sponges) as little as possible. This recommendation must be adhered to rigorously in the case of tiles with a glossy surface finishing as they are more susceptible to the risk of scuffs, scratches and loss of shine, etc. In the event of heavy dirt or particularly textured surfaces, use an alkaline detergent and rinse after washing. For large surfaces, the use of a floor washing machine is recommended. During every-day cleaning procedures, it is necessary to remember that certain types of dirt (dust, sand) increase the abrasive effect of foot-traffic. Therefore we recommend that you avoid bringing in this type of dirt, which comes in from the outside, by placing a door-mat at the entrance.
calibers (real size)	1000 mm x 3000 mm

Colors

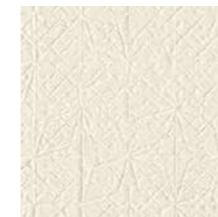

For information about the available grouts, please contact the sales department.

Technical features

STANDARD	FEATURES	VALUE REQUIRED	FOLDED XL
ISO 10545/2	SIZES		
	length and width	± 0,6%	in conformity with standard
	thickness	± 5%	
	straightness of edges	± 0,5%	
	wedging	± 0,5%	
	flatness	± 0,5%	
ISO 10545/3	water absorption	< 0,5%	in conformity with standard
ISO 10545/6	resistance to deep abrasion	≤ 175mm ³	in conformity with standard
ISO 10545/9	resistance to thermal shock	no visible alteration	resistant
ASTM C484		no samples must show visible defects	unaffected
ISO 10545/12	frost resistance	no visible alteration	resistant
ISO 10545/13	resistance to chemical attacks	no visible alteration	resistant
ISO 10545/14	stains resistance	class 3	class 5
DIN 51130-04	slip resistance	medium values 6÷10° R9 10÷19° R10 19÷27° R11 27÷35° R12 > 35° R13	R10
DIN 51097		–	–
DCOF		> 0,42	0,68
Pendulum AS/NSZ 4586-13			–
LEED CERTIFICATION 4.1			30% pre-consumer recycled material
ISO 14000 and ISO 9001			
Robinson Test		–	–
VOC Emission			available upon request
Declaration of Contents			available upon request
EPD			available upon request
SDS			available upon request
BPD3			available upon request
HPD			available upon request



Packing

SIZE	PCS-SQM	PCS-BOX	SQM-PC	PC-PAL	KG-PC	KG-PAL	SQM-PAL
100-300 cm	0,33	1	3	13	42,60	554,00	39,00



Scan the QR code to download the technical features in other languages

Kosei

collection	Kosei
design	Vincent Van Duysen, 2022
production	Industrial
material	Extruded unglazed porcelain stoneware
thickness	10 mm
nominal sizes	60x180 cm (24"x71"), 60x90 cm (24"x36"), 60x60 cm (24"x24"), 15x90 cm (6"x36"), 15x60 cm (6"x24"), 15x30 cm (6"x12"), 15x15 cm (6"x6") chevron: 9,6x56,5 cm (4"x22")
specification	– 5 colours: Bone, Storm, Terra, Grey Green, Dark Grey
category	UNI EN 14411 App A (A1 group) UGL

complementary pieces

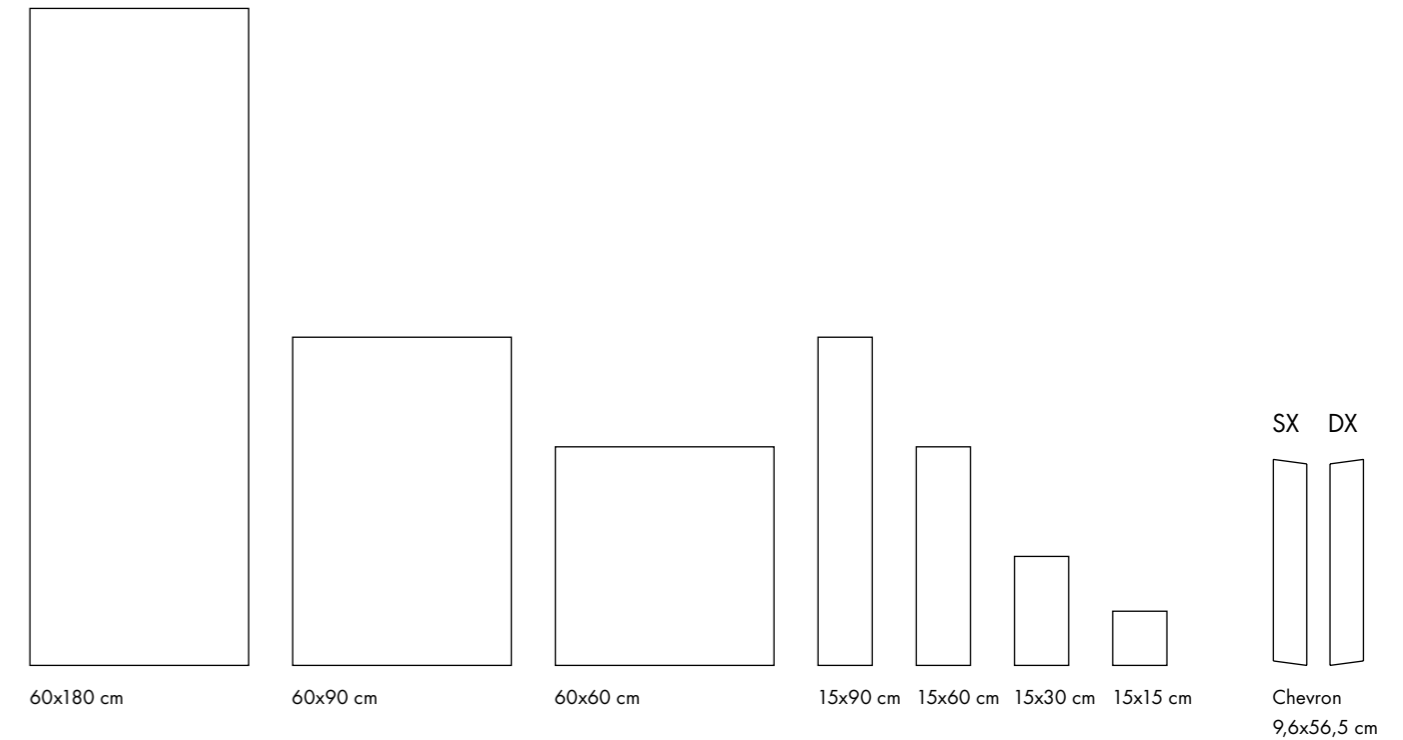
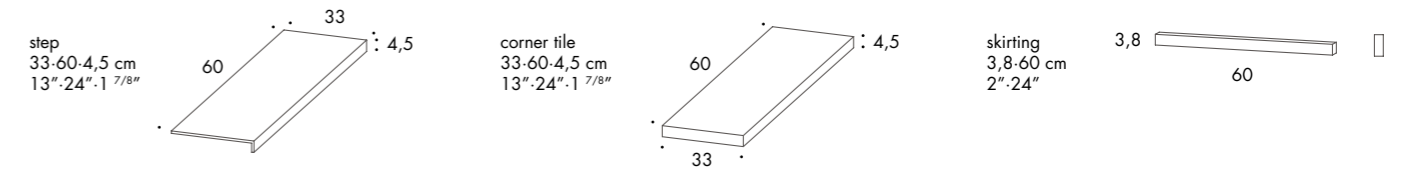

Laying and maintenance tips

use	Floors, walls – indoor, outdoor.
installation	The double spreading technique is recommended for the 60x180 size.
recommended adhesive	Adhesive for porcelain stoneware.
recommended joints	2mm joints.
recommended fillers	CEMENT-BASED GROUT / EPOXY GROUT. Remove all traces of grout carefully before it dries completely.
cleaning at the end of installation	CEMENT-BASED GROUT: Buffered acid (e.g. DETERDEK PRO by FILA or similar). Wet the floor with water, dilute the product 1:5 with water and pour it on the floor. Wait for 2-3 minutes then use a white scotch brite pad and rinse well with clean water. EPOXY GROUT: Alkaline detergent (e.g. FILA CR10 by FILA). FILA CR10: apply pure, wait for 30 minutes then use a green scotch brite pad. SILICONE: Solvent for silicone e.g. FILA ZERO SIL. Put it straight onto the stain, wait for 20 minutes and remove the mark using scotch brite. PAINT: Can usually be removed using water, but if resin-based paints or particular enamels have been used, it is best to ask the manufacturer which solvent is most suitable. RUST: stain remover es. FILA NO RUST. Apply the product onto the stain, leave for 15 minutes, remove the residue and rinse thoroughly.
general cleaning (installed tiles)	You are recommended to use ordinary neutral detergent diluted in water. Avoid using acid or alkaline products, waxes and/or impregnants. During ordinary cleaning it is recommended to use extremely abrasive items (such as scourers and iron or steel sponges) as little as possible. This recommendation must be adhered to rigorously in the case of tiles with a glossy surface finishing as they are more susceptible to the risk of scuffs, scratches and loss of shine, etc. In the event of heavy dirt or particularly textured surfaces, use an alkaline detergent and rinse after washing. For large surfaces, the use of a floor washing machine is recommended. During every-day cleaning procedures, it is necessary to remember that certain types of dirt (dust, sand) increase the abrasive effect of foot-traffic. Therefore we recommend that you avoid bringing in this type of dirt, which comes in from the outside, by placing a door-mat at the entrance.
calibers (real size)	59.8 x 179.8 cm 59.8 x 89.8 cm 59.8 x 59.8 cm 14.8 x 89.8 cm 14.8 x 59.8 cm 14.8 x 29.8 cm 14.8 x 14.8 cm

Colors



Bone



Storm

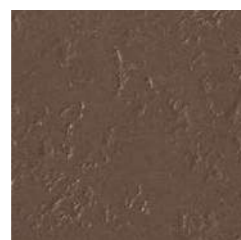

Terra

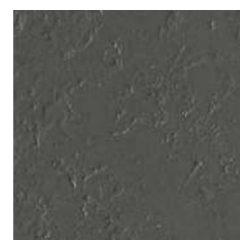

Grey Green



Dark Grey

Technical features

STANDARD	FEATURES	VALUE REQUIRED	KOSEI
ISO 10545/2	SIZES length and width thickness straightness of edges wedging flatness	± 1% ± 10% ± 0,5% ± 1% ± 0,5%/0,8%	in conformity with standard
ISO 10545/3	water absorption	< 0,5%	0,06%
ISO 10545/4	breaking strength modulus of rupture	≥ 1300 N ≥ 32 N/mm ²	in conformity with standard
ISO 10545/9	resistance to thermal shock	comply requirements	resistant
ISO 10545/12	frost resistance	comply requirements	resistant
ISO 10545/13	Resistance to acids and alkalis (low and high concentration) Resistance to household cleaning agents and swimming pool chemicals	declared value minimum class B	A A
ISO 10545/14	stains resistance	minimum 3	5
DIN 51130			R10
DIN 51097			B
DCOF		> 0.42	0.84
Pendulum BS (EN 16165-c)			55 dry 45 wet
Pendulum AS/NZS (4586313 app A)			44 P3
Pendulum ES (UNE 41901)			45 C2
ISO 14001			
VOC Emission Declaration of Contents EPD SVHC declaration			available upon request



Packing

SIZE	PCS-SQM	PCS-BOX	SQM-BOX	BOX-PAL	KG-BOX	KG-PAL	SQM-PAL
60-180 cm	0,93	1	1,08	48	25,20	1210	51,84
60-90 cm	1,85	2	1,08	48	25,20	1210	51,84
60-60 cm	2,78	2	0,72	64	16,80	1075	46,10
15-90 cm	7,41	6	0,81	51	18,90	964	41,31
15-60 cm	11,11	9	0,81	52	18,90	983	42,12
15-30 cm	22,22	18	0,81	52	18,90	983	42,12
15-15 cm	44,44	36	0,81	52	18,90	983	42,12
chevron 9,6-56,5	18,44	14	0,76	45	17,70	797	34,20
step 33-60-4,5 cm	-	2	1,20	-	13,00	-	-
corner tile 33-60-4,5 cm	-	1	0,60	-	6,50	-	-
skirting 3,8-60 cm	-	10	6 ml	-	5,00	-	-

Lane

collection	Lane
design	Edward Barber & Jay Osgerby, 2018
production	Industrial
material	Glazed porcelain stoneware
thickness	8,5 mm
sizes	7,9·16 cm (37/64"·619/64")
specification	<ul style="list-style-type: none"> - 3 styles: Base, Mono, Poly - 5 surface textures random mixed - Base comprises 5 colour palettes: White (9 shades, 5 textures), Grey (5 shades, 5 textures), Black (5 shades, 5 textures), Terracotta (10 shades, 5 textures), Aubergine (10 shades, 5 textures) - Poly comprises the 5 "Base" colors plus a number of elements in contrast - Mono: Black and White only
awards	Best reflective space - Wallpaper Design Award 2019
patents	Registered design n° 006336608-0001/0037 – date of registration: 26/03/2019
category	UNI EN 14411 App G (BIA group) GL



7,9·16 cm
(37/64"·619/64")

Laying and maintenance tips

use	Floor, wall – indoor, outdoor.
installation	The material is deliberately shaded. Take the material from several boxes and mix carefully.
recommended adhesive	Adhesive for porcelain stoneware.
recommended joints	2mm joints. Use wedges to fix the caliber differences in work size between tiles.
recommended fillers	Cement-based grout / epoxy grout.
cleaning at the end of installation	<p>CEMENT-BASED GROUT: Buffered acid (e.g. DETERDEK PRO by FILA, or similar). Wet the floor with water, dilute the product 1:5 with water and pour it on the floor. Wait for 2 or 3 minutes then use a white scotch brite pad and rinse well with clean water.</p> <p>EPOXY GROUT: Alkaline detergent (e.g. FILA CR10 by FILA). FILA CR10: apply pure, wait for 30 minutes then use a green scotch brite pad.</p> <p>SILICONE: Solvent for silicone (e.g. FILA ZERO SIL). Pour it straight onto the stain, wait for 20 minutes and remove the mark using scotch brite.</p> <p>PAINT: Can usually be removed using water, but if resin-based paints or particular enamels have been used, it is best to ask the manufacturer which solvent is most suitable.</p> <p>RUST: stain remover es. FILA NO RUST. Apply the product onto the stain, leave for 15 minutes, remove the residue and rinse thoroughly.</p>
general cleaning (installed tiles)	You are recommended to use ordinary neutral detergent diluted in water. Avoid using acid or alkaline products, waxes and/or impregnants. During ordinary cleaning it is recommended to use extremely abrasive items (such as scourers and iron or steel sponges) as little as possible. This recommendation must be adhered to rigorously in the case of tiles with a glossy surface finishing as they are more susceptible to the risk of scuffs, scratches and loss of shine, etc. In the event of heavy dirt or particularly textured surfaces, use an alkaline detergent and rinse after washing. For large surfaces, the use of a floor washing machine is recommended. During every-day cleaning procedures, it is necessary to remember that certain types of dirt (dust, sand) increase the abrasive effect of foot-traffic. Therefore we recommend that you avoid bringing in this type of dirt, which comes in from the outside, by placing a door-mat at the entrance.
calibers (real size)	7,9 x 16 cm with 2 mm tolerance



Scan the QR code to download the technical features in other languages

Colors

BASE



Base White



Base Black



Base Grey



Base Aubergine



Base Terracotta

POLY



Poly White



Poly Black



Poly Grey



Poly Aubergine



Poly Terracotta

MONO



Mono White



Mono Black

For information about the available grouts, please contact the sales department.

Technical features

STANDARD	FEATURES	VALUE REQUIRED	LANE	
ISO 10545/3	water absorption	< 0,5%	in conformity with standard	
ISO 10545/4	breaking strength	≥ 1300 N	in conformity with standard	
	modulus of rupture	≥ 32 N/mm ²	in conformity with standard	
ISO 10545/9	resistance to thermal shock	no visible alteration	resistant	
ISO 10545/12	frost resistance	no visible alteration	resistant	
ISO 10545/13	resistance to acids and alkalis (low and high concentration)	declared value	A A	
	resistance to household cleaning agents and swimming pool chemicals	minimum class B	A A	
ISO 10545/14	stains resistance	minimum 3	4-5	
DIN 51130 - 04	slip resistance	medium values	R10	
		6÷10°		R9
		10÷19°		R10
		19÷27°		R11
		27÷35°		R12
> 35°	R13			
DIN 51097 - 04			B	
DCOF		> 0,42	0,61	
LEED CERTIFICATION 4.1		–	39% recycled material	
Robinson Test		–	moderate use	
VOC Emission			available upon request	
Declaration of Contents			available upon request	
SDS			available upon request	
BPD3			available upon request	
HPD			available upon request	



Packing

SIZE	PCS-SQM	PCS-BOX	SQM-BOX	BOX-PAL	KG-BOX	KG-PAL	SQM-PAL
7,9-16 cm	79,11	76	0,96	56	18,70	1047,20	53,76



Scan the QR code to download the technical features in other languages

Mattonelle Margherita

collection	Mattonelle Margherita
design	Nathalie Du Pasquier, 2020
production	Industrial
material	Glazed porcelain stoneware
thickness	10 mm
nominal sizes	Margherita Patterns, Margherita Plain Colors 20,5-20,5 cm (8"-8") Margherita Half 20,5-10,1 cm (8"-4")
specification	– 6 base colors in 20,5-20,5 cm – 27 graphic patterns in 20,5-20,5 cm – 8 half in 10,1-20,5 cm – Semi-gloss, silky surface
anti-slip	Special treatment is available upon request, at extra charge
awards	Interior Design Magazine's Best of Year Awards 2021 in the Category Tile + Stone Flooring
patent	Registered design n° 008171615-0001/0067 – date of registration: 30.09.2020
category	Bla UNI EN 14411 (GL)

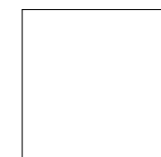

20,5-20,5 cm
8"-8"



20,5-10,1 cm
8"-4"

Laying and maintenance tips

use	Floor, wall – indoor, outdoor.
installation	For an even, smooth shading effect when laying, alternate material from several different boxes.
recommended adhesive	Adhesive for porcelain stoneware.
recommended joints	2mm joints.
recommended fillers	Cement-based grout / epoxy grout.
cleaning at the end of installation	CEMENT-BASED GROUT: Buffered acid (e.g. DETERDEK PRO by FILA or similar). Wet the floor with water, dilute the product 1:5 with water and pour it on the floor. Wait for 2-3 minutes then use a white scotch brite pad and rinse well with clean water. EPOXY GROUT: Alkaline detergent (e.g. FILA CR10 by FILA). FILA CR10: apply pure, wait for 30 minutes then use a green scotch brite pad. SILICONE: Solvent for silicone e.g. FILA ZERO SIL. Put it straight onto the stain, wait for 20 minutes and remove the mark using scotch brite. PAINT: Can usually be removed using water, but if resin-based paints or particular enamels have been used, it is best to ask the manufacturer which solvent is most suitable. RUST: stain remover es. FILA NO RUST. Apply the product onto the stain, leave for 15 minutes, remove the residue and rinse thoroughly.
general cleaning (installed tiles)	You are recommended to use ordinary neutral detergent diluted in water. Avoid using acid or alkaline products, waxes and/or impregnants. During ordinary cleaning it is recommended to use extremely abrasive items (such as scourers and iron or steel sponges) as little as possible. This recommendation must be adhered to rigorously in the case of tiles with a glossy surface finishing as they are more susceptible to the risk of scuffs, scratches and loss of shine, etc. In the event of heavy dirt or particularly textured surfaces, use an alkaline detergent and rinse after washing. For large surfaces, the use of a floor washing machine is recommended. During every-day cleaning procedures, it is necessary to remember that certain types of dirt (dust, sand) increase the abrasive effect of foot-traffic. Therefore we recommend that you avoid bringing in this type of dirt, which comes in from the outside, by placing a door-mat at the entrance.
calibers (real size)	20,5x20,5 : cal 1 : from 203,6x203,6 to 205x205 - cal 0 : from 202,1x202,1 to 203,5x203,5 20,5x10,1 : cal 1 : from 101,2x203,6 to 101,2x205 - cal 0 : from 100,4x202,1 to 100,4x203,5 (calibers depend on the production lot, we recommend to ask in advance)

Colors

27 PATTERNS
20,5X20,5 CM



Square Blue



Square Green

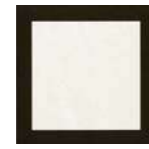

Square Black



Square Orange

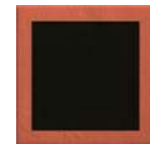

Square Terracotta



Double Blue



Double White



Double Red



Cones



Star

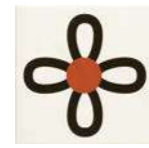

Petals



Corners



Scheme



Point



Rhombus White



Rhombus Black



Flower Green



Flower Black



Kite White



Kite Black



Spring Terracotta



Spring Pink



Black Green



Black Terracotta



Line



Stripes

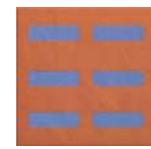

Signs

6 PLAIN COLORS
20,5X20,5 CM



Marghe White



Marghe Black



Marghe Terracotta



Marghe Green



Marghe Blue



Marghe Light Blue

8 HALF
10,1X20,5 CM



Marghe Half White



Marghe Half Black



Frame Black



Frame Terracotta



Street



Wires



Parallel Black



Parallel Orange

For information about the available grouts, please contact the sales department.

Technical features

STANDARD	FEATURES	VALUE REQUIRED	MATTONELLE MARGHERITA
ISO 10545/3	water absorption	< 0,5%	0,06%
ISO 10545/4	breaking strength	Sp> 7,5 min 1300	resistant
ISO 10545/9	thermal shock resistance	no alteration	no alteration
ISO 10545/12	frost resistance	no alteration	no alteration
ISO 10545/13	acids and alkalis resistance	min B	A
ISO 10545/14	stains resistance	class 3	class 5
DIN 51130-04	slip resistance	–	R11 antislip
DIN51097-04	slip resistance	–	B antislip
DCOF	slip resistance	–	0,85 antislip
Pendulum BS 7976-2:2002/A1:2013		–	62 dry antislip 52 wet antislip
LEED 4.1		–	20% recycled material
Robinson Test		–	heavy use
VOC Emission			available upon request
Declaration of Contents			available upon request
EPD			available upon request
SDS			available upon request
BPD3			available upon request
HPD			available upon request

Packing

SIZE	PCS-SQM	PCS-BOX	SQM-BOX	BOX-PAL	KG-BOX	KG-PAL	SQM-PAL
20,5-20,5 cm	23,88	16	0,67	48	14,20	681,60	32,16
10,1-20,5 cm	47,76	32	0,67	48	14,20	681,60	32,16

Mews

collection	Mews
design	Edward Barber & Jay Osgerby, 2013
production	Industrial
material	Glazed homogeneous porcelain stoneware
features	Cut pieces each one exactly the same as the others
thickness	10 mm
nominal sizes	5,5-45 cm (2".18") 11-11 cm (4".4") chevron 5,5-39,4 cm (2".16") chevron 5,5-19,6 cm (2".8")
specification	- 6 Colors - Each color composed by a random mix of 15 shades to obtain a softly shaded surface
complementary pieces	Step, Corner tile, Skirting
awards	Wallpaper Design Award 2014, Edida 2014
patents	Registered design n° 002336909-0005/0012 - date of registration: 31/10/2013
category	UNI EN 14411 App G (BIA group)

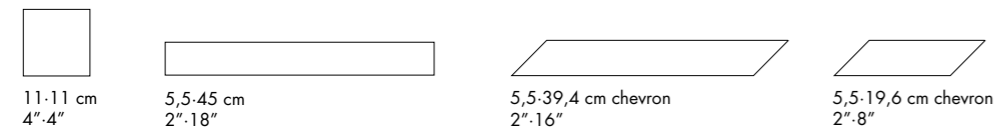

complementary pieces

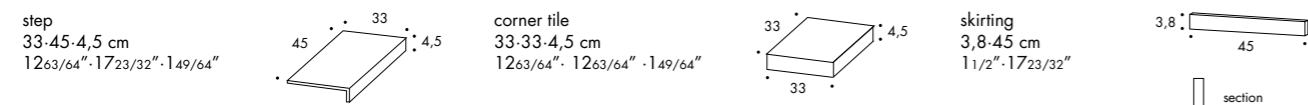

Scan the QR code to download the technical features in other languages

Laying and maintenance tips

use	Floor, wall - indoor, outdoor.
installation	The material is deliberately shaded. Take the material from several boxes and mix carefully.
recommended adhesive	Adhesive for porcelain stoneware.
recommended joints	2mm joints. Use wedges to fix the caliber differences in work size between tiles.
recommended fillers	Cement-based grout / epoxy grout.
cleaning at the end of installation	CEMENT-BASED GROUT: Buffered acid (e.g. DETERDEK PRO by FILA, or similar). Wet the floor with water, dilute the product 1:5 with water and pour it on the floor. Wait for 2 or 3 minutes then use a white scotch brite pad and rinse well with clean water. EPOXY GROUT: Alkaline detergent (e.g. FILA CR10 by FILA). FILA CR10: apply pure, wait for 30 minutes then use a green scotch brite pad. SILICONE: Solvent for silicone (e.g. FILA ZERO SIL.). Pour it straight onto the stain, wait for 20 minutes and remove the mark using scotch brite. PAINT: Can usually be removed using water, but if resin-based paints or particular enamels have been used, it is best to ask the manufacturer which solvent is most suitable. RUST: stain remover es. FILA NO RUST. Apply the product onto the stain, leave for 15 minutes, remove the residue and rinse thoroughly.
general cleaning (installed tiles)	You are recommended to use ordinary neutral detergent diluted in water. Avoid using acid or alkaline products, waxes and/or impregnants. During ordinary cleaning it is recommended to use extremely abrasive items (such as scourers and iron or steel sponges) as little as possible. This recommendation must be adhered to rigorously in the case of tiles with a glossy surface finishing as they are more susceptible to the risk of scuffs, scratches and loss of shine, etc. In the event of heavy dirt or particularly textured surfaces, use an alkaline detergent and rinse after washing. For large surfaces, the use of a floor washing machine is recommended. During every-day cleaning procedures, it is necessary to remember that certain types of dirt (dust, sand) increase the abrasive effect of foot-traffic. Therefore we recommend that you avoid bringing in this type of dirt, which comes in from the outside, by placing a door-mat at the entrance.
calibers (real size)	5,5 x 45 (linear) - 53 mm x 447 mm 5,3 x 39,4 (chevron) - 53 mm x 393 mm 5,5 x 19,6 (chevron) - 53 mm x 192 mm 11 x 11 (square) - 109 mm x 109 mm

Colors



Chalk

Fog

Pigeon

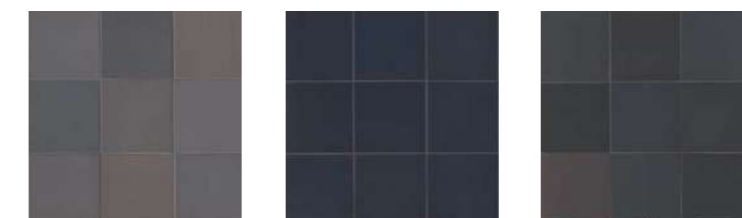

Lead

Ink

Soot

For information about the available grouts, please contact the sales department.

Technical features

STANDARD	FEATURES	VALUE REQUIRED	MEWS
ISO 10545/3	water absorption	< 0,5%	0,04%
ASTM C373		< 0,5%	0,04%
ISO 10545/4	breaking strength	Sp> 7,5 min 1300	resistant
ISO 10545/9	resistance to thermal shock	no visible alteration	resistant
ASTM C484		no samples must show visible defects	unaffected
ISO 10545/12	frost resistance	no visible alteration	resistant
ASTM C1026		unaffected	unaffected
ISO 10545/13	resistance to chemical attacks	no visible alteration	resistant
ASTM C650			unaffected
ISO 10545/14	stains resistance	class 3	class 5
DIN 51130 - 04	slip resistance	medium values 6±10° R9 10±19° R10 19±27° R11 27±35° R12 > 35° R13	R10
DIN 51097		–	–
DCOF		> 0,42	0,80
Pendulum BS7976-2		–	55 dry / 46 wet
LEED CERTIFICATION 4.1		–	13,8% - 15,3%
Robinson Test			heavy use
ISO 9001 - ISO 14001			
VOC Emission			available upon request
Declaration of Contents			available upon request
SDS			available upon request
EPD			available upon request
BPD3			available upon request
HPD			available upon request



Packing

SIZE	PCS-SQM	PCS-BOX	SQM-BOX	BOX-PAL	KG-BOX	KG-PAL	SQM-PAL
5,5-39,4 cm chevron	46,15	36	0,78	40	17,55	702,00	31,20
5,5-19,6 cm chevron	92,76	72	0,78	40	17,40	696,00	31,20
5,5-45 cm	40,40	36	0,89	40	20,20	808,00	35,60
11-11 cm	82,64	60	0,73	48	16,70	802,00	35,04
step 33-45-4,5 cm	–	2	0,90 ml	–	8,00	–	–
corner tile 33-33-4,5 cm	–	1	0,33 ml	–	6,10	–	–
skirting 3,8-45 cm	–	10	4,50 ml	–	3,65	–	–



Scan the QR code to download the technical features in other languages

Phenomenon

Phenomenon Rain

collection	Phenomenon
design	Tokujin Yoshioka, 2010 – 2013 – 2022
production	Artisanal
material	Homogeneous unglazed porcelain stoneware straws, obtained by pressing and fixed on net
thickness	RAIN A: min 5 mm - max 7 mm RAIN B: min 5 mm - max 7 mm RAIN C: 5 mm
nominal sizes	RAIN A: net 25-30 cm (net 9 7/8"·12") RAIN B: net 25-30 cm (net 9 7/8"·12") RAIN C: net 25-30 cm (net 9 7/8"·12")
specification	– 7 colours: Bianco, Grigio, Fango, Nero, Blu, Verde, Rosa – 3 mosaic card shapes on net – The mosaic is assembled in sheets to give a "handmade look" to the surface. Rain A-B-C, Honeycomb A-B, Rock, Air, Wind, of the series Phenomenon represent the finest of modern-day Italian craftsmanship. – Each mosaic card is individually pressed with a bespoke 100-holes mould, expressly created to achieve a materic and artisanal feeling, then fired through a bespoke, patented, process. – Mutina patented production process and machines (Industrial Patent filed on 02/09/2010 under number MO2010A000247) – The cards are manually assembled accurately by expert hands to build a unique, innovative pattern.
awards	ICFF Editors Award Material 2011, Wallpaper Design Award 2011, Edida 2011, Selected for Adi Design Index 2011, Love Tag Azure Magazine 2012, Red Dot Design Award 2012, Interior Innovation Award 2014, Best of Best 2014
patents	Registered design n° 001912999-0011 – date of registration: 06/09/2011
category	UNI EN 14411 App G (BIA group) UGL

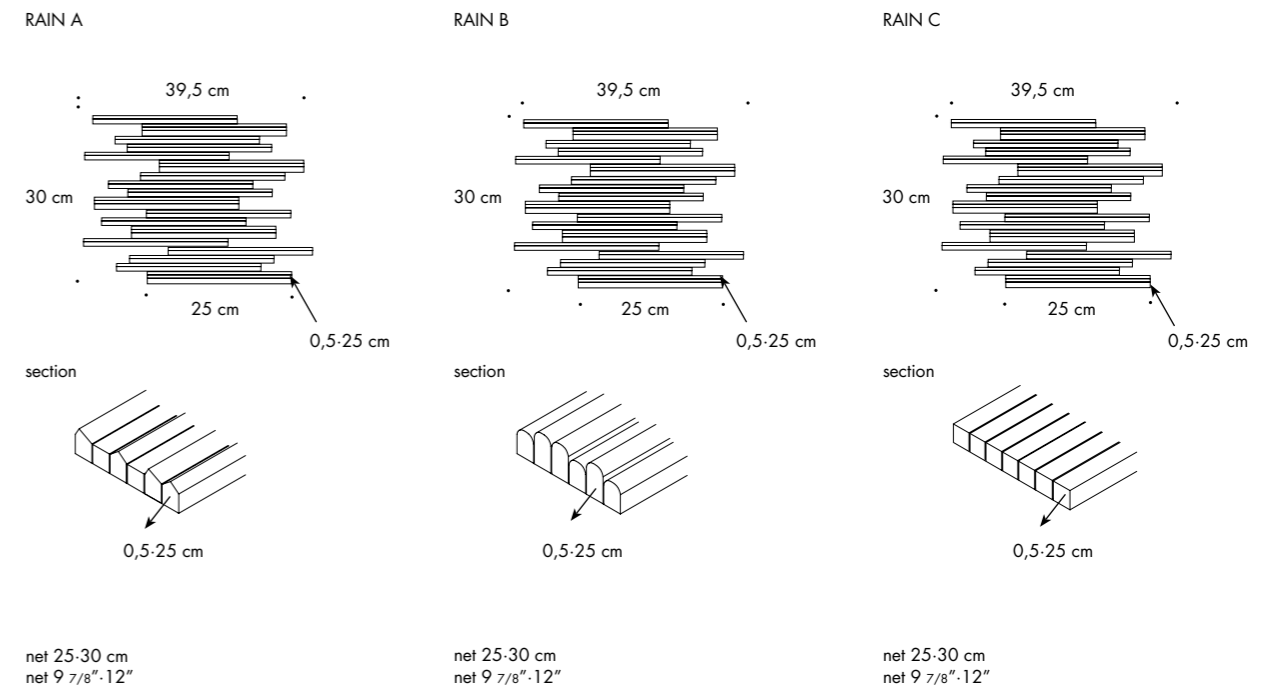

Laying and maintenance tips

use	Wall (RAIN A-B-C) – indoor, outdoor.
installation	Lay on perfectly flat, dry walls.
recommended adhesive	NON-RAPID-DRYING adhesive for porcelain stoneware to make it easier to fix the sheets.
recommended joints	2mm joints.
recommended fillers	CEMENT-BASED GROUT: (all mosaics). Grout 0.5 m ² at a time and wash thoroughly with clean water. Remove all traces of grout carefully before it dries completely. EPOXY GROUT: (rock, honey A only). Grout 0.5 m ² at a time and wash thoroughly with clean water. Remove all traces of grout carefully before it dries completely.
cleaning at the end of installation	CEMENT-BASED GROUT: Buffered acid (e.g. DETERDEK PRO by FILA, or similar). Wet the floor with water, dilute the product 1:5 with water and pour it on the floor. Wait for 2 or 3 minutes then use a white scotch brite pad and rinse well with clean water. EPOXY GROUT: Alkaline detergent (e.g. FILA CR10 by FILA). FILA CR10: apply pure, wait for 30 minutes then use a green scotch brite pad. SILICONE: Solvent for silicone (e.g. FILA ZERO SIL). Pour it straight onto the stain, wait for 20 minutes and remove the mark using scotch brite. PAINT: Can usually be removed using water, but if resin-based paints or particular enamels have been used, it is best to ask the manufacturer which solvent is most suitable. RUST: stain remover es. FILA NO RUST. Apply the product onto the stain, leave for 15 minutes, remove the residue and rinse thoroughly.
general cleaning (installed tiles)	You are recommended to use ordinary neutral detergent diluted in water. Avoid using acid or alkaline products, waxes and/or impregnants. During ordinary cleaning it is recommended to use extremely abrasive items (such as scourers and iron or steel sponges) as little as possible. This recommendation must be adhered to rigorously in the case of tiles with a glossy surface finishing as they are more susceptible to the risk of scuffs, scratches and loss of shine, etc. In the event of heavy dirt or particularly textured surfaces, use an alkaline detergent and rinse after washing.
calibers (real size)	–

Colors

RAIN A



Rain A Bianco



Rain A Grigio



Rain A Fango



Rain A Nero



Rain A Blu

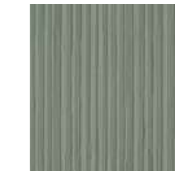

Rain A Verde



Rain A Rosa

RAIN B



Rain B Bianco



Rain B Grigio



Rain B Fango



Rain B Nero



Rain B Blu



Rain B Verde



Rain B Rosa

RAIN C



Rain C Bianco



Rain C Grigio



Rain C Fango



Rain C Nero



Rain C Blu



Rain C Verde



Rain C Rosa

For information about the available grouts, please contact the sales department.

Mosaics: Honeycomb, Rock, Air, Wind

collection	Phenomenon
design	Tokujin Yoshioka, 2010 - 2013 - 2022
production	Artisanal
material	Homogeneous unglazed porcelain stoneware tesserae, obtained by pressing and fixed on net
thickness	HONEYCOMB A: min 5 mm - max 6 mm HONEYCOMB B: min 6 mm - max 8 mm ROCK: 5 mm AIR: 8 mm WIND: 7 mm
nominal sizes	HONEYCOMB A: net 30-30 cm (net 12"-12") HONEYCOMB B: net 30-30 cm (net 12"-12") ROCK: net 29-29 cm (net 11 13/16"-11 13/16") AIR: net 30-30 cm (net 12"-12") WIND: net 25-25 cm (net 10"-10")
specification	<ul style="list-style-type: none"> - 7 colours: Bianco, Grigio, Fango, Nero, Blu, Verde, Rosa - 5 mosaic card shapes on net - The mosaic is assembled in sheets to give a "handmade look" to the surface. Rain A-B-C, Honeycomb A-B, Rock, Air, Wind, of the series Phenomenon represent the finest of modern-day Italian craftsmanship. - Each mosaic card is individually pressed with a bespoke 100-holes mould, expressly created to achieve a materic and artisanal feeling, then fired through a bespoke, patented, process. - Mutina patented production process and machines (Industrial Patent filed on 02/09/2010 under number MO2010A000247) - The cards are manually assembled accurately by expert hands to build a unique, innovative pattern.
awards	ICFF Editors Award Material 2011, Wallpaper Design Award 2011, Edida 2011, Selected for Adi Design Index 2011, Love Tag Azure Magazine 2012, Red Dot Design Award 2012, Interior Innovation Award 2014, Best of Best 2014
patents	Registered design n° 001912999-0011 - date of registration: 06/09/2011 Registered design n° 002336909-0001/0004 - date of registration: 31/10/2013
category	UNI EN 14411 App G (BIA group) UGL

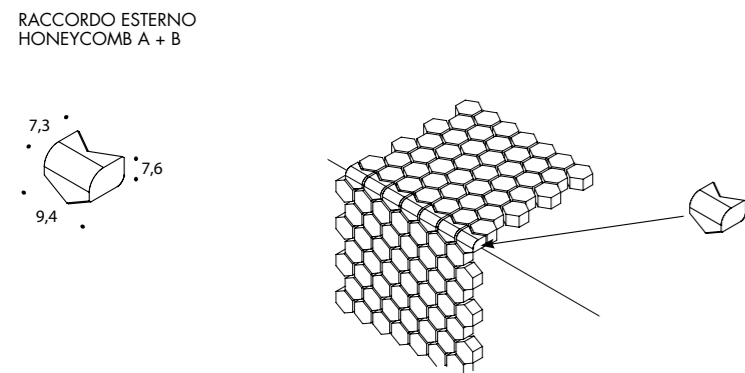
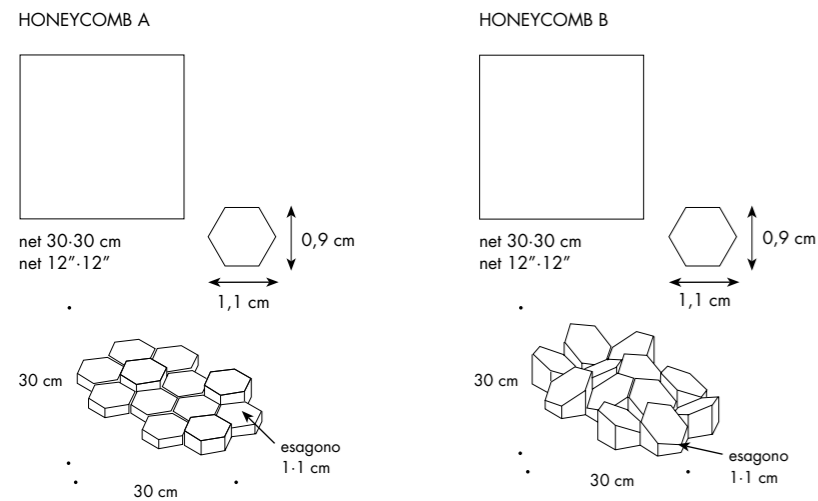

ROCK



net 29-29 cm
net 11 13/16"-11 13/16"

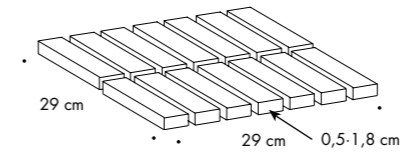

AIR

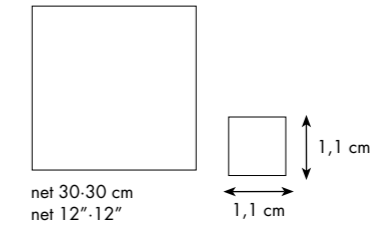

net 30-30 cm
net 12"-12"

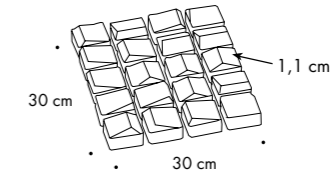

WIND

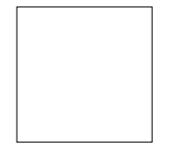

net 25-25 cm
net 10"-10"

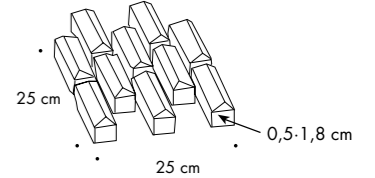

Laying and maintenance tips

use	Floor (ROCK, HONEYCOMB A), wall (ROCK, HONEYCOMB A, WIND, AIR, HONEYCOMB B) - indoor, outdoor.
installation	Lay on perfectly flat, dry walls.
recommended adhesive	NON-RAPID-DRYING adhesive for porcelain stoneware to make it easier to fix the sheets.
recommended joints	2mm joints.
recommended fillers	CEMENT-BASED GROUT: (all mosaics). Grout 0.5 m ² at a time and wash thoroughly with clean water. Remove all traces of grout carefully before it dries completely. EPOXY GROUT: (rock, honeycomb A only). Grout 0.5 m ² at a time and wash thoroughly with clean water. Remove all traces of grout carefully before it dries completely.
cleaning at the end of installation	CEMENT-BASED GROUT: Buffered acid (e.g. DETERDEK PRO by FILA, or similar). Wet the floor with water, dilute the product 1:5 with water and pour it on the floor. Wait for 2 or 3 minutes then use a white scotch brite pad and rinse well with clean water. EPOXY GROUT: Alkaline detergent (e.g. FILA CR10 by FILA). FILA CR10: apply pure, wait for 30 minutes then use a green scotch brite pad. SILICONE: Solvent for silicone (e.g. FILA ZERO SIL.). Pour it straight onto the stain, wait for 20 minutes and remove the mark using scotch brite. PAINT: Can usually be removed using water, but if resin-based paints or particular enamels have been used, it is best to ask the manufacturer which solvent is most suitable. RUST: stain remover es. FILA NO RUST. Apply the product onto the stain, leave for 15 minutes, remove the residue and rinse thoroughly.
general cleaning (installed tiles)	You are recommended to use ordinary neutral detergent diluted in water. Avoid using acid or alkaline products, waxes and/or impregnants. During ordinary cleaning it is recommended to use extremely abrasive items (such as scourers and iron or steel sponges) as little as possible. This recommendation must be adhered to rigorously in the case of tiles with a glossy surface finishing as they are more susceptible to the risk of scuffs, scratches and loss of shine, etc. In the event of heavy dirt or particularly textured surfaces, use an alkaline detergent and rinse after washing. For large surfaces, the use of a floor washing machine is recommended. During every-day cleaning procedures, it is necessary to remember that certain types of dirt (dust, sand) increase the abrasive effect of foot-traffic. Therefore we recommend that you avoid bringing in this type of dirt, which comes in from the outside, by placing a door-mat at the entrance.
calibers (real size)	-

Colors

HONEYCOMB A

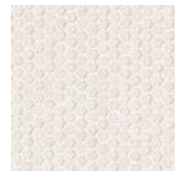

Honeycomb A Bianco

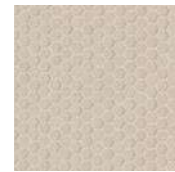

Honeycomb A Grigio

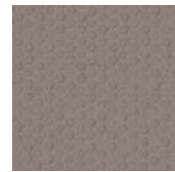

Honeycomb A Fango



Honeycomb A Nero

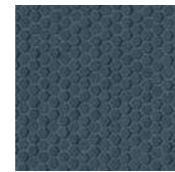

Honeycomb A Blu

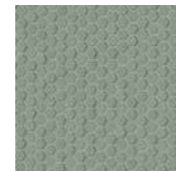

Honeycomb A Verde



Honeycomb A Rosa

HONEYCOMB B

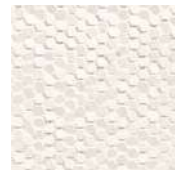

Honeycomb B Bianco

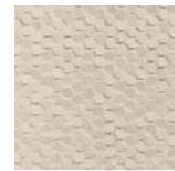

Honeycomb B Grigio



Honeycomb B Fango



Honeycomb B Nero

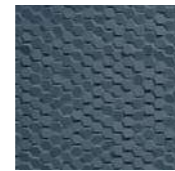

Honeycomb B Blu

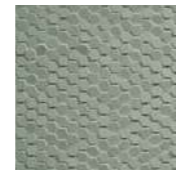

Honeycomb B Verde



Honeycomb B Rosa

ROCK

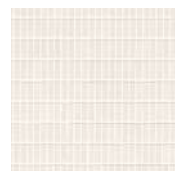

Rock Bianco



Rock Grigio

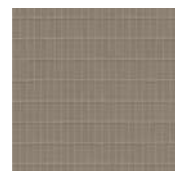

Rock Fango

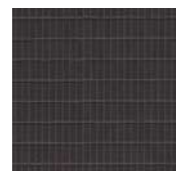

Rock Nero

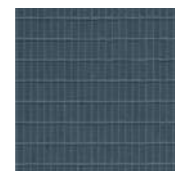

Rock Blu

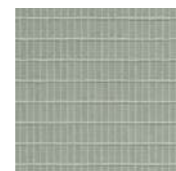

Rock Verde

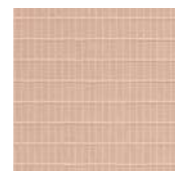

Rock Rosa

AIR



Air Bianco

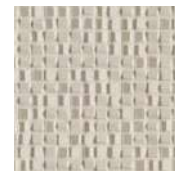

Air Grigio

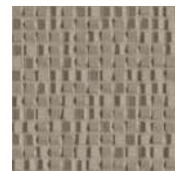

Air Fango

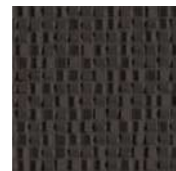

Air Nero

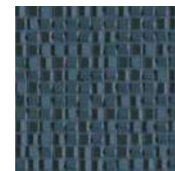

Air Blu

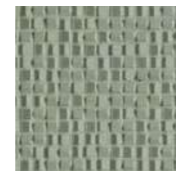

Air Verde

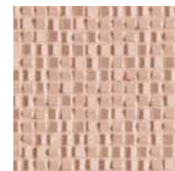

Air Rosa

WIND



Wind Bianco



Wind Grigio



Wind Fango

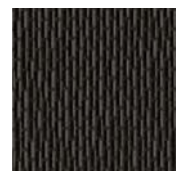

Wind Nero



Wind Blu



Wind Verde

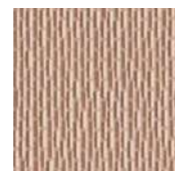

Wind Rosa

Phenomenon Glossy: Rain A, Honeycomb B, Rock

collection	Phenomenon Glossy
design	Tokujin Yoshioka, 2022
production	Artisanal
material	Homogeneous glazed porcelain stoneware tesserae and straws, obtained by pressing and fixed on net
thickness	RAIN A: MIN 5 mm - MAX 7 mm HONEYCOMB B: min 6 mm - max 8 mm ROCK: 5 mm
nominal sizes	HONEYCOMB B, - 30X30 sheet ROCK - 29X29 sheet RAIN A - 25X30 sheet
specification	- 4 colours: Bianco Glossy, Nero Glossy, Oro, Argento - 3 mosaic card shapes on net - The mosaic is assembled in sheets to give a "handmade look" to the surface. Rain A, Honeycomb B, Rock, of the series Phenomenon represent the finest of modern-day Italian craftsmanship. - Each mosaic card is individually pressed with a bespoke 100-holes mould, expressly created to achieve a materic and artisanal feeling, then fired through a bespoke, patented, process. - Mutina patented production process and machines (Industrial Patent filed on 02/09/2010 under number MO2010A000247) - The cards are manually assembled accurately by expert hands to build a unique, innovative pattern.
patent	Registered design n° 001912999-0011 - date of registration: 06/09/2011
category	UNI EN 14411 App G (BIA group) GL

RAIN A

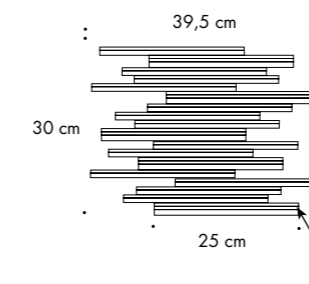

net 25-30 cm
net 9 7/8" 12"

section

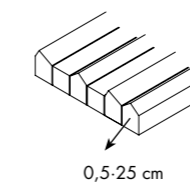

HONEYCOMB B

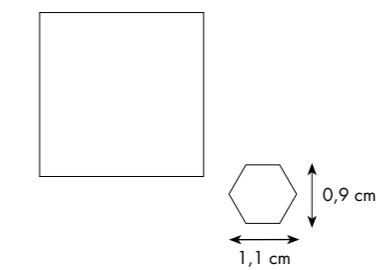

net 30-30 cm
net 12" 12"

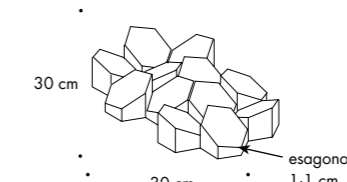

ROCK

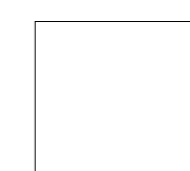

net 29-29 cm
net 11 13/16" 11 13/16"

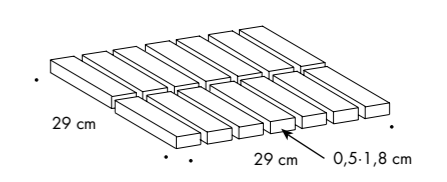

For information about the available grouts, please contact the sales department.

Laying and maintenance tips

use	Walls, indoors.
installation	Lay on perfectly flat, dry walls.
recommended adhesive	NON-RAPID-DRYING adhesive for porcelain stoneware to make it easier to fix the sheets.
recommended joints	Place the sheets with the same joint as within the sheet.
recommended fillers	FINE-GRAIN CEMENT-BASED GROUT: (all mosaics). Grout 0.5 m ² at a time and wash thoroughly with clean water only. Remove all traces of grout carefully before it dries completely. EPOXY GROUT: (PHENOMENON ROCK GLOSSY BIANCO and PHENOMENON ROCK GLOSSY NERO only). Grout 0.5 m ² at a time and wash thoroughly with clean water. Remove all traces of grout carefully before it dries completely. Do not use epoxy grout for ORO and ARGENTO finishes and for version RAIN A and HONEYCOMB B in GLOSSY BIANCO and NERO finishes.
advice for cleaning at the end of the work	CEMENT-BASED GROUT: Grout 0.5 m ² at a time and wash thoroughly with clean water. Remove all traces of grout carefully before it dries completely. EPOXY GROUT: (PHENOMENON ROCK GLOSSY BIANCO and PHENOMENON ROCK GLOSSY NERO only) Alkaline detergent (e.g. FILA CR10 by FILA). FILA CR10: apply pure, wait for 30 minutes then use a green scotch Brite pad. Do not use epoxy grout for ORO and ARGENTO finishes and for version RAIN A and HONEYCOMB B in GLOSSY BIANCO and NERO finishes. Clean with water only.
advice for routine cleaning	We advise using neutral detergent diluted in water. Do not use acid or alkaline products, waxes and/or stains. Where possible, for routine cleaning avoid the use of abrasive sponges (scouring pads, metal sponges).
calibers (real size)	–

Colors

RAIN A GLOSSY



Rain A Bianco Glossy

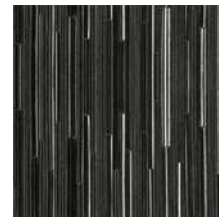

Rain A Nero Glossy



Rain A Oro



Rain A Argento

HONEYCOMB B GLOSSY



Honeycomb B Bianco Glossy

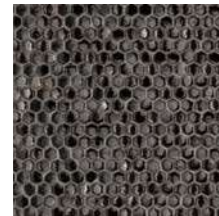

Honeycomb B Nero Glossy

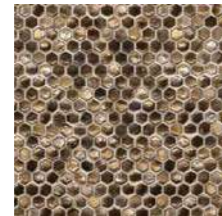

Honeycomb B Oro

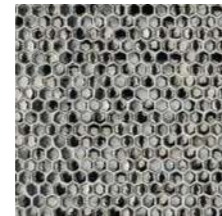

Honeycomb B Argento

ROCK GLOSSY



Rock Bianco Glossy



Rock Nero Glossy



Rock Oro

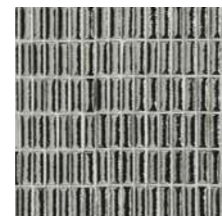

Rock Argento

Technical features

STANDARD	FEATURES	VALUE REQUIRED	PHENOMENON
ISO 10545/3	water absorption	< 0,5%	0,1%
ISO 10545/9	resistance to thermal shock	no visible alteration	resistant
ISO 10545/12	frost resistance	no visible alteration	resistant
ISO 10545/13	resistance to chemical attacks	minimum B	A B glossy finishing
ISO 10545/14	stains resistance	minimum 3	5
VOC Emission			available upon request
Declaration of Contents			available upon request
EPD			available upon request
SDS			available upon request
BPD3			available upon request
HPD			available upon request

Packing

SIZE	PCS-SQM	PCS-BOX	SQM-BOX	BOX-PAL	KG-BOX	KG-PAL	SQM-PAL
rain A net 25-30 cm	13,34	5	0,375	60	4,55	273,00	22,50
rain B net 25-30 cm	13,34	5	0,375	60	4,55	273,00	22,50
rain C net 25-30 cm	13,34	5	0,375	60	4,55	273,00	22,50
honeycomb A net 30-30 cm	11,11	8	0,72	42	7,50	315,00	30,24
honeycomb B net 30-30 cm	11,11	8	0,72	42	8,55	315,00	30,24
rock net 29-29 cm	11,90	11	0,92	42	8,10	340,00	38,64
air net 30-30 cm	11,11	11	0,99	42	10,10	424,00	41,58
wind net 25-25 cm	16,00	8	0,50	60	5,60	336,00	30,00
raccordo esterno honeycomb A+B 9,4-7,6-7,3 cm	86 ml	26	0,30	–	0,05	–	–

Pico

collection	Pico
design	Ronan & Erwan Bouroullec, 2011 – 2015 – 2021
production	Industrial
material	Unglazed homogeneous porcelain stoneware
features	Squared and rectified slabs each one exactly the same as the others
thickness	12 mm
nominal sizes	120-120 cm (47"- 47") 60-120 cm (24"- 47") 60-60 cm (24"- 24")
specification	<ul style="list-style-type: none"> - 4 base colors: Blanc, Gris, Argile, Satin - 2 relief and bas-relief 1,5 mm dotted textures (UP and DOWN) - Mixed color tones clay to achieve a materic and natural feeling - Silk-screen decoration (no digital printing) with perfectly centered color dots - Continua technology pressing process after decoration
complementary pieces	Step, Corner tile, Skirting
awards	Red Dot Design Award 2012, Selected for Adi Design Index 2012
patents	Registered design n° 001912999-0011 – date of registration: 06/09/2011
category	UNI EN 14411 App G (BIA group) UGL



Scan the QR code to download the technical features in other languages

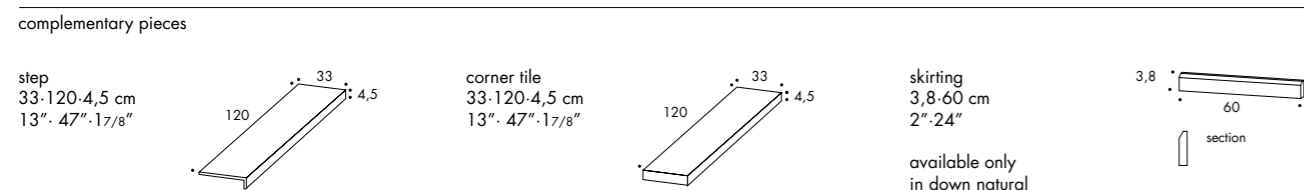
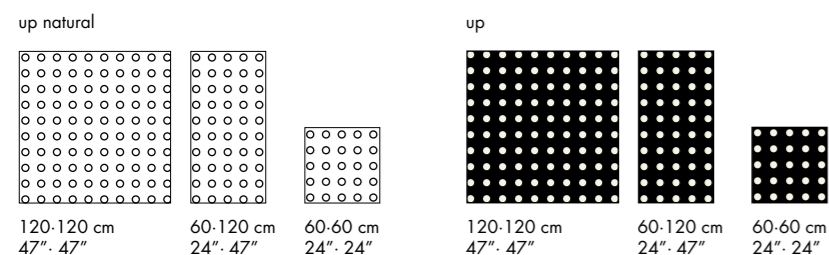
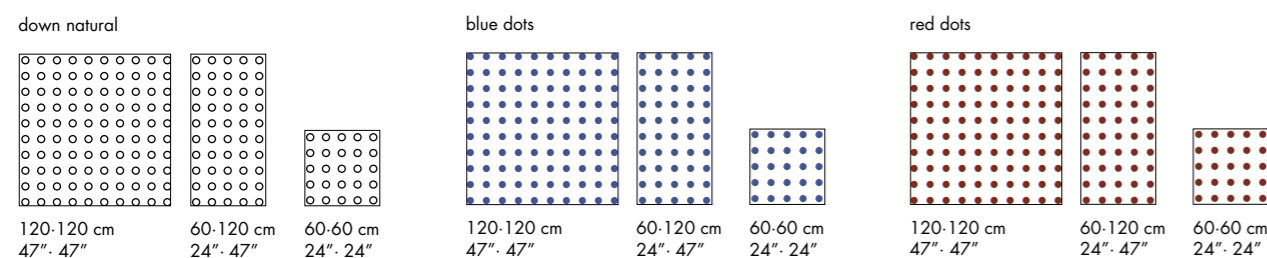

Laying and maintenance tips

use	Floor, wall – indoor, outdoor.
installation	For an even, smooth shading effect when laying, alternate material from several different boxes. The double spreading technique is recommended for the 120x120 size.
recommended adhesive	Adhesive for porcelain stoneware.
recommended joints	2mm joints. Use wedges to fix the caliber differences in work size between tiles.
recommended fillers	Cement-based grout / epoxy grout. Remove all traces of grout carefully before it dries completely.
cleaning at the end of installation	CEMENT-BASED GROUT: Buffered acid (e.g. DETERDEK PRO by FILA, or similar). Wet the floor with water, dilute the product 1:5 with water and pour it on the floor. Wait for 2 or 3 minutes then use a white scotch brite pad and rinse well with clean water. EPOXY GROUT: Alkaline detergent (e.g. FILA CR10 by FILA). FILA CR10: apply pure, wait for 30 minutes then use a green scotch brite pad. SILICONE: Solvent for silicone (e.g. FILA ZERO SIL.). Pour it straight onto the stain, wait for 20 minutes and remove the mark using scotch brite. PAINT: Can usually be removed using water, but if resin-based paints or particular enamels have been used, it is best to ask the manufacturer which solvent is most suitable. RUST: stain remover es. FILA NO RUST. Apply the product onto the stain, leave for 15 minutes, remove the residue and rinse thoroughly.
general cleaning (installed tiles)	You are recommended to use ordinary neutral detergent diluted in water. Avoid using acid or alkaline products, waxes and/or impregnants. During ordinary cleaning it is recommended to use extremely abrasive items (such as scourers and iron or steel sponges) as little as possible. This recommendation must be adhered to rigorously in the case of tiles with a glossy surface finishing as they are more susceptible to the risk of scuffs, scratches and loss of shine, etc. In the event of heavy dirt or particularly textured surfaces, use an alkaline detergent and rinse after washing. For large surfaces, the use of a floor washing machine is recommended. During every-day cleaning procedures, it is necessary to remember that certain types of dirt (dust, sand) increase the abrasive effect of foot-traffic. Therefore we recommend that you avoid bringing in this type of dirt, which comes in from the outside, by placing a door-mat at the entrance.
calibers (real size)	60 cm x 60 cm -> 594 mm x 594 mm 120 cm x 120 cm -> 594 mm x 1190 mm 120 cm x 120 cm -> 1190 mm x 1190 mm

Colors

GRIS

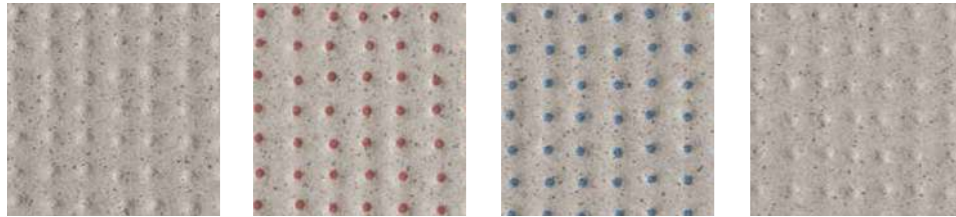

Down Natural Red Dots Blue Dots Up Natural

BLANC

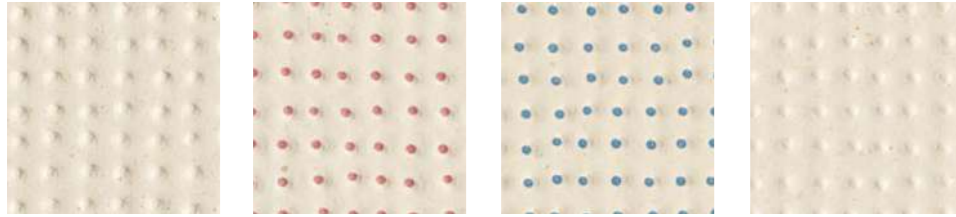

Down Natural Red Dots Blue Dots Up Natural

SATIN



Down Natural Red Dots Blue Dots Up Natural

ARGILE

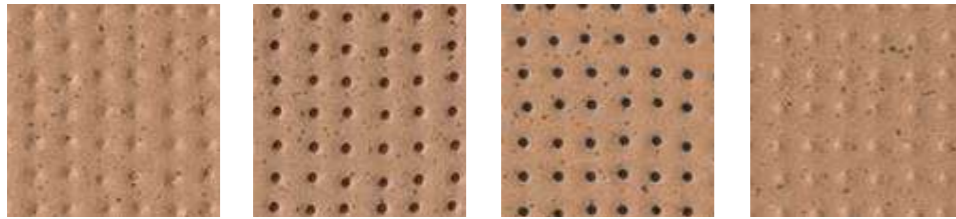

Down Natural Red Dots Blue Dots Up Natural

BLUE

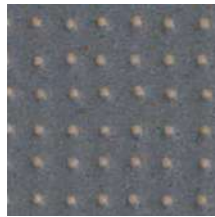

Up Blue

RED

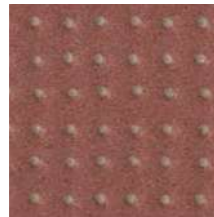

Up Red

For information about the available grouts, please contact the sales department.

Technical features

STANDARD	FEATURES	VALUE REQUIRED	PICO
ISO 10545/2	SIZES length and width thickness straightness of edges wedging flatness	$\pm 0,6\%$ $\pm 5\%$ $\pm 0,5\%$ $\pm 0,6\%$ $\pm 0,5\%$	in conformity with standard
ISO 10545/3	water absorption	< 0,5%	0,06%
ASTM C373		< 0,5%	0,06%
ISO 10545/4	breaking strength	≥ 35 N/mm	61,2 N/mm ²
ISO 10545/6	resistance to deep abrasion	<175 mm ³	in conformity
EN 101	surface hardness (scala mohs)	> 5	8
ISO 10545/9	resistance to thermal shock	no visible alteration	resistant
ASTM C484		no samples must show visible defects	unaffected
ISO 10545/12	frost resistance	no visible alteration	resistant
ASTM C1026		unaffected	unaffected
ISO 10545/13	resistance to chemical attacks	no visible alteration	resistant
ASTM C650			unaffected
ISO 10545/14	stains resistance	minimum 3	5
DIN 51130-04	slip resistance	medium values 6÷10° R9 10÷19° R10 19÷27° R11 27÷35° R12 > 35° R13	UP R11 DOWN R11 SATIN UP R10 SATIN DOWN R9
DIN 51097			UP B DOWN A SATIN UP B SATIN DOWN A
DCOF		> 0,42	UP 0,59 DOWN 0,70 SATIN UP 0,47 SATIN DOWN 0,55
Pendulum BS7976-2			UP 53 dry - 38 wet DOWN 49 dry - 31 wet SATIN UP 58 dry - 29 wet SATIN DOWN 57 dry - 28 wet
LEED CERTIFICATION 4.1			20% recycled material
ENVIROMENTAL MANAGEMENT SYSTEM ISO 14000 E ISO 9001			
 UPEC			available upon request
VOC Emission			available upon request
Declaration of Contents			available upon request
EPD			available upon request
SDS			available upon request
BPD3			available upon request
HPD			available upon request

Packing

SIZE	PCS-SQM	SQM-PCS	PCS-PAL	KG-PCS	KG-PAL	SQM-PAL
120-120 cm	0,69	1,44	36	38,30	1379	51,84

SIZE	PCS-SQM	PCS-BOX	SQM-BOX	BOX-PAL	KG-BOX	KG-PAL	SQM-PAL
60-120 cm	1,38	2	1,44	24	38,65	928,00	34,56
60-60 cm	2,77	3	1,08	32	29,00	928,00	34,56
step 33-120-4,5 cm	–	2	2,40 ml	–	26,00	–	–
corner tile 33-120-4,5 cm	–	1	1,20 ml	–	13,50	–	–
skirting 3,8-60 cm	–	10	6 ml	–	5,00	–	–



Scan the QR code to download the technical features in other languages

Primavera

collection	Primavera
design	Edward Barber & Jay Osgerby, 2018
production	Industrial
material	Unglazed porcelain stoneware
thickness	6 mm
nominal sizes	120-240 cm (47"-94") 120-120 cm (47"-47") 40-120 cm (16"-47") 60-60 cm (24"-24")
specification	– 5 colors – Solid ceramic flakes included in the tiles' surface (no digital printing) randomly applied on the surface and dry-pressed with Continua Plus technology for a non-repetitive graphic pattern – Soft-Shaded base color surface created using patented Soluble-salt-technology (no digital printing) – UGL unglazed technical product that allows its use both for floors and walls, inside and outside and suitable for high traffic areas
awards	German Design Awards 2020 2019 Archiproducts Design Award (Primavera Grigio)
patents	Registered design n° 006336608-0001/0037 – date of registration: 26/03/2019
category	UNI EN 14411 App G (BIA group) UGL



60-60 cm
24"-24"



40-120 cm
16"-47"



120-120 cm
47"-47"



120-240 cm
47"-94"

Laying and maintenance tips

use	Floor, wall – indoor, outdoor, ventilated facade (after applying safety fibre).
installation	Check the flatness with a 2 metre long straight edge, by placing it on the screed in all directions. Maximum permissible tolerance 3 mm. Use specific self-levelling products if the difference is greater.
recommended adhesive	For tiling a floor on substrates such as cement and anhydrite screed (after applying a primer), Class C2S2 cementitious adhesives are normally used for the largest format. On floor heating, even smaller formats must be laid with Class C2S2 cementitious adhesives. On pre-existing or old ceramic tiled floors, it is advisable to use quick-setting adhesives.
recommended joints	2mm joints. Use wedges to fix the caliber differences in work size between tiles.
recommended fillers	Cementitious grout / epoxy grout.
cleaning at the end of installation	CEMENT-BASED GROUT: Buffered acid (e.g. DETERDEK PRO by FILA, or similar). Wet the floor with water, dilute the product 1:5 with water and pour it on the floor. Wait for 2 or 3 minutes then use a white scotch brite pad and rinse well with clean water. EPOXY GROUT: Alkaline detergent (e.g. FILA CR10 by FILA). FILA CR10: apply pure, wait for 30 minutes then use a green scotch brite pad. SILICONE: Solvent for silicone (e.g. FILA ZERO SIL.). Pour it straight onto the stain, wait for 20 minutes and remove the mark using scotch brite. PAINT: Can usually be removed using water, but if resin-based paints or particular enamels have been used, it is best to ask the manufacturer which solvent is most suitable. RUST: stain remover es. FILA NO RUST. Apply the product onto the stain, leave for 15 minutes, remove the residue and rinse thoroughly.
general cleaning (installed tiles)	You are recommended to use ordinary neutral detergent diluted in water. Avoid using acid or alkaline products, waxes and/or impregnants. During ordinary cleaning it is recommended to use extremely abrasive items (such as scourers and iron or steel sponges) as little as possible. This recommendation must be adhered to rigorously in the case of tiles with a glossy surface finishing as they are more susceptible to the risk of scuffs, scratches and loss of shine, etc. In the event of heavy dirt or particularly textured surfaces, use an alkaline detergent and rinse after washing. For large surfaces, the use of a floor washing machine is recommended. During every-day cleaning procedures, it is necessary to remember that certain types of dirt (dust, sand) increase the abrasive effect of foot-traffic. Therefore we recommend that you avoid bringing in this type of dirt, which comes in from the outside, by placing a door-mat at the entrance.
calibers (real size)	120cm x 240cm -> 1190mm x 2382mm 120cm x 120cm -> 1190mm x 1190mm 40cm x 120cm -> 396mm x 1190mm 60cm x 60cm -> 594mm x 594mm

Colors



Bianco

Grigio

Nero

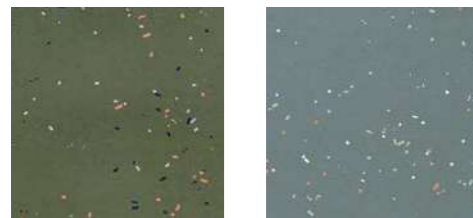

Verde

Blu

For information about the available grouts, please contact the sales department.

Technical features

STANDARD	FEATURES	VALUE REQUIRED	PRIMAVERA
ISO 10545/3	water absorption	< 0,5%	in conformity with standard
ISO 10545/6	resistance to deep abrasion UGL	≤ 175mm ³	in conformity with standard
ISO 10545/9	resistance to thermal shock	no visible alteration	resistant
ISO 10545/12	frost resistance	no visible alteration	resistant
ISO 10545/13	resistance to acids and alkalis (low and high concentration)	declared value	A A
	resistance to household cleaning agents and swimming pool chemicals	minimum class B	A A
ISO 10545/14	stains resistance	minimum 3	5
DIN 51130 - 04	slip resistance	medium values	
		6÷10°	R9
		10÷19°	R10
		19÷27°	R11
		27÷35°	R12
	> 35°	R13	
DIN 51097		–	–
DCOF		> 0,42	0,51
LEED CERTIFICATION 4.1			14% recycled material
ENVIRONMENTAL MANAGEMENT SYSTEM ISO 14000 AND ISO 9001			
Robinson Test			heavy use
VOC Emission			available upon request
Declaration of Contents			available upon request
EPD			available upon request
SDS			available upon request
BPD3			available upon request
HPD			available upon request



Packing

SIZE	PCS-SQM	PCS-BOX	SQM-BOX	BOX-PAL	KG-BOX	KG-PAL	SQM-PAL
120-120 cm	0,69	2	2,88	20	39,50	790	57,60
40-120 cm	2,08	4	1,92	36	26,00	936	69,12
120-240 cm	0,35	1	2,88	22	39,00	858	63,36
60-60 cm	2,77	4	1,44	44	20	880	63,36

Punto

collection	Punto
design	Ronan & Erwan Bouroullec, 2021
production	Industrial
material	Glazed pressed body
thickness	Punto Down 13 mm – Punto Up 15 mm
sizes	Punto Down: 5 pcs 31,5-4-1,3 cm (12''- 1,6''- 0,5'') on net: 21,1-31,5 cm (8''- 12'') Punto Up: 5 pcs 31,5-4-1,5 cm (12''- 1,6''- 0,5'') on net: 21,1-31,5 cm (8''- 12'')
specification	– 2 shapes: up and down – 5 matt colors: white, grey, red, blue, green – 3 glossy colors: blanc, gris, rose – 2 glossy colors with craquelé glaze: vert and brun
use	Wall – indoor
awards	Best of Year 2022
category	Bill UNI EN 14411 GL
patents	Registered design n° 009069826 – 001/0008 – date of registration: 27/06/2022

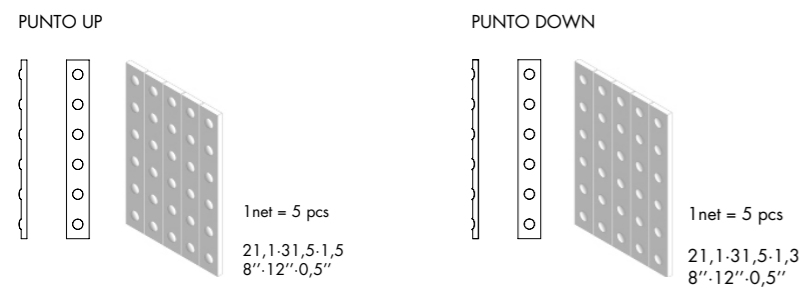

Scan the QR code to download the technical features in other languages

Colors

GLOSSY



Up Blanc



Down Blanc



Up Gris



Down Gris



Up Brun



Down Brun



Up Vert

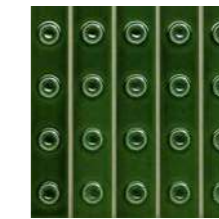

Down Vert



Up Rose



Down Rose

Laying and maintenance tips

use	Wall – indoor
installation	Lay on perfectly flat, dry walls.
recommended adhesive	NON RAPID DRYING adhesive for porcelain stoneware to make it easier to fix the sheets.
recommended joints	Place the sheets with the same joint as within the sheet.
recommended fillers	FINE-GRAIN CEMENT BASE GROUT: Grout 0.5 m2 at a time and wash thoroughly with clean water. Remove all traces of grout carefully before it dries completely. EPOXY GROUT: Grout 0.5 m2 at a time and wash thoroughly with clean water. Remove all traces of grout carefully before it dries completely. Do not use for Punto Vert and Punto Brun.
cleaning at the end of installation	– Punto Vert and Punto Brun: do not use abrasive cleaners / do not use acid or alkaline products. / Craquelé is a type of glazed ceramics characterised by micro-cracks on the surface, deliberately created as a distinctive finish. This particular process makes the material sensitive to acids. For ordinary maintenance, anti-limescale products should be avoided, because they can dull the surface. Please proceed as follows: 1. Treatment pre-grouting with FILA MP90, solvent based stain protector. 2. Grouting with cement-based grout, possibly do not grout in contrast 3. Cleaning at the end of installation with cleaner FILA CLEANER PRO, neutral detergent, dilute the product in a ratio 1:30 4. Final cleaning with FILA MP90 – Punto Matt and Glossy: do not use abrasive cleaners, especially for glossy finishing. FINE-GRAIN CEMENT BASE GROUT: Buffered acid (e.g. Deterdek by FILA, Deltaplus by KERAKOLL, or similar). Wet the floor with water, dilute the product 1:5 with water and pour it on the floor. Wait for 5 minutes then use a white scotch brite pad and rinse well with clean water. EPOXY GROUT: Alkaline detergent (e.g. Fugasocap by KERAKOLL, PS/87 by FILA). Wet the floor with water, dilute the product 1:5 with water and pour it on the floor. Wait for 5 minutes then use a white scotch brite pad and rinse well with clean water. SILICONE: Solvent for silicone (e.g. Remosil). Pour it straight onto the stain, wait for 1-2 minutes and remove the mark using scotch brite. PAINT: Can usually be removed using water, but if resin-based paints or particular enamels have been used, it is best to ask the manufacturer which solvent is most suitable.
general cleaning (installed tiles)	Punto Vert and Punto Brun: do not use abrasive cleaners / do not use acid or alkaline products. For ordinary maintenance, anti-limescale products should be avoided, because they can dull the surface. Punto Matt and Glossy do not use abrasive cleaners, especially for glossy finishing.
calibers (real size)	–

For information about the available grouts, please contact the sales department.

Colors

MATT



Up White



Down White

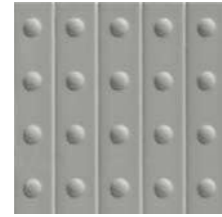

Up Grey

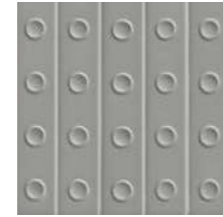

Down Grey

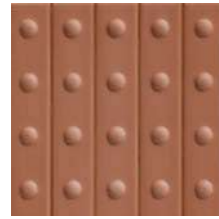

Up Red

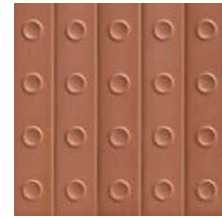

Down Red

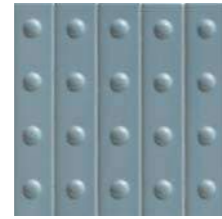

Up Blue



Down Blue



Up Green

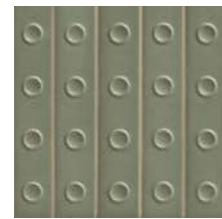

Down Green

For information about the available grouts, please contact the sales department.

Technical features

STANDARD	FEATURES	VALUE REQUIRED	PUNTO
ISO 10545/3	water absorption	x >10%	17,0%
ISO 10545/4	breaking strength	Sp > 7,5 min 600	in conformity
ISO 10545/9	resistance to thermal shock	no visible alteration	unaffected
ISO 10545/11	crazing resistance	no visible alteration	unaffected
ISO 10545/13	resistance to chemical attacks	min B	A – B
ISO 10545/14	stains resistance	class 3	class 5
LEED CERTIFICATION 4.1			64% recycled material
VOC Emission			available upon request
Declaration of Contents			available upon request
SDS			available upon request
BPD3			available upon request
HPD			available upon request

Packing

SIZE	PCS-SQM	PCS-BOX	SQM-BOX	BOX-PAL	KG-BOX	KG-PAL	SQM-PAL
punto down 21,1-31,5-1,3	15	12	0,79	63	15	945	49,77
punto up 21,1-31,5-1,5	15	12	0,79	60	15	900	47,40

Puzzle

collection	Puzzle
design	Barber & Osgerby, 2016
production	Industrial
material	Glazed porcelain stoneware
thickness	14 mm
nominal sizes	25.25 cm (10".10")
specification	<ul style="list-style-type: none"> - 8 color ranges. Each color range is composed of: <ul style="list-style-type: none"> - 1 Set of 6 different graphic patterns using 3 color - 3 plain tiles in the 3 base color of each range - 1 set of 2 symmetrical edge patterns, in 2 of the 3 plain color - 14 mm thickness with grey solid body - 5 surface textures for a hand-painted effect
complementary pieces	Skirting
awards	Edida China 2016, Best of Year 2016, HD Award 2017
patents	Registered design n° 003065440 – date of registration: 12/04/2016
category	UNI EN 14411 App G (BIA group) GL



Scan the QR code to download the technical features in other languages

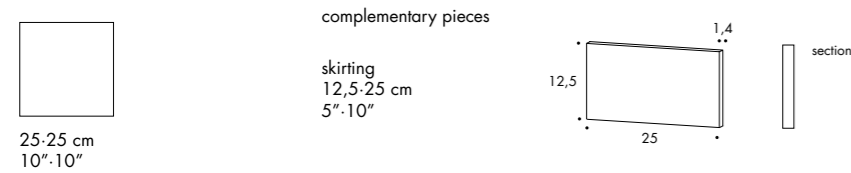

features



Laying and maintenance tips

use	Floor, wall – indoor, outdoor
installation	For an even, smooth shading effect when laying, alternate material from several different boxes.
recommended adhesive	Adhesive for porcelain stoneware.
recommended joints	2mm joints. Use wedges to fix the caliber differences in work size between tiles.
recommended fillers	Cement-based grout / epoxy grout.
cleaning at the end of installation	<p>CEMENT-BASED GROUT: Buffered acid (e.g. DETERDEK PRO by FILA, or similar). Wet the floor with water, dilute the product 1:5 with water and pour it on the floor. Wait for 2 or 3 minutes then use a white scotch brite pad and rinse well with clean water.</p> <p>EPOXY GROUT: Alkaline detergent (e.g. FILA CR10 by FILA). FILA CR10: apply pure, wait for 30 minutes then use a green scotch brite pad.</p> <p>SILICONE: Solvent for silicone (e.g. FILA ZERO SIL.). Pour it straight onto the stain, wait for 20 minutes and remove the mark using scotch brite.</p> <p>PAINT: Can usually be removed using water, but if resin-based paints or particular enamels have been used, it is best to ask the manufacturer which solvent is most suitable.</p> <p>RUST: stain remover es. FILA NO RUST. Apply the product onto the stain, leave for 15 minutes, remove the residue and rinse thoroughly.</p>
general cleaning (installed tiles)	You are recommended to use ordinary neutral detergent diluted in water. Avoid using acid or alkaline products, waxes and/or impregnants. During ordinary cleaning it is recommended to use extremely abrasive items (such as scourers and iron or steel sponges) as little as possible. This recommendation must be adhered to rigorously in the case of tiles with a glossy surface finishing as they are more susceptible to the risk of scuffs, scratches and loss of shine, etc. In the event of heavy dirt or particularly textured surfaces, use an alkaline detergent and rinse after washing. For large surfaces, the use of a floor washing machine is recommended. During every-day cleaning procedures, it is necessary to remember that certain types of dirt (dust, sand) increase the abrasive effect of foot-traffic. Therefore we recommend that you avoid bringing in this type of dirt, which comes in from the outside, by placing a door-mat at the entrance.
calibers (real size)	cal 1 : 251x251 - cal 0 : 249x249 - cal 9 : 247x247 (calibers depend on the production lot, we recommend to ask in advance)

For information about the available grouts, please contact the sales department.

Colors

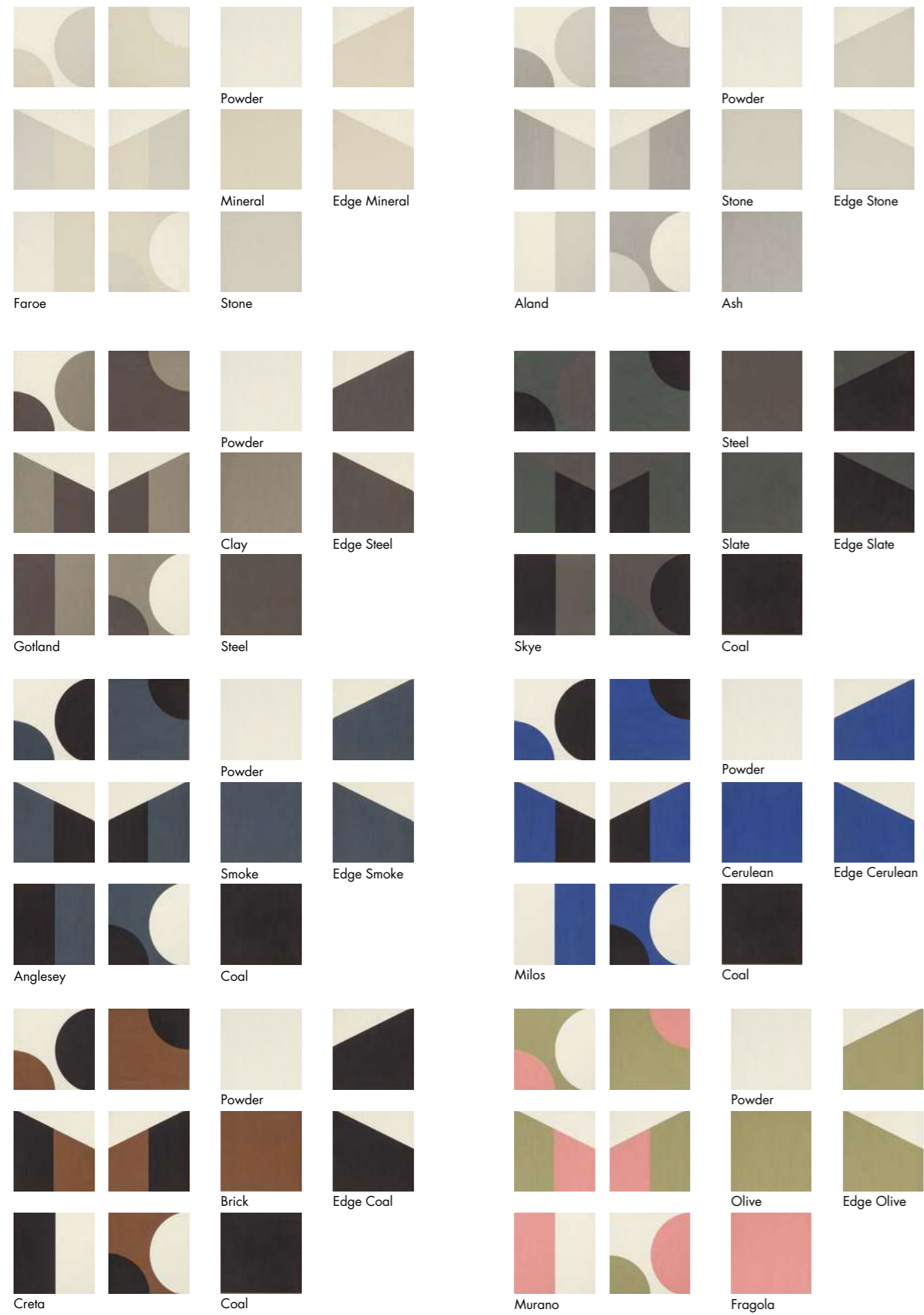

For information about the available grouts, please contact the sales department.

Technical features

STANDARD	FEATURES	VALUE REQUIRED	PUZZLE
ISO 10545/3	water absorption	< 0,5%	0,06%
ASTM C373		< 0,5%	0,06%
ISO 10545/4	breaking strength	Sp ≥ 7,5 min 1300N	resistant
	breaking strenght classification		U4 (heavy weights)
ISO 10545/9	resistance to thermal shock	no visible alteration	resistant
ISO 10545/12	frost resistance	no visible alteration	resistant
ASTM C1026		unaffected	unaffected
ISO 10545/13	resistance to chemical attacks	no visible alteration	resistant
ASTM C650			unaffected
ISO 10545/14	stains resistance	class 3	class 5
DIN 51130-04	slip resistance	medium values 6÷10° R9 10÷19° R10 19÷27° R11 27÷35° R12 > 35° R13	R10
DIN 51097		-	C
DCOF		> 0,42	0,68
Pendulum AS/NSZ 4586-13			46 P4
LEED CERTIFICATION 4.1			20% recycled material
Robinson Test			moderate use
VOC Emission			available upon request
Declaration of Contents			available upon request
EPD			available upon request
SDS			available upon request
BPD3			available upon request
HPD			available upon request

Packing

SIZE	PCS-SQM	PCS-BOX	SQM-BOX	BOX-PAL	KG-BOX	KG-PAL	SQM-PAL
25-25 cm	16	12	0,75	60	23,50	1410	45,00
set of 6 patterns 25-25 cm	16	12	0,75	60	23,50	1410	45,00
edge 25-25 cm	16	12	0,75	60	23,50	1410	45,00
skirting 12,5-25 cm	-	10	2,50 ml	-	9,80	-	-

Rombini

collection	Rombini
design	Ronan & Erwan Bouroullec, 2015, 2021
production	Industrial + Artisanal
material	LOSANGE: double charge porcelain. TRIANGLE: glazed pressed body.
thickness	TRIANGLE EXTRA SMALL: 16 mm TRIANGLE SMALL, TRIANGLE LARGE: 22 mm LOSANGE: 4,7 mm
nominal sizes	TRIANGLE EXTRA SMALL: 8 pcs 31,5-2-1,6 (12"-1"-0,6"), on net 18x31,5 (7"-12") TRIANGLE SMALL: 5 pcs 31,5-3,5-2,2 cm (12"-1"-1"), on net 18,6-31,5 cm (7"-12") TRIANGLE LARGE: 3 pcs 31,5-6-2,2 cm (12"-2"-1"), on net 18,6-31,5 cm (7"-12") LOSANGE: 27,5-25,7 cm (11"-10")
specification	LOSANGE: - 4 base colors Grey, Blue, Green and Red - 4 tone sur tone grouts - 1 base color White With Losange, the shape of the rhombus becomes bigger and turns into a chip of a mosaic. Made of double charge porcelain stoneware, each piece is installed on 27,5x25,7 cm sheets. The chromatic range results to be deep and intense, thanks to the matt surface which gives a natural character to the product. Even in this case the element is available in two versions, through the usage of matching or with contrasting grout, for a stronger vibration. TRIANGLE: - 3 shapes: Extra Small, Small and Large - 5 Matt colors: White, Grey, Red, Green, Blue - 3 Glossy colors: Blanc, Gris, Rose - 2 Glossy colors with craquelé glaze: Vert and Brun With Triangle, the shape of the rhombus is interpreted in its three-dimensional shape, in order to create games of lights and shadow on the surface: the elements, realized in Large, Small and Extra Small versions, seem to arise from the floor and to carry on the wall covering. Triangle is obtain by press in special 3D mold, then glazed and assembled on net. This allow to use Triangle also on concave or convex curved surfaces.
use	LOSANGE: Floor, wall – indoor, outdoor TRIANGLE: Wall – indoor
complementary pieces	TRIANGLE: Terminal Extra Small, Small and Large in all colors and finishing. Listello in all colors and finishing.
awards	Archiproducts Design Award 2016
patents	Registered design n° 002889055-0019/0024 – date of registration: 03/12/2015
category	Losange UNI EN 14411 App G (BIA group) UGL Triangle BIII UNI EN 14411 GL

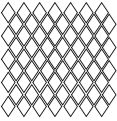
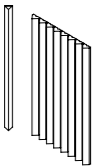
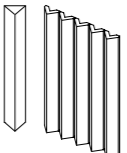
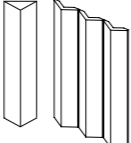

Scan the QR code to download the technical features in other languages

LOSANGE	TRANGLE EXTRA SMALL	TRANGLE SMALL	TRANGLE LARGE
			
27,5-25,7 cm 11"-10"	8 pcs 31,5-2-1,6 12"-1"-0,6" on net 18x31,5 7"-12"	5 pcs 31,5-3,5-2,2 cm 12"-1"-1" on net 18,6-31,5 cm 7"-12"	3 pcs 31,5-6-2,2 cm 12"-2"-1" on net 18,6-31,5 cm 7"-12"

complementary pieces

Terminal
Extra Small/Small/Large

Extra Small:
26,9- H 1,5- 2,8 cm
11"- H 1"-2"
Small:
25,7- H 1,5- 2,8 cm
10"- H 1"-2"
Large:
24,6- H 1,5- 2,8 cm
10"- H 1"-2"

Closing piece available in all colours of the collection.
1 piece of Terminal Small is modular with 7 pieces of Triangle Small. 1 piece of Terminal Large is modular with 4 pieces of Triangle Large. 1 piece of Terminal Extra Small is modular with 12 pieces of Triangle Extra Small.

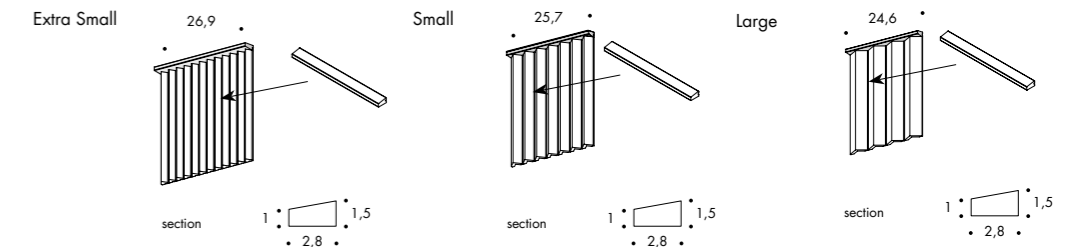

Listello di chiusura

9- 31,5- 0,6 cm
4"- 12"-1"

Listello with a glazed edge to be used in the corner as wall closure or as a connector between Triangle (Small, Extra Small and Large) and Losange. Available in all colours of the collection.

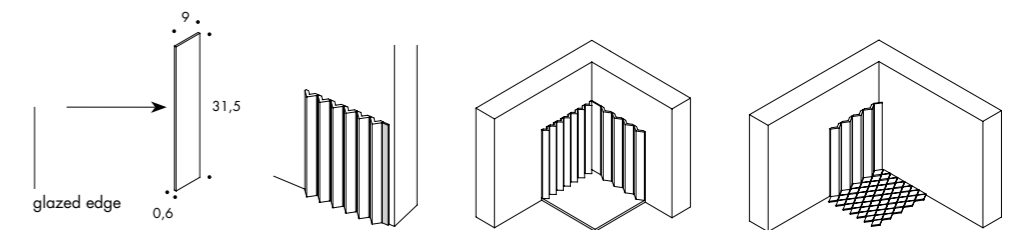

Losange

Laying and maintenance tips

use	Floor, wall – indoor, outdoor.
installation	Lay on perfectly flat, dry walls
recommended adhesive	NON-RAPID-DRYING adhesive for porcelain stoneware to make it easier to fix the sheets.
recommended joints	Place the sheets with the same joint as within the sheet.
recommended fillers	CEMENT-BASED GROUT: wash thoroughly with clean water. Remove all traces of grout carefully before it dries completely. EPOXY GROUT: wash thoroughly with clean water. Remove all traces of grout carefully before it dries completely.
cleaning at the end of installation	CEMENT-BASED GROUT: Buffered acid (e.g. DETERDEK PRO by FILA, or similar). Wet the floor with water, dilute the product 1:5 with water and pour it on the floor. Wait for 2 or 3 minutes then use a white scotch brite pad and rinse well with clean water. EPOXY GROUT: Alkaline detergent (e.g. FILA CR10 by FILA). FILA CR10: apply pure, wait for 30 minutes then use a green scotch brite pad. SILICONE: Solvent for silicone (e.g. FILA ZERO SIL). Pour it straight onto the stain, wait for 20 minutes and remove the mark using scotch brite. PAINT: Can usually be removed using water, but if resin-based paints or particular enamels have been used, it is best to ask the manufacturer which solvent is most suitable. RUST: stain remover es. FILA NO RUST. Apply the product onto the stain, leave for 15 minutes, remove the residue and rinse thoroughly.
general cleaning (installed tiles)	You are recommended to use ordinary neutral detergent diluted in water. Avoid using acid or alkaline products, waxes and/or impregnants. During ordinary cleaning it is recommended to use extremely abrasive items (such as scourers and iron or steel sponges) as little as possible. This recommendation must be adhered to rigorously in the case of tiles with a glossy surface finishing as they are more susceptible to the risk of scuffs, scratches and loss of shine, etc. In the event of heavy dirt or particularly textured surfaces, use an alkaline detergent and rinse after washing. For large surfaces, the use of a floor washing machine is recommended. During every-day cleaning procedures, it is necessary to remember that certain types of dirt (dust, sand) increase the abrasive effect of foot-traffic. Therefore we recommend that you avoid bringing in this type of dirt, which comes in from the outside, by placing a door-mat at the entrance.
calibers (real size)	–

Triangle

Laying and maintenance tips

use	Wall – indoor.
installation	Lay on perfectly flat, dry walls.
recommended adhesive	NON-RAPID-DRYING adhesive for porcelain stoneware to make it easier to fix the sheets.
recommended joints	Place the sheets with the same joint as within the sheet.
recommended fillers	FINE-GRAIN CEMENT BASE GROUT: Grout 0.5 m ² at a time and wash thoroughly with clean water. Remove all traces of grout carefully before it dries completely. EPOXY GROUT: Grout 0.5 m ² at a time and wash thoroughly with clean water. Remove all traces of grout carefully before it dries completely. Do not use for Triangle Vert and Triangle Brun.
cleaning at the end of installation	– Triangle Vert and Triangle Brun: do not use abrasive cleaners / do not use acid or alkaline products. / Craquelé is a type of glazed ceramics characterised by micro-cracks on the surface, deliberately created as a distinctive finish. This particular process makes the material sensitive to acids. For ordinary maintenance, anti-limescale products should be avoided, because they can dull the surface. Please proceed as follows: 1. Treatment pre-grouting with FILA MP90, solvent based stain protector. 2. Grouting with cement-based grout, possibly do not grout in contrast 3. Cleaning at the end of installation with cleaner FILA CLEANER PRO, neutral detergent, dilute the product in a ratio 1:30 4. Final cleaning with FILA MP90 – Triangle Matt and Glossy: do not use abrasive cleaners, especially for glossy finishing. FINE-GRAIN CEMENT BASE GROUT: Buffered acid (e.g. Deterdek by FILA, Deltaplus by KERAKOLL, or similar). Wet the floor with water, dilute the product 1:5 with water and pour it on the floor. Wait for 5 minutes then use a white scotch brite pad and rinse well with clean water. EPOXY GROUT: Alkaline detergent (e.g. Fugasoap by KERAKOLL, PS/87 by FILA). Wet the floor with water, dilute the product 1:5 with water and pour it on the floor. Wait for 5 minutes then use a white scotch brite pad and rinse well with clean water. SILICONE: Solvent for silicone (e.g. Remosil). Pour it straight onto the stain, wait for 1-2 minutes and remove the mark using scotch brite. PAINT: Can usually be removed using water, but if resin-based paints or particular enamels have been used, it is best to ask the manufacturer which solvent is most suitable.
general cleaning (installed tiles)	Triangle Vert and Triangle Brun: do not use abrasive cleaners / do not use acid or alkaline products For ordinary maintenance, anti-limescale products should be avoided, because they can dull the surface. Triangle Matt and Glossy: do not use abrasive cleaners, especially for glossy finishing
calibers (real size)	–

Rombini Triangle – Glossy Colors

TRIANGLE EXTRA SMALL



Blanc

Gris

Brun

Vert

Rose

TRIANGLE SMALL



Blanc

Gris

Brun

Vert

Rose

TRIANGLE LARGE



Blanc

Gris

Brun

Vert

Rose

For information about the available grouts, please contact the sales department.

Rombini Triangle – Matt Colors

TRIANGLE EXTRA SMALL



White Grey Red Green Blue

TRIANGLE SMALL



White Grey Red Green Blue

TRIANGLE LARGE

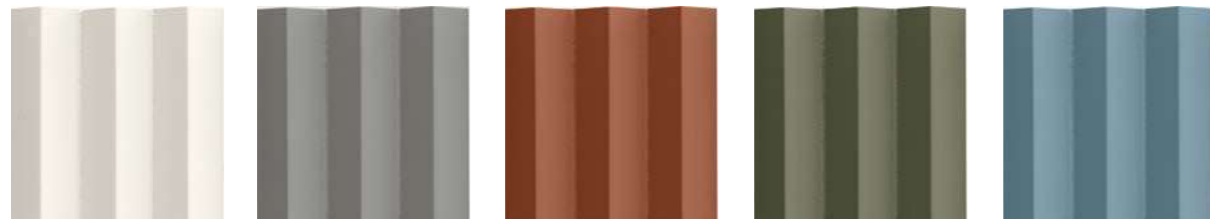

White Grey Red Green Blue

Rombini Losange – Colors



White



Grey



White



Blue

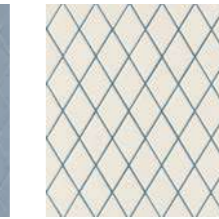

White



Green



White

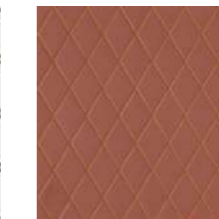

Red



White

For information about the available grouts, please contact the sales department.

For information about the available grouts, please contact the sales department.

Technical features

STANDARD	FEATURES	VALUE REQUIRED	ROMBINI LOSANGE
ISO 10545/3	water absorption	< 0,5%	< 0,5%
ASTM C373		< 0,5%	< 0,5%
ISO 10545/4	breaking strength	Sp<7,5 min 700	in conformity
ISO 10545/6	resistance to deep abrasion	<175 mm3	in conformity
ISO 10545/9	resistance to thermal shock	no visible alteration	resistant
ASTM C484		no samples must show visible defects	unaffected
ISO 10545/12	frost resistance	no visible alteration	resistant
ASTM C1026		unaffected	unaffected
ISO 10545/13	resistance to chemical attacks	no visible alteration	resistant
ASTM C650			unaffected
ISO 10545/14	stains resistance	minimum 3	5
DIN 51130-04	slip resistance	medium values 6÷10° R9 10÷19° R10 19÷27° R11 27÷35° R12 > 35° R13	R10
VOC Emission			available upon request
Declaration of Contents			available upon request
EPD			available upon request
SDS			available upon request
BPD3			available upon request
HPD			available upon request

STANDARD	FEATURES	VALUE REQUIRED	ROMBINI TRIANGLE
ISO 10545/3	water absorption	x >10%	17,0%
ISO 10545/9	thermal shock resistance	no alteration	no alteration
ISO 10545/11	crazing resistance	no alteration	no alteration
ISO 10545/13	acids and alkalis resistance	min B	A – B
ISO 10545/14	stains resistance	class 3	class 5
LEED 4.1		–	64% recycled material
VOC Emission			
Declaration of Contents			
SDS			
BPD3			
HPD			

Packing

SIZE	PCS-SQM	PCS-BOX	SQM-BOX	BOX-PAL	KG-BOX	KG-PAL	SQM-PAL
losange 27,5-25,7 cm	14,00	7	0,50	90	5,00	450	45,00
triangle extra small on net 18-31,5 cm	17,40	11	0,62	63	8,80	554,40	39,06
triangle small on net 18,6-31,5 cm	17	9	0,53	63	11,00	693	33,40
triangle large on net 18,6-31,5 cm	17	9	0,53	63	10,00	630	33,40
terminal extra small	–	10	2,69 ml		3,25		
terminal small	–	10	2,57 ml	–	3,25	–	–
terminal large	–	10	2,46 ml	–	3,25	–	–
listello 8-31,5-0,6 cm	–	–	–	–	–	–	–

Tape

collection	Tape
design	Raw Edges, 2017
production	Industrial
material	Glazed porcelain stoneware
thickness	10 mm
nominal sizes	20,5-20,5 cm (8"-8")
specification	<ul style="list-style-type: none"> - 2 base colors: White and Black - 8 graphic patterns (full pattern) - 8 graphic "half patterns" to create connections and a soft blend on one pattern with the other - 5 combinations of base+colored patterns: 1 on Black base and 4 on White base - Though the tile is NON RECTIFIED the patterns are perfectly centered to obtain a continuous and homogeneous surface - 5 different glazing surface textures random mixed
patents	Registered design n° 004427748-0001/0027 – date of registration: 31/10/2017
category	UNI EN 14411 App G (BIA group) GL



20,5-20,5 cm
8"-8"

Laying and maintenance tips

use	Floor, wall – indoor, outdoor.
installation	For an even, smooth shading effect when laying, alternate material from several different boxes.
recommended adhesive	Adhesive for porcelain stoneware.
recommended joints	2mm joints. Use wedges to fix the caliber differences in work size between tiles.
recommended fillers	Cement-based grout / epoxy grout.
cleaning at the end of installation	<p>CEMENT-BASED GROUT: Buffered acid (e.g. DETERDEK PRO by FILA, or similar). Wet the floor with water, dilute the product 1:5 with water and pour it on the floor. Wait for 2 or 3 minutes then use a white scotch brite pad and rinse well with clean water.</p> <p>EPOXY GROUT: Alkaline detergent (e.g. FILA CR10 by FILA). FILA CR10: apply pure, wait for 30 minutes then use a green scotch brite pad.</p> <p>SILICONE: Solvent for silicone (e.g. FILA ZERO SIL). Pour it straight onto the stain, wait for 20 minutes and remove the mark using scotch brite.</p> <p>PAINT: Can usually be removed using water, but if resin-based paints or particular enamels have been used, it is best to ask the manufacturer which solvent is most suitable.</p> <p>RUST: stain remover es. FILA NO RUST. Apply the product onto the stain, leave for 15 minutes, remove the residue and rinse thoroughly.</p>
general cleaning (installed tiles)	You are recommended to use ordinary neutral detergent diluted in water. Avoid using acid or alkaline products, waxes and/or impregnants. During ordinary cleaning it is recommended to use extremely abrasive items (such as scourers and iron or steel sponges) as little as possible. This recommendation must be adhered to rigorously in the case of tiles with a glossy surface finishing as they are more susceptible to the risk of scuffs, scratches and loss of shine, etc. In the event of heavy dirt or particularly textured surfaces, use an alkaline detergent and rinse after washing. For large surfaces, the use of a floor washing machine is recommended. During every-day cleaning procedures, it is necessary to remember that certain types of dirt (dust, sand) increase the abrasive effect of foot-traffic. Therefore we recommend that you avoid bringing in this type of dirt, which comes in from the outside, by placing a door-mat at the entrance.
calibers (real size)	20,5x20,5: cal 1: from 203,6x203,6 to 205x205 - cal 0: from 202,1x202,1 to 203,5x203,5 (calibers depend on the production lot, we recommend to ask in advance)



Scan the QR code to download the technical features in other languages

Colors



Base Black



Mesh Half Black

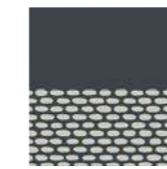

Cobble Half Black



Grainy Half Black

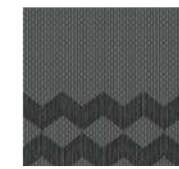

Zigzag Half Black

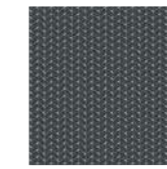

Mesh Black



Cobble Black



Grainy Black



Zigzag Black



Base White



Mesh Half White



Cobble Half White



Grainy Half White

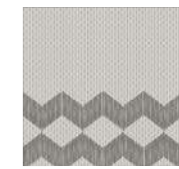

Zigzag Half White



Mesh White



Cobble White

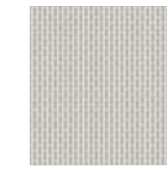

Grainy White

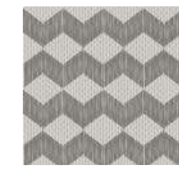

Zigzag White



Base White



Mesh Half Brown

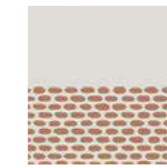

Cobble Half Brown

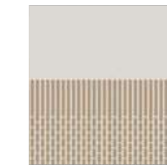

Grainy Half Brown



Zigzag Half Brown

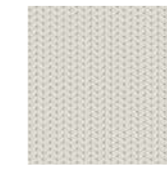

Mesh Brown



Cobble Brown



Grainy Brown



Zigzag Brown

For information about the available grouts, please contact the sales department.

Colors



Base White



Mesh Half Green

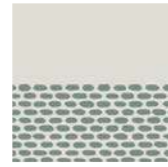

Cobble Half Green



Grainy Half Green



Zigzag Half Green

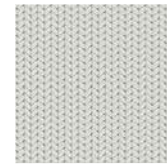

Mesh Green

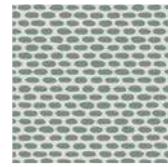

Cobble Green

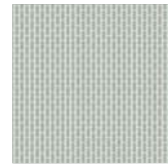

Grainy Green



Zigzag Green



Base White

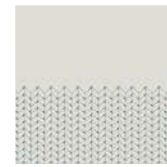

Mesh Half Blue

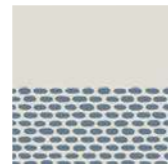

Cobble Half Blue

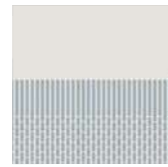

Grainy Half Blue



Zigzag Half Blue

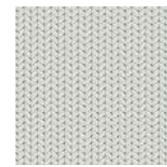

Mesh Blue

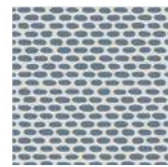

Cobble Blue

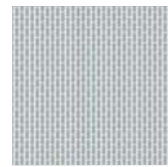

Grainy Blue



Zigzag Blue

Technical features

STANDARD	FEATURES	VALUE REQUIRED	TAPE
ISO 10545/3	water absorption	< 0,5%	0,06%
ISO 10545/4	breaking strenght	Sp ≥ 7,5 min 1300 N	resistant
ISO 10545/9	resistance to thermal shock	no visible alteration	resistant
ISO 10545/12	frost resistance	no visible alteration	resistant
ISO 10545/13	resistance to chemical attacks	no visible alteration	resistant
ISO 10545/14	stains resistance	minimum 3	5
DIN 51130-04	slip resistance	medium values 6÷10° R9 10÷19° R10 19÷27° R11 27÷35° R12 > 35° R13	R10
DIN 51097		-	-
DCOF		> 0,42	0,69
Pendulum AS/NSZ 4586-13			27 P2
LEED CERTIFICATION 4.1			20% recycled material
Robinson Test			heavy use (zig zag half white)
VOC Emission			available upon request
Declaration of Contents			available upon request
EPD			available upon request
SDS			available upon request
BPD3			available upon request
HPD			available upon request



Packing

SIZE	PCS-SQM	PCS-BOX	SQM-BOX	BOX-PAL	KG-BOX	KG-PAL	SQM-PAL
20,5-20,5 cm	23,88	16	0,67	96	14,20	1363,20	64,32

For information about the available grouts, please contact the sales department.

Teknotessere

collection	Teknotessere
design	Mutina Team, 2009
production	Artisanal
material	Homogeneous porcelain stoneware tesserae obtained by pressing and fixed on net
thickness	7 mm
nominal sizes	1.1 cm (3/8"-3/8") net 30.30 cm (12"-12")
specification	The collection is: – 5 colors Each element is pressed individually in special molds with more than one hundred element hole. These tiles comply with the UGL Class Bla standard, suitable both for the residential market and for large-scale projects.
category	UNI EN 14411 App G (BIA group) UGL

□
1.1 cm
3/8"-3/8"

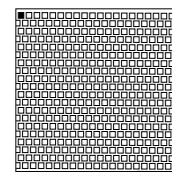

on net 30.30 cm
12"-12"



Scan the QR code to
download the technical
features in other languages

Colors

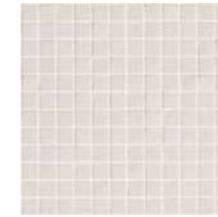

Bianco

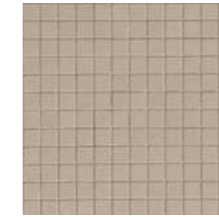

Cemento

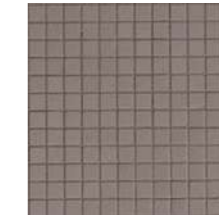

Cenere



Nero

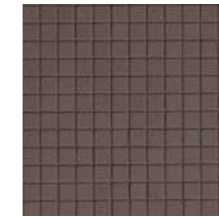

Fango

Laying and maintenance tips

use	Floor, wall – indoor, outdoor.
installation	Lay on perfectly flat, dry walls.
recommended adhesive	NON-RAPID-DRYING adhesive for porcelain stoneware to make it easier to fix the sheets.
recommended joints	Place the sheets with the same joint as within the sheet.
recommended fillers	Cement-based grout / epoxy grout. Remove all traces of grout carefully before it dries completely.
cleaning at the end of installation	CEMENT-BASED GROUT: Buffered acid (e.g. DETERDEK PRO by FILA, or similar). Wet the floor with water, dilute the product 1:5 with water and pour it on the floor. Wait for 2 or 3 minutes then use a white scotch brite pad and rinse well with clean water. EPOXY GROUT: Alkaline detergent (e.g. FILA CR10 by FILA). FILA CR10: apply pure, wait for 30 minutes then use a green scotch brite pad. SILICONE: Solvent for silicone (e.g. FILA ZERO SIL). Pour it straight onto the stain, wait for 20 minutes and remove the mark using scotch brite. PAINT: Can usually be removed using water, but if resin-based paints or particular enamels have been used, it is best to ask the manufacturer which solvent is most suitable. RUST: stain remover es. FILA NO RUST. Apply the product onto the stain, leave for 15 minutes, remove the residue and rinse thoroughly.
general cleaning (installed tiles)	You are recommended to use ordinary neutral detergent diluted in water. Avoid using acid or alkaline products, waxes and/or impregnants. During ordinary cleaning it is recommended to use extremely abrasive items (such as scourers and iron or steel sponges) as little as possible. This recommendation must be adhered to rigorously in the case of tiles with a glossy surface finishing as they are more susceptible to the risk of scuffs, scratches and loss of shine, etc. In the event of heavy dirt or particularly textured surfaces, use an alkaline detergent and rinse after washing. For large surfaces, the use of a floor washing machine is recommended. During every-day cleaning procedures, it is necessary to remember that certain types of dirt (dust, sand) increase the abrasive effect of foot-traffic. Therefore we recommend that you avoid bringing in this type of dirt, which comes in from the outside, by placing a door-mat at the entrance.
calibers (real size)	–

For information about the available grouts, please contact the sales department.

Technical features

STANDARD	FEATURES	VALUE REQUIRED	TEKNOTESSERE
ISO 10545/3	water absorption	< 0,5%	0,07%
ISO 10545/4	breaking strength	Sp < 7,5 min 700	in conformity
ISO 10545/6	resistance to deep abrasion	< 175 mm ³	in conformity
ISO 10545/9	thermal shock resistance	no alteration	no alteration
ISO 10545/12	frost resistance	no alteration	no alteration
ISO 10545/13	acids and alkalis resistance	min B	A
ISO 10545/14	stains resistance	class 3	class 5
DIN 51130-04	slip resistance	medium values 6±10° R9 10±19° R10 19±27° R11 27±35° R12 > 35° R13	R11
DIN 51097		–	–
DCOF			
VOC Emission			available upon request
Declaration of Contents			available upon request
EPD			available upon request
SDS			available upon request
BPD3			available upon request
HPD			available upon request

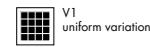

Packing

SIZE	PCS-SQM	PCS-BOX	SQM-BOX	BOX-PAL	KG-BOX	KG-PAL	SQM-PAL
30-30 cm	11,11	11	0,99	36	12,60	454,00	35,64



Scan the QR code to download the technical features in other languages

Tex

collection	Tex
design	Raw Edges, 2012
production	Industrial
material	Glazed porcelain stoneware
thickness	10 mm
nominal sizes	11,5-20 cm (4" - 8") runner 35-40,4 cm (13 25/32" - 15 29/32")
specification	<ul style="list-style-type: none"> – Rhombus shaped tile 11,5 x 20 cm, thickness 10mm, available in 8 colours. – 8 different colors on a matt surface, each of which contains a group of three shades and 5 relief textures inspired by textile design, re-creating the feel of the different tones of the yarn. – The three shades and five textures will be placed randomly in the packages; by this, when installing Tex, arbitrary arrangements could be achieved. On the other hand, in addition to the single tiles installation, premade patterns named "Runner", are available on a mesh similarly to mosaics settings.
complementary pieces	Skirting
awards	Interior Innovation Award 2014
patents	Registered design n° 002193797-0001/0014 - date of registration: 28/02/2013
category	UNI EN 14411 App G (BIA group) GL

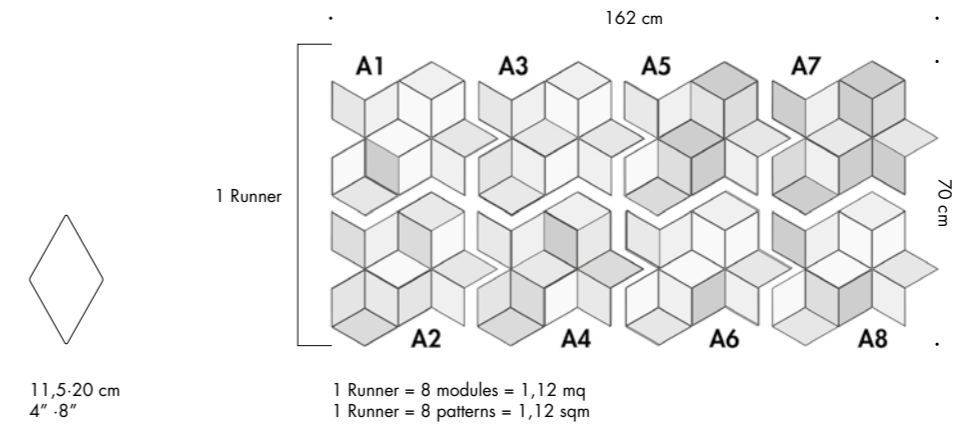

complementary pieces

skirting
10,5-20 cm
4 1/8" - 8"

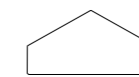

Laying and maintenance tips

use	Floor, wall – indoor, outdoor.
installation	The material is deliberately shaded. Take the material from several boxes and mix carefully.
recommended adhesive	Adhesive for porcelain stoneware.
recommended joints	2mm joints. Use wedges to fix the caliber differences in work size between tiles.
recommended fillers	Cement-based grout / epoxy grout.
cleaning at the end of installation	CEMENT-BASED GROUT: Buffered acid (e.g. DETERDEK PRO by FILA, or similar). Wet the floor with water, dilute the product 1:5 with water and pour it on the floor. Wait for 2 or 3 minutes then use a white scotch brite pad and rinse well with clean water. EPOXY GROUT: Alkaline detergent (e.g. FILA CR10 by FILA). FILA CR10: apply pure, wait for 30 minutes then use a green scotch brite pad. SILICONE: Solvent for silicone (e.g. FILA ZERO SIL). Pour it straight onto the stain, wait for 20 minutes and remove the mark using scotch brite. PAINT: Can usually be removed using water, but if resin-based paints or particular enamels have been used, it is best to ask the manufacturer which solvent is most suitable. RUST: stain remover es. FILA NO RUST. Apply the product onto the stain, leave for 15 minutes, remove the residue and rinse thoroughly.
general cleaning (installed tiles)	You are recommended to use ordinary neutral detergent diluted in water. Avoid using acid or alkaline products, waxes and/or impregnants. During ordinary cleaning it is recommended to use extremely abrasive items (such as scourers and iron or steel sponges) as little as possible. This recommendation must be adhered to rigorously in the case of tiles with a glossy surface finishing as they are more susceptible to the risk of scuffs, scratches and loss of shine, etc. In the event of heavy dirt or particularly textured surfaces, use an alkaline detergent and rinse after washing. For large surfaces, the use of a floor washing machine is recommended. During every-day cleaning procedures, it is necessary to remember that certain types of dirt (dust, sand) increase the abrasive effect of foot-traffic. Therefore we recommend that you avoid bringing in this type of dirt, which comes in from the outside, by placing a door-mat at the entrance.
calibers (real size)	1 mm tolerance

Colors

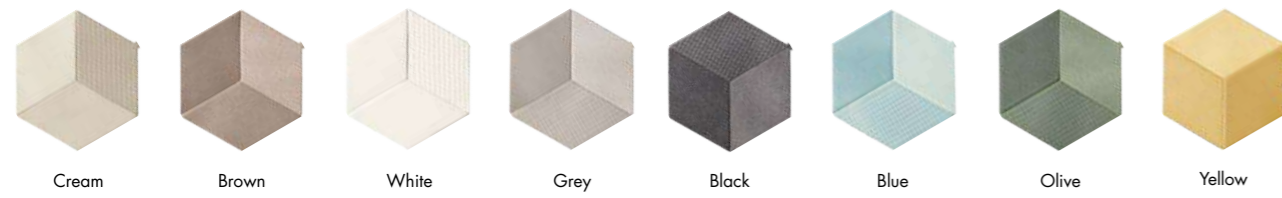

Runner

runner	the Runner is an element composed by 12 rhombus of different colours already set on mesh, so to make the realization of several decors easier
patterns	each Runner is composed by 8 different patterns, not singularly sold and already included in one single package, which enable the realization of many combinations 1 Runner = 8 patterns = 1,12 sqm
10 runner	there are 10 Runners, each of which combined to every colour of the collection. For the white one there are 3 of them
colors	10 Runners, each of which is composed by 8 different patterns, matching with the colours of the collection

Runner 1 White
(white + yellow & cream)

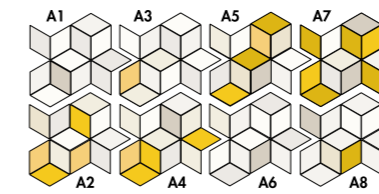

Runner 2 White
(white + olive & cream)

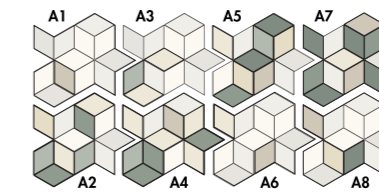

Runner 3 White
(white + blue & cream)

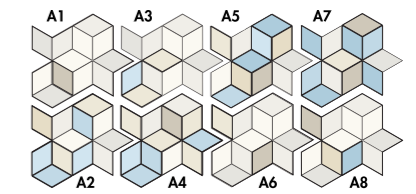

Runner 4 Cream
(cream + brown & white)

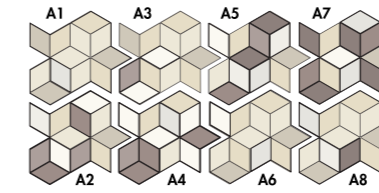

Runner 5 Brown
(brown + cream & white)

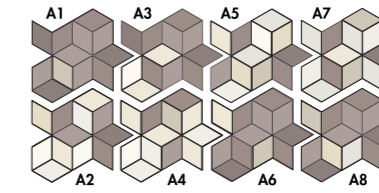

Runner 6 Grey
(grey + cream & white)

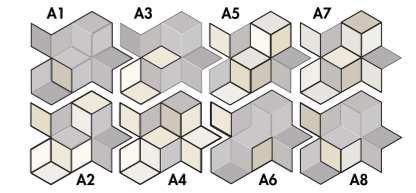

Runner 7 Black
(black + grey & white)

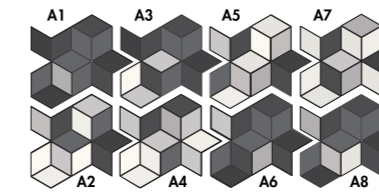

Runner 8 Olive
(olive + cream & white)

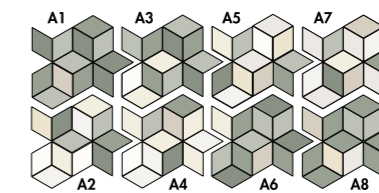

Runner 9 Blue
(blue + cream & white)

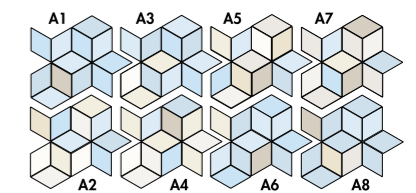

Runner 10 Yellow
(yellow + cream & white)

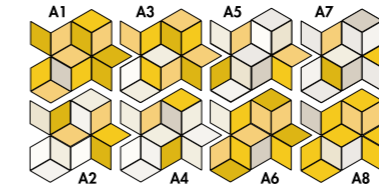

For information about the available grouts, please contact the sales department.

Technical features

STANDARD	FEATURES	VALUE REQUIRED	TEX
ISO 10545/3	water absorption	< 0,5%	0,04%
ASTM C373		< 0,5%	0,04%
ISO 10545/4	breaking strength	Sp> 7,5 min 1300	resistant
EN 101	surface hardness (scala mohs)	> 5	6
ISO 10545/9	resistance to thermal shock	no visible alteration	resistant
ASTM C484		no samples must show visible defects	unaffected
ISO 10545/12	frost resistance	no alteration	no alteration
ISO 10545/13	resistance to chemical attacks	no visible alteration	resistant
ASTM C650			unaffected
ISO 10545/14	stains resistance	minimum 3	5
DIN 51130-04	slip resistance	medium values 6±10° R9 10±19° R10 19±27° R11 27±35° R12 > 35° R13	R10
DIN 51097		–	C
DCOF		> 0,42	0,58
Pendulum BS (slip resistance)		–	45 dry - 36 wet
Pendulum AS/NZS 4586-13		–	39 P3
BCRA (anti-slip)		>0,40	dry: 0,53 wet: 0,49
LEED CERTIFICATION 4.1			24% recycled material
Robinson Test		–	extra heavy and high-impact use
VOC Emission			available upon request
Declaration of Contents			available upon request
SDS			available upon request
BPD3			available upon request
HPD			available upon request



Packing

SIZE	PCS-SQM	PCS-BOX	SQM-BOX	BOX-PAL	KG-BOX	KG-PAL	SQM-PAL
11,5-20 cm	86,96	44	0,51	104	11,56	1202	53,04
runner 35-40,4 cm	0,91 set	1set (8pcs)	1,12	36	22,55	812	40,32
skirting 10,5-20 cm	–	10	2,00 ml	–	3,25	–	–



Scan the QR code to download the technical features in other languages

Tierras

collection	Tierras
design	Patricia Urquiola, 2014
production	Industrial
material	Unglazed porcelain stoneware
features	Squared and rectified slabs each one exactly the same as the others
thickness	12 mm
nominal sizes	120-120 cm (47"-47") 60-60 cm (24"-24") 20-30 cm (8"-12") frame 20-30 cm (8"-12") triomix 120-120 cm (47"-47")
specification	<ul style="list-style-type: none"> – 4 base colors: Blush, Sand, Rust, Brick – Different sizes, all rectified and modular – Triomix: big square size composed by 5 shapes in the same color or in 3 different colors. Each set in composed by 3 patterns not singularly sold – Frame: the decorated base color, in geometrical pattern, is characterized by regular lines in bright and high thickness color. Useful for floor and wall <p>Different kind of terracotta and of clays, chromatically matching with each other, combine and mix, enriching and softening the black base of recycled ceramics on which they deposit, making it timidly emerge on the surface. Tierras is industrial tradition with continua technology. Tierras is realized in homogeneous porcelain stoneware, produced with the innovative continua technology: a modern productive system based on the dry processing of the ceramic powders. From an environmental point of view, this system represents an improvement, having a very limited water waste during production. The base of the field tile, which constitutes the first layer of the slab together with the different productive scraps, has being conceived in one single black color. The "top" layer, the one constituted by the colored powders, a different one for every color of the range, sediments on the first two layers, defining the surface's identity. The result is a very solid substance, characterized by a palette of very intense, deep, earthy and natural colors, saturated by the black base.</p>
complementary pieces	Step, Corner tile, Skirting
category	UNI EN 14411 App G (BIA group) UGL

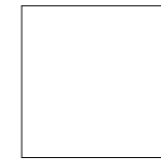

120-120 cm
47"-47"

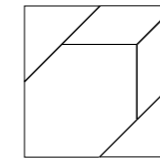

Triomix
120-120 cm
47"-47"



60-60 cm
24"-24"



20-30 cm
8"-12"

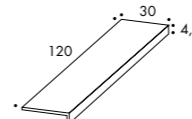
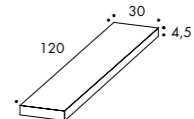
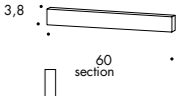

Frame
20-30 cm
8"-12"

complementary pieces	<div style="display: flex; justify-content: space-around; align-items: flex-start;"> <div style="text-align: center;"> <p>step 30-120-4,5 cm 12"-47"-1 7/8"</p>  </div> <div style="text-align: center;"> <p>corner tile 30-120-4,5 cm 12"-47"-1 7/8"</p>  </div> <div style="text-align: center;"> <p>skirting 3,8-60 cm 2"-24"</p>  </div> </div>
----------------------	--

Laying and maintenance tips

use	Floor, wall – indoor, outdoor.
installation	For an even, smooth shading effect when laying, alternate material from several different boxes. The double spreading technique is recommended for the 120x120 size.
recommended adhesive	Adhesive for porcelain stoneware.
recommended joints	2mm joints. Use wedges to fix the caliber differences in work size between tiles.
recommended fillers	Cement-based grout / epoxy grout. Remove all traces of grout carefully before it dries completely.
cleaning at the end of installation	CEMENT-BASED GROUT: Buffered acid (e.g. DETERDEK PRO by FILA, or similar). Wet the floor with water, dilute the product 1:5 with water and pour it on the floor. Wait for 2 or 3 minutes then use a white scotch brite pad and rinse well with clean water. EPOXY GROUT: Alkaline detergent (e.g. FILA CR10 by FILA). FILA CR10: apply pure, wait for 30 minutes then use a green scotch brite pad. SILICONE: Solvent for silicone (e.g. FILA ZERO SIL.). Pour it straight onto the stain, wait for 20 minutes and remove the mark using scotch brite. PAINT: Can usually be removed using water, but if resin-based paints or particular enamels have been used, it is best to ask the manufacturer which solvent is most suitable. RUST: stain remover es. FILA NO RUST. Apply the product onto the stain, leave for 15 minutes, remove the residue and rinse thoroughly.
general cleaning (installed tiles)	You are recommended to use ordinary neutral detergent diluted in water. Avoid using acid or alkaline products, waxes and/or impregnants. During ordinary cleaning it is recommended to use extremely abrasive items (such as scourers and iron or steel sponges) as little as possible. This recommendation must be adhered to rigorously in the case of tiles with a glossy surface finishing as they are more susceptible to the risk of scuffs, scratches and loss of shine, etc. In the event of heavy dirt or particularly textured surfaces, use an alkaline detergent and rinse after washing. For large surfaces, the use of a floor washing machine is recommended. During every-day cleaning procedures, it is necessary to remember that certain types of dirt (dust, sand) increase the abrasive effect of foot-traffic. Therefore we recommend that you avoid bringing in this type of dirt, which comes in from the outside, by placing a door-mat at the entrance.
calibers (real size)	TIERRAS 60cm x 60m -> 594mm x 594mm TIERRAS 120cm x 120cm -> 1190mm x 1190mm TIERRAS 20cm x 30cm -> 196,7mm x 296mm TIERRAS TRIOMIX 120cm x 120cm -> 1190mm x 1190mm

Colors



Blush

Sand

Rust

Brick

FRAME

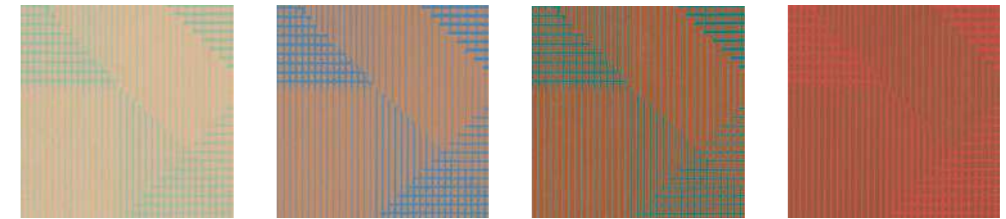

Blush

Sand

Rust

Brick

TRIOMIX



Triomix 1 (sand, rust, brick)

Triomix 2 blush/sand/brick



Triomix 3 (ash, humus, rust)

Triomix 4 (blush, sand, ash)

Each set is composed by 3 patterns not singularly sold.

For information about the available grouts, please contact the sales department.

Technical features

STANDARD	FEATURES	VALUE REQUIRED	TIERRAS
ISO 10545/2	SIZES		
	length and width thickness straightness of edges wedging flatness	± 0,6% ± 5% ± 0,5% ± 0,6% ± 0,5%	in conformity with standard
ISO 10545/3	water absorption	< 0,5%	0,06%
ASTM C373		< 0,5%	0,06%
EN 101	surface hardness (scala mohs)	> 5	8
ISO 10545/6	resistance to deep abrasion	<175 mm3	in conformity
ISO 10545/9	resistance to thermal shock	no visible alteration	resistant
ASTM C484		no samples must show visible defects	unaffected
ISO 10545/12	frost resistance	no visible alteration	resistant
ASTM C1026		unaffected	unaffected
ISO 10545/13	resistance to chemical attacks	no visible alteration	resistant
ASTM C650			unaffected
ISO 10545/14	stains resistance	minimum 3	5
DIN 51130-04	slip resistance	medium values 6÷10° R9 10÷19° R10 19÷27° R11 27÷35° R12 > 35° R13	R10
DIN 51097		–	–
DCOF		> 0,42	0,63
Pendulum AS/NZS 4586-13			37 X
Pendulum BS 7976-2			50 dry 45 wet
Pendulum BS 7976-2			54 dry (item FRAME) 55 wet (item FRAME)
LEED CERTIFICATION 4.1			20% recycled material
ENVIRONMENTAL MANAGEMENT SYSTEM ISO 14000 AND ISO 9001			
VOC Emission			available upon request
Declaration of Contents			available upon request
EPD			available upon request
SDS			available upon request
BPD3			available upon request
HPD			available upon request

Packing

SIZE	PCS-SQM	SQM-PCS	PCS-PAL	KG-PCS	KG-PAL	SQM-PAL
120-120 cm	0,69	1,44	36	38,30	1379,00	51,84

SIZE	SET-SQM	PCS-BOX	SQM-SET	SET-PAL	KG-SET	KG-PAL	SQM-PAL
triomix 120-120 cm	0,23	1 set = 3modules 4,32		6	120,15	721,00	25,92

SIZE	PCS-SQM	PCS-BOX	SQM-BOX	BOX-PAL	KG-BOX	KG-PAL	SQM-PAL
60-60 cm	2,77	3	1,08	32	29,00	928,00	34,56
20-30 cm	16,67	8	0,48	64	13,05	835,00	30,72
step 30-120-4,5 cm	–	2	2,40 ml	–	26,00	–	–
corner tile 30-120-4,5 cm	–	1	1,20 ml	–	13,00	–	–
skirting 3,8-60 cm	–	10	6 ml	–	5,00	–	–
frame 20-30 cm	16,67	8	0,48	51	13,05	666,00	24,48

3D ELEMENTS



Scan the QR code to download the technical features in other languages

Bloc

The data, information and indications contained in this technical data sheet and in further documents relating to the Bloc by Ronan & Erwan Bouroullec product are the exclusive property by Ceramiche MUTINA S.p.a. This Technical Data Sheet provides the buyer with information relating to the use of the product useful for its correct installation and evaluation and prevention of risks arising from the normal use of the same.

collection	Bloc
design	Ronan & Erwan Bouroullec, 2021
production	Artisanal
material	Extruded terracotta, glazed extruded terracotta
nominal sizes	13-13-10 cm [5"-5"-4"]
specification	<ul style="list-style-type: none"> - artisanal extruded partition elements, 10 cm thick - 3 finishing: natural, matt, glossy - 5 colours: Natural (natural finishing), Pearl, Grey, Red, Blue (glossy glaze finishing and matt painted finishing). <p>This product is suitable for both residential and commercial areas, to be installed in walls with height of 4mt. These elements must in any case comply with the technical standards of construction regulation, applicable in the country where they are installed. For the Italian national territory, in particular, they should comply with standard NTC 2018 DECRETO MIN 27/01. For aesthetic outcome it is possible to install BLOC using our wooden profile. The profile is painted and suitable for outdoor use. A top profile with removable sides is provided for ceiling fixing. As complementary pieces Mutina provide the Mutina adhesive, EC 1 plus for VOC emissions. For installation process see the installation video available on www.mutina.it.</p> <p>Bloc Natural is suitable for indoor and outdoor areas complying with UNI EN 772-22 marked "F1- moderate exposure". Bloc Matt and Glossy finishing are suitable for indoor only.</p>
category	UNI 11128/2004

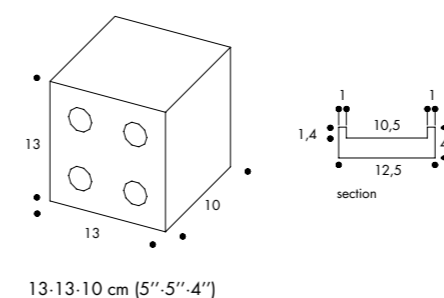

complementary pieces

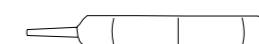
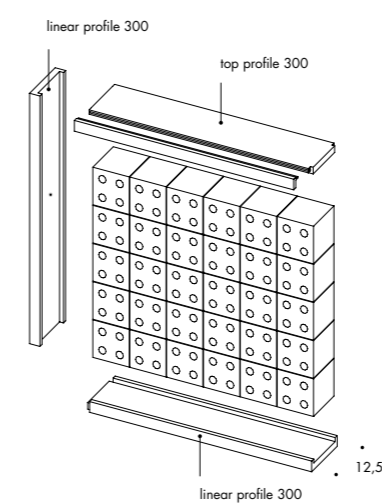

To make the installation of these items easier, a Mutina adhesive is now available: organic, eco-friendly and sold separately.

Tube Colors

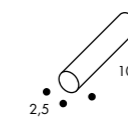

2,5-10 cm [1"-4"]

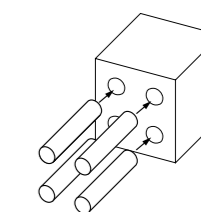

Blue Tube



Red Tube

ANCHORING ON 2 SIDES
Max h 400 cm

ANCHORING ON 3 SIDES
Max h 400x300 cm

ANCHORING ON 2 SIDES
MAX h250x100 cm

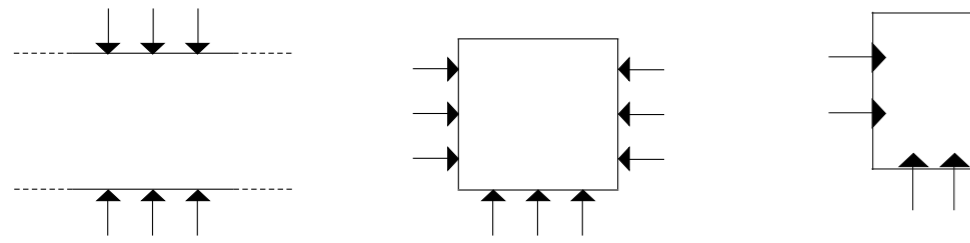

Laying and maintenance tips

use	Wall – indoor Wall – outdoor in moderate exposure areas for Bloc Natural only
installation	For installation process see the installation video available on www.mutina.it
recommended adhesive	Mutina adhesive: solvents-free, eco-friendly organic adhesive.
recommended joints	–
recommended fillers	–
cleaning at the end of installation	Avoid drippings during installation. If needed the excess can be removed after the product has dried, using a tool with a sharp edge.
general cleaning (installed tiles)	–
calibers (real size)	13 x 13 x 10 cm with 1-3 mm tolerance (artisanal product)

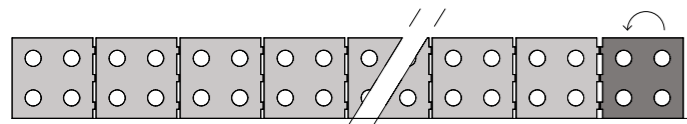

N.B.: When laying the blocks, always place the ribs on the same side, with the exception of the last block in the row.

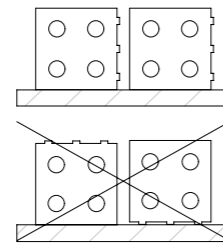

Never lay the blocks with the ribs facing upwards or downwards.

Colors

GLOSSY



Pearl Grey Red Blue

MAT



Pearl Grey Red Blue Natural

Technical features

STANDARD	FEATURES	VALUE REQUIRED	BLOC
UNI EN 772-16	dimensions	to declare	T2 – R2
UNI EN 772-21:2011	water absorption	to declare	12,5%
UNI EN 772-5:2016	content of active soluble salts	to declare	S2
UNI EN CEN/TS 772- 22:2006	freeze-thaw resistance	to declare	F1
D.M. 1401/2008	determination of horizontal variable loads	to declare	C2
LEED CERTIFICATION 4.1			10% recycled material
VOC Emission			available upon request
Declaration of Contents			available upon request
SDS			available upon request
BPD3			available upon request
HPD			available upon request

Packing

SIZE	PCS-SQM	PCS-PAL	PCS-BOX	BOX-PL	KG-BOX	KG-PC	KG-PAL	SQM-PAL
natural 5''-5''-4'' cm	59,17	96				2,85	273,60	1,62
other colors 5''-5''-4'' cm	59,17		4	48	11,40		547,20	3,24
tube			18		0,54	0,03		

Brac

The data, information and indications contained in this technical data sheet and in further documents relating to the Brac by Nathalie Du Pasquier product are the exclusive property by Ceramiche MUTINA S.p.a. This Technical Data Sheet provides the buyer with information relating to the use of the product useful for its correct installation and evaluation and prevention of risks arising from the normal use of the same.

collection	Brac
design	Nathalie Du Pasquier, 2019
production	Artisanal
material	Extruded terracotta
thickness	10 cm
nominal sizes	12,5x22x10 cm
specification	<ul style="list-style-type: none"> - artisanal extruded partition elements, 10cm thick. - 5 colours: Argilla (natural finishing), Bianco, Salvia, Marrone, Nero (glossy painted finishing) - 3 different laying patterns are possible (see attached document). <p>This product is suitable for both residential and commercial areas, to be installed in walls with height of 4mt. These elements must in any case comply with the technical standards of construction regulation, applicable in the country where they are installed. For the Italian national territory, in particular, they should comply with standard NTC 2018 DECRETO MIN 27/01.</p> <p>In order to achieve an optimal aesthetic outcome we advise to install BRAC using our wooden profile. The profile is painted and suitable for outdoor use. A top profile with removable sides is provided for ceiling fixing. As complementary pieces Mutina provide the Mutina adhesive, EC 1 plus for VOC emissions. For installation process see the installation video available on www.mutina.it</p> <p>Brac Argilla is suitable for indoor and outdoor areas complying with UNI EN 772-22 marked "F1- moderate exposure". Brac Bianco, Nero, Salvia and Marrone are suitable for indoor only.</p>
awards	Interior Design Magazine's Best of Year Awards 2020 in the Category Architectural Products
patents	Registered design n° 007510870-0041/0044 - date of registration: 14/01/2020
category	UNI 11128/2004

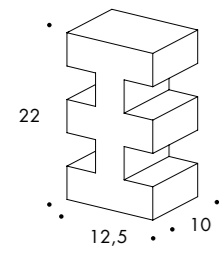

complementary pieces

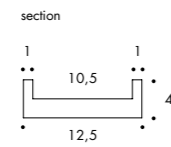
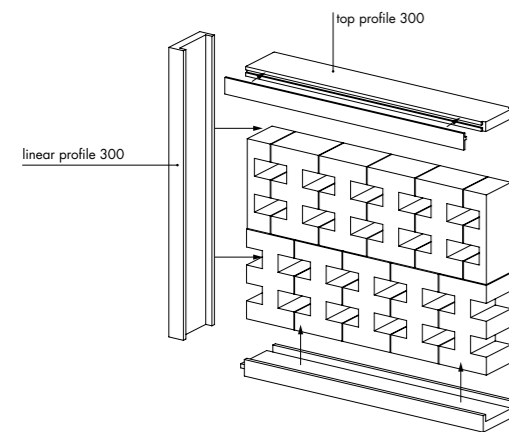

colors

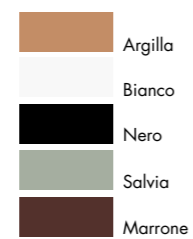

To make the installation of these items easier, a Mutina adhesive is now available: organic, eco-friendly and sold separately.



Scan the QR code to download the technical features in other languages

laying scheme

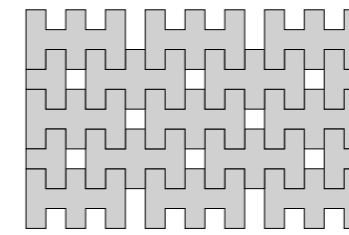

laying scheme 1
43,20 pcs / sqm

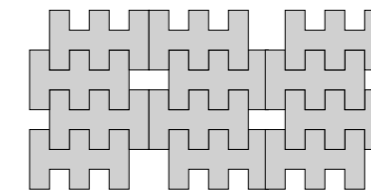

laying scheme 2
43,20 pcs / sqm

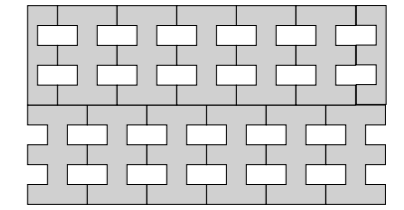

laying scheme 3
36 pcs / sqm

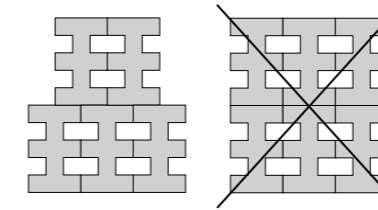

For security reasons only staggered installation is strictly allowed.

ANCHORING ON 2 SIDES

Max h 400 cm

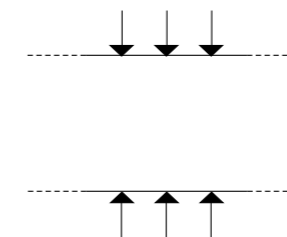

ANCHORING ON 3 SIDES

Max h 400x300 cm

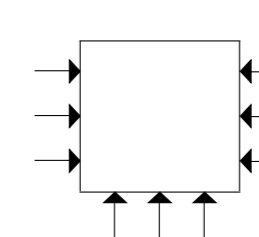

ANCHORING ON 2 SIDES

MAX h250x100 cm

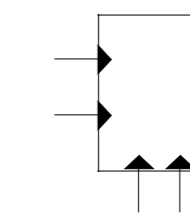

Laying and maintenance tips

use	Wall – indoor Wall – outdoor in moderate exposure areas for Brac Argilla only
installation	For security reasons only staggered installation is strictly allowed.
recommended adhesive	Mutina adhesive: solvents-free, eco-friendly organic adhesive.
recommended joints	–
recommended fillers	–
cleaning at the end of installation	Avoid drippings during installation. If needed the excess can be removed after the product has dried, using a tool with a sharp edge.
general cleaning (installed tiles)	–
calibers (real size)	12,5 x 22 x 10 cm with 1-3 mm tolerance (artisanal product)

Colors



Argilla



Bianco



Nero



Salvia



Marrone

Technical features

STANDARD	FEATURES	VALUE REQUIRED	BRAC
UNI EN 772-16	dimensions	to declare	T2-R2
UNI EN 772-21	water absorption	to declare	12,5%
UNI EN 772-5	soluble salts content	to declare	S2
UNI EN 772-22	freeze-thaw resistance	to declare	F1
D.M. 1401/2008	determination of variable horizontal loads	to declare	C2
Leed 4.1			10%
VOC Emission			available upon request
Declaration of Contents			available upon request
SDS			available upon request
BPD3			available upon request
HPD			available upon request

Packing

SIZE	PCS-SQM	PCS-BOX	SQM-PAL	PCS-PAL	KG-PC	KG-PAL
22-12,5-10 cm argilla		–	1,30	48	3,70	177,60
22-12,5-10 cm bianco,nero,salvia,marrone		3	3,91	48	3,70	532,80
Scheme 1	43,20					
Scheme 2	43,20					
Scheme 3	36					

Celosia

The data, information and indications contained in this technical data sheet and in further documents relating to the Celosia by Patricia Urquiola product are the exclusive property by Ceramiche MUTINA S.p.a. This Technical Data Sheet provides the buyer with information relating to the use of the product useful for its correct installation and evaluation and prevention of risks arising from the normal use of the same.

collection	Celosia
design	Patricia Urquiola, 2018
production	Artisanal
material	Extruded terracotta
nominal sizes	20,5-26,5-10 cm (8"-10"- 4")
specification	<ul style="list-style-type: none"> - Artisanal extruded partition elements, 10cm thick. - This product is suitable for both residential and commercial spaces to construct walls with a maximum height of 4 metres. The buyer is not released from the obligation of checking the information received, and for making design and construction choices in compliance with good construction techniques and regulations, including local ones, in force at the time of use of the product and in the country of final destination. The NTC 2018 DECRETO MIN 27/01 regulation shall apply in Italy. - In order to achieve an optimal aesthetic outcome we advise to install Celosia using our wooden profile. The profile is painted and suitable for outdoor use. A top profile with removable sides is provided for ceiling fixing. - As complementary pieces Mutina provide the Mutina adhesive, EC 1 plus for VOC emissions. - For installation process see the installation video available on www.mutina.it - The product is suitable for indoor and outdoor areas complying with UNI EN 772-22 marked "F1-moderate exposure".
complementary pieces	Linear profile 300, top profile 300.
awards	Interior Design's Best of Year 2018 German Design Awards 2020
category	UNI 11128/2004

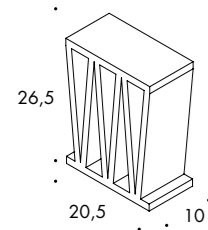

20,5-26,5-10 cm
8"-10"- 4"

complementary pieces

Linear painted willow profile (also suitable for outdoor use).
Top painted willow profile (also suitable for outdoor use) with one shaped end to make clamping easier.

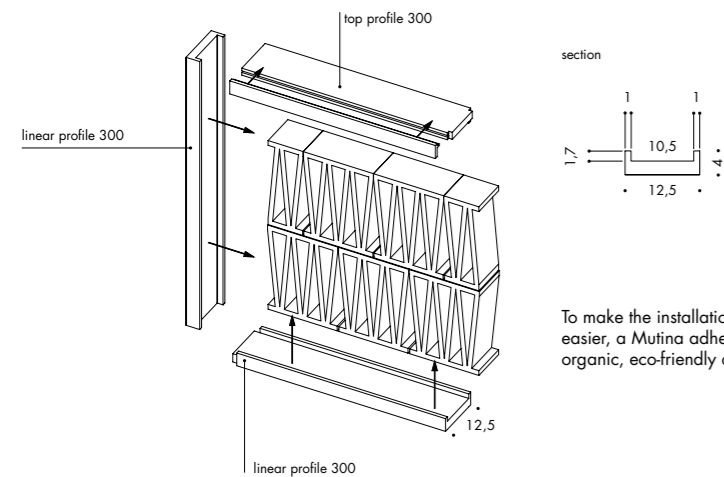

To make the installation of these items easier, a Mutina adhesive is now available: organic, eco-friendly and sold separately.



Scan the QR code to download the technical features in other languages

wall anchoring scheme

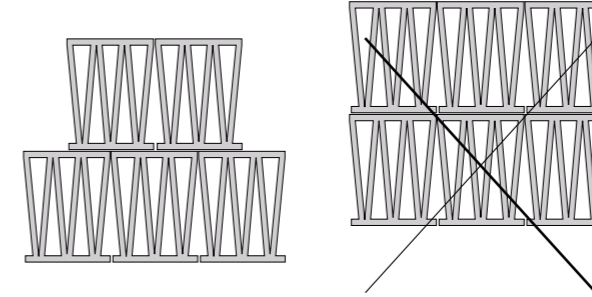

For security reasons only staggered installation is strictly allowed.

Standard installation suggestions have been tested by Mutina and certified by the Giordano Institute.

Fisher long shaft fixing SXR 8x80

ANCHORING ON 2 SIDES
Max h 400 cm

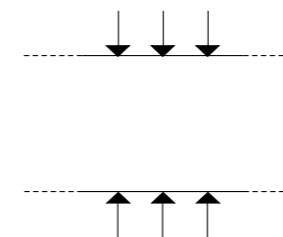

ANCHORING ON 3 SIDES
Max h 400x300 cm

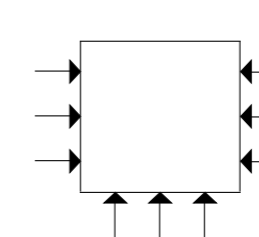

Laying and maintenance tips

use	Wall - indoor Wall - outdoor in moderate exposure areas only
installation	For security reasons only staggered installation is strictly allowed. For installation process see the installation video available on www.mutina.it
recommended adhesive	Mutina adhesive: solvents-free, eco-friendly organic adhesive
recommended joints	-
recommended fillers	-
cleaning at the end of installation	Avoid drippings during installation. If needed the excess can be removed after the product has dried, using a tool with a sharp edge.
general cleaning (installed tiles)	-
calibers (real size)	20,5 x 26,5 x 10 cm with 1-3 mm tolerance (artisanal product)

Colors



Technical features

STANDARD	FEATURES	VALUE REQUIRED	CELOSIA
UNI EN 772-16	dimensions	to declare	T2 – R2
UNI EN 772-21:2011	water absorption	to declare	12.5%
UNI EN 772-5:2016	content of active soluble salts	to declare	S2
UNI EN CEN/TS 772- 22:2006	freeze-thaw resistance	to declare	F1
D.M. 1401/2008	determination of horizontal variable loads	to declare	C2
LEED CERTIFICATION 4.1			10% recycled material
VOC EMISSION			available upon request
DECLARATION OF CONTENTS			available upon request
SDS			available upon request
BPD3			available upon request
HDP			available upon request

Packing

SIZE	PCS-SQM	PCS-PAL	SQM-PAL	KG-PC	KG-PAL
20,5-26,5-10 cm	18,41	32	1,74	5,50	176,00



Scan the QR code to download the technical features in other languages

Hives

The data, information and indications contained in this technical data sheet and in further documents relating to the Hives by Konstantin Grcic product are the exclusive property by Ceramiche MUTINA S.p.a. This Technical Data Sheet provides the buyer with information relating to the use of the product useful for its correct installation and evaluation and prevention of risks arising from the normal use of the same.

collection	Hives
design	Konstantin Grcic, 2022
production	Artisanal
material	Extruded terracotta
nominal sizes	13-22,5-7 cm [5"-9"-3"]
specification	<ul style="list-style-type: none"> – Artisanal extruded partition elements, 7cm thick. Natural (natural finishing) – It is possible to install Hives both horizontally and vertically. – For aesthetic outcome in vertical installation it is possible to install Hives using our wooden profile. The profile is painted and suitable for outdoor use. A top profile with removable sides is provided for ceiling fixing. – Horizontal installation: the product is suitable for both residential and commercial areas for the construction of walls with a maximum height of 4m. – Vertical installation: the product is suitable for residential areas with a maximum height of 3m. – These elements must in any case comply with the technical standards of construction regulation, applicable in the country where they are installed. – For the Italian national territory, in particular, they should comply with standard NTC 2018 DECRETO MIN 27/01. – As complementary pieces Mutina provide the Mutina adhesive, EC 1 plus for VOC emissions. <p>For installation process see the installation video available on www.mutina.it</p> <p>Hives is suitable for indoor and outdoor areas complying with UNI EN 772-22 marked "F1- moderate exposure".</p>
category	UNI 11128/2004

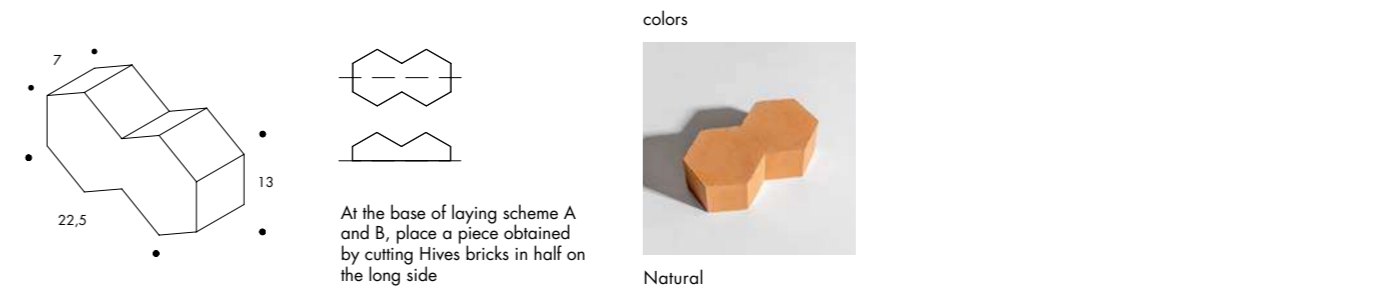

complementary pieces

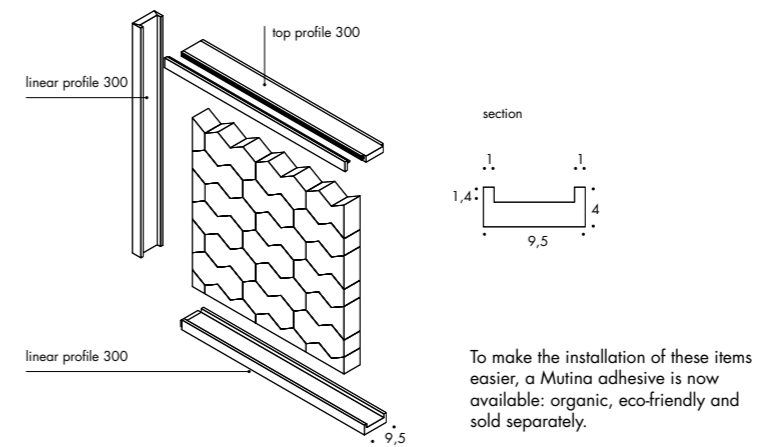

horizontal installation

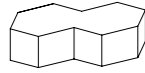

ANCHORING ON 2 SIDES
MAX h400 cm

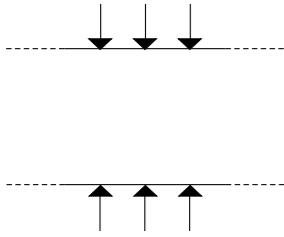

vertical installation

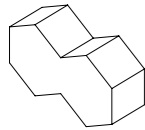

ANCHORING ON 4 SIDES
MAX h300x200 cm

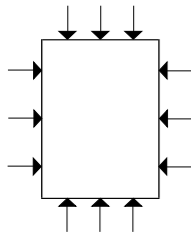

ANCHORING ON 2 SIDES
MAX h200x200 cm

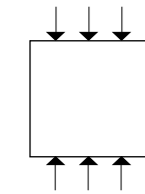

ANCHORING ON 3 SIDES
MAX h300x200 cm

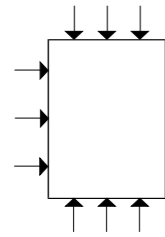

ANCHORING ON 2 SIDES
MAX h200x150 cm

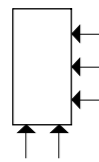

ANCHORING ON 3 SIDES
MAX h300x200 cm

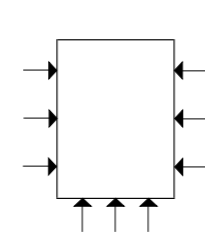

Laying and maintenance tips

use	Wall – indoor Wall – outdoor in moderate exposure areas only
installation	For installation process see the installation video available on www.mutina.it
cleaning at the end of installation	Avoid drippings during installation. If needed the excess can be removed after the product has dried, using a tool with a sharp edge.
calibers (real size)	22,5 x 13,1 x 7 cm with 1-3 mm tolerance (artisanal product)

Hives – laying scheme A
45 pcs / sqm

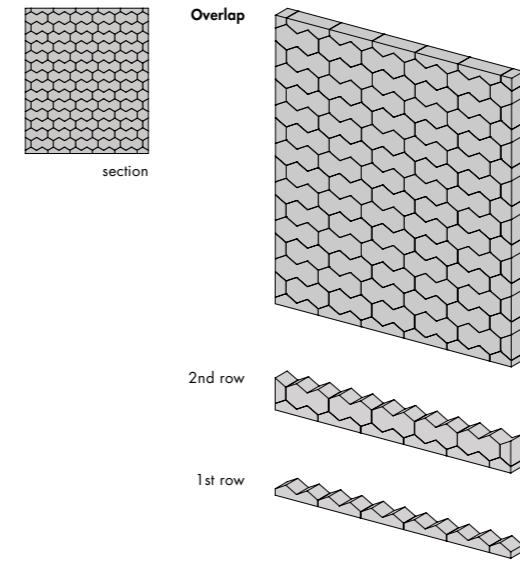

Hives – laying scheme B
30 pcs / sqm

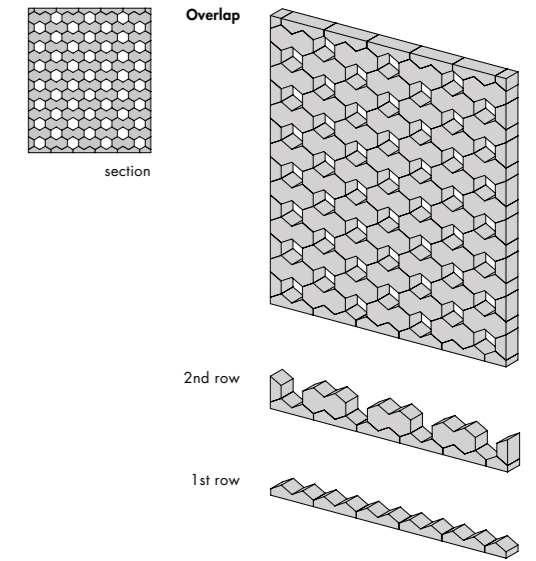

Hives – laying scheme C (Staggered installation only).
61 pcs / sqm

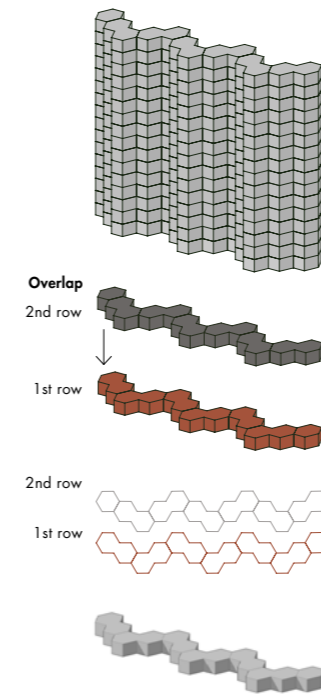

Hives – laying scheme D (Staggered installation only).
186 pcs / sqm

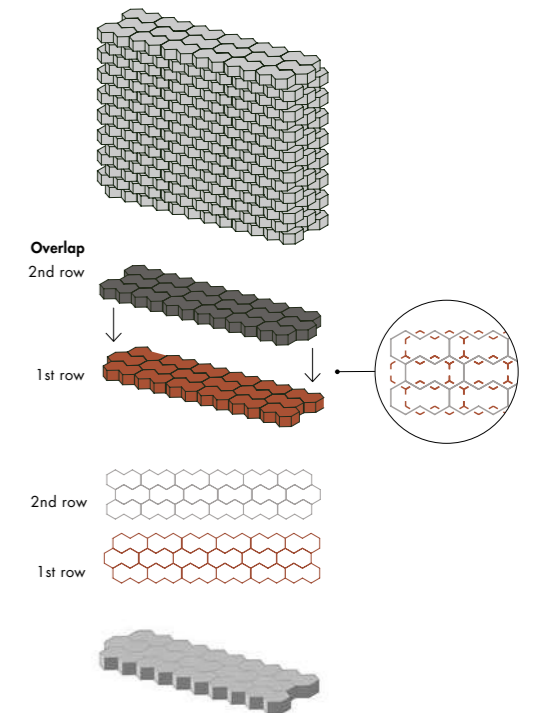

Hives – laying scheme E (Staggered installation only).
 61 pcs / sqm (side column)
 46 pcs / sqm (central area)

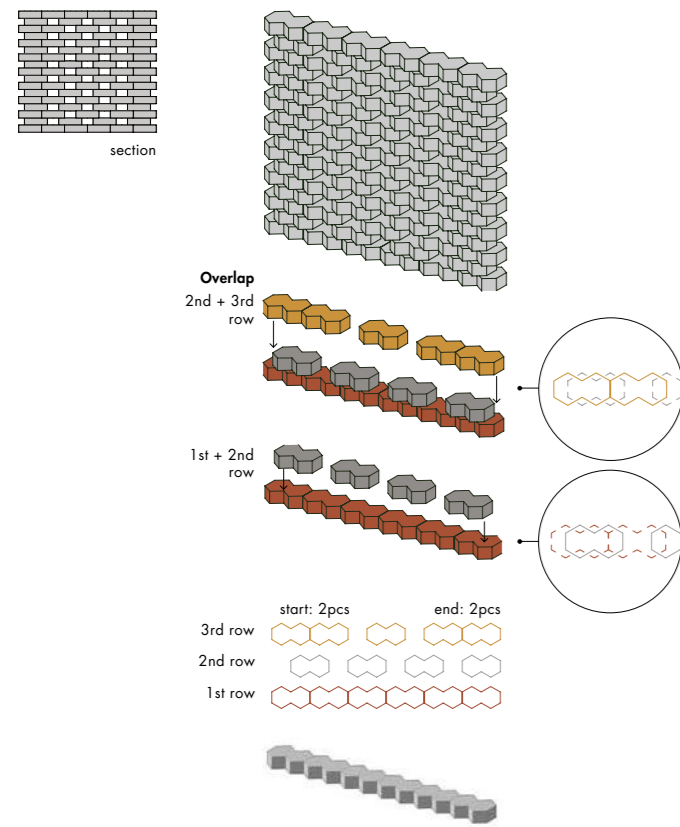

Hives – laying scheme F (Staggered installation only).
 61 pcs / sqm

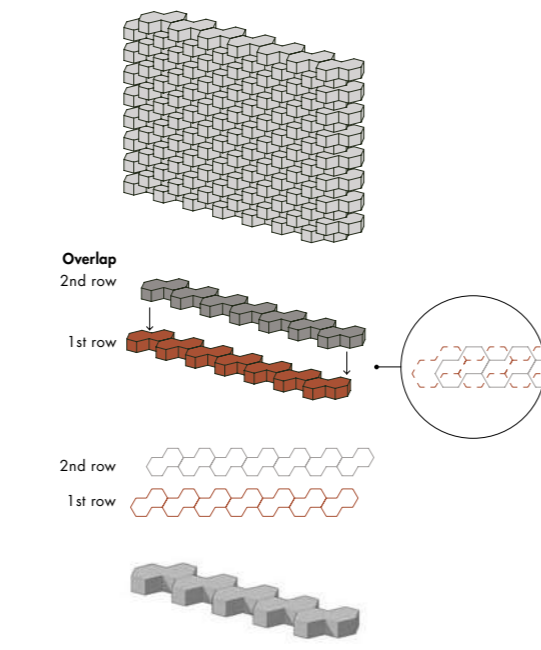

Hives – laying scheme G (Staggered installation only).
 84 pcs / 1m

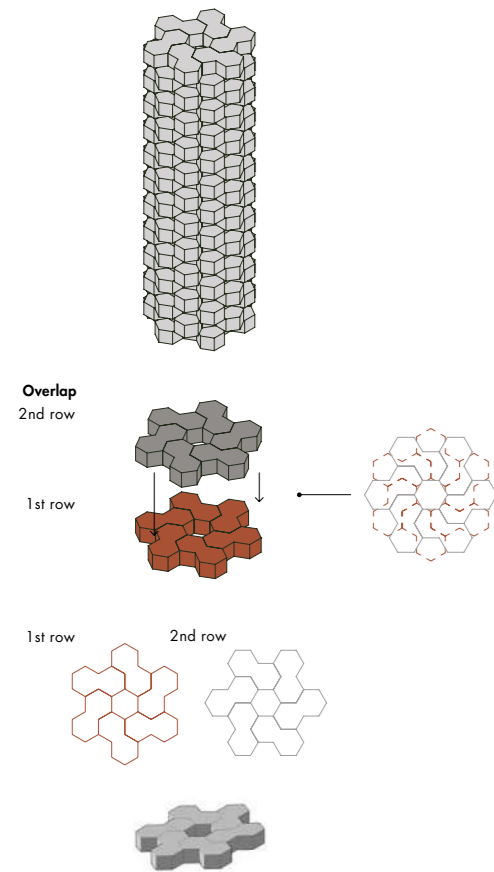

Hives – laying scheme H (Staggered installation only).
 84 pcs / 1m

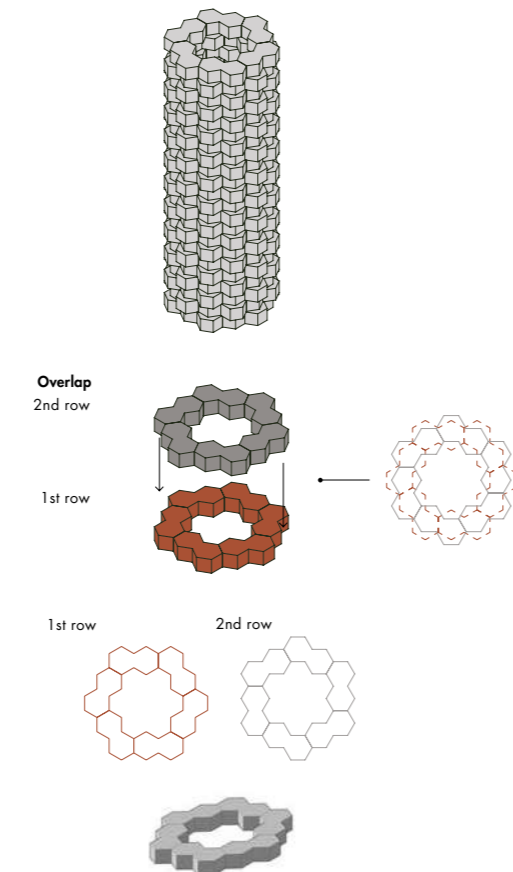

Technical features

STANDARD	FEATURES	VALUE REQUIRED	HIVES
UNI EN 772-16	dimensions	to declare	T2 – R2
UNI EN 772-21	water absorption	to declare	12,5%
UNI EN 772-5	content of active soluble salts	to declare	S2
UNI EN 772 - 22	freeze-thaw resistance	to declare	F1
D.M. 1401/2008	determination of horizontal variable loads	to declare	C2
LEED CERTIFICATION 4.1			10% recycled material
VOC Emission			available upon request
Declaration of Contents			available upon request
SDS			available upon request
BPD3			available upon request
HPD			available upon request

Packing

SIZE	SQM-PAL	KG-PAL	PCS-PAL	PC-SQM	KG-PC
13-22,5-7,5 cm	2,16	287,04	96	see laying scheme	2,99

Mistral

The data, information and indications contained in this technical data sheet and in further documents relating to the Mistral by Barber & Osgerby product are the exclusive property by Ceramiche MUTINA S.p.a. This Technical Data Sheet provides the buyer with information relating to the use of the product useful for its correct installation and evaluation and prevention of risks arising from the normal use of the same.

collection	Mistral
design	Barber & Osgerby, 2018
production	Artisanal
material	Glazed casting terracotta
nominal sizes	12,5-25,5-12,5 cm (4"-10"-4")
specification	<ul style="list-style-type: none"> - 3 colors pieces: White, Owl, Black - Wooden profile in 3 matching colors - Non structural artisanal partition elements, in tape casting terracotta, 12,5 cm thick. - The particular shape of Mistral allows until 8 different installation possibilities, vertical and horizontal, open and close. These elements must in any case comply with the technical standards of construction regulation, applicable in the country where they are installed. For the Italian national territory, in particular, they should comply with standard NTC 2018 DECRETO MIN 27/01. - The product is suitable for indoor and outdoor areas complying with UNI EN 772-22 marked "F2-extreme exposure". - Suitable for both residential and commercial areas, to be installed with painted willow profile with maximum surfaces of 2mt x 3mt or 3mt x 2mt. - The profile is painted and suitable for outdoor use. A top profile with removable sides is provided for ceiling fixing. - For installation process see the installation video available on www.mutina.it
complementary pieces	Linear profile 300, Top profile 300
category	-

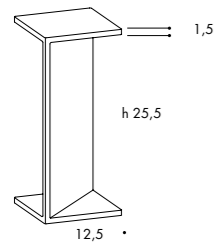

12,5-25,5-12,5 cm
4"-10"-4"

complementary pieces

Linear painted willow profile (also suitable for outdoor use).
Top painted willow profile (also suitable for outdoor use) with one shaped end to make clamping easier.

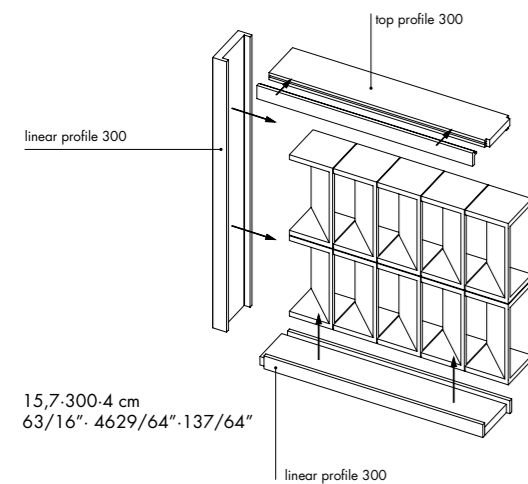

15,7-300-4 cm
63/16"-4629/64"-137/64"

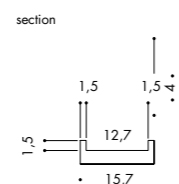

To make the installation of these items easier, a Mutina adhesive is now available: organic, eco-friendly and sold separately.



Scan the QR code to download the technical features in other languages

wall anchoring scheme

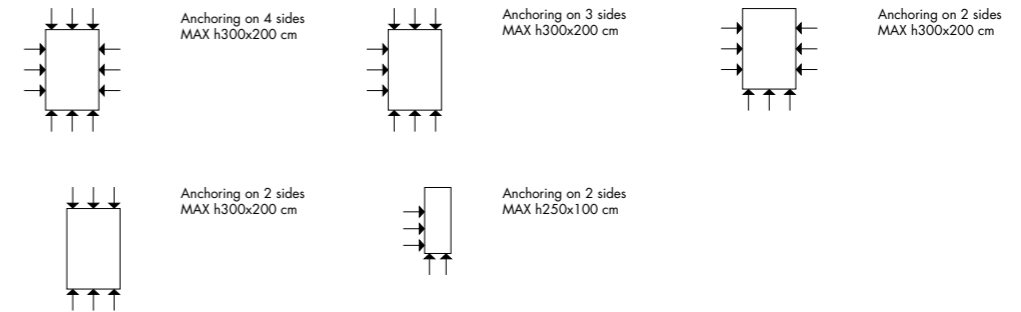

Fisher long shaft fixing SXR 8x80

Laying and maintenance tips

use	Wall – indoor, outdoor.
installation	For installation process see the installation video available on www.mutina.it
recommended adhesive	Mutina adhesive: solvents-free, eco-friendly organic adhesive
recommended joints	-
recommended fillers	-
cleaning at the end of installation	Avoid drippings during installation. If needed the excess can be removed after the product has dried using a tool with a sharp edge.
general cleaning (installed tiles)	-
calibers (real size)	12,5x25,5x12,5 cm with a tolerance of 2 mm (artisanal product)

Colors



Black



Owl



White

Technical features

STANDARD	FEATURES	VALUE REQUIRED	MISTRAL
UNI EN 772-16	dimensions	to declare	T2 – R2
UNI EN 772-21:2011	water absorption	to declare	1%
UNI EN 772-5:2016	content of active soluble salts	to declare	S0
UNI EN CEN/TS 772- 22:2006	freeze-thaw resistance	to declare	F2
D.M. 1401/2008	determination of horizontal variable loads	to declare	C2
LEED CERTIFICATION 4.1			5% recycled material
VOC Emission			available upon request
Declaration of Contents			available upon request
SDS			available upon request
BPD3			available upon request
HPD			available upon request

Packing

SIZE	PCS-SQM	PCS-BOX	SQM-BOX	BOX-PAL	KG-BOX	KG-PAL	SQM-PAL
12,5-25,5-12,5 cm	31,40	3	0,091	45	6,60	297,00	4,30



Scan the QR code to download the technical features in other languages

Renga

The data, information and indications contained in this technical data sheet and in further documents relating to the Renga by Vincent Van Duysen product are the exclusive property by Ceramiche MUTINA S.p.a. This Technical Data Sheet provides the buyer with information relating to the use of the product useful for its correct installation and evaluation and prevention of risks arising from the normal use of the same.

collection	Renga
design	Vincent Van Duysen, 2022
production	Artisanal
material	Glazed casting terracotta
nominal sizes	15x25x15 cm (6"x10"x6")
specification	<ul style="list-style-type: none"> - 3 colors: Ivory, Grey, Brown - Non structural artisanal partition elements - These elements must comply with the technical standards of construction regulation, applicable in the country where they are installed. For the Italian national territory, in particular, they should comply with standard NTC 2018 DECRETO MIN 27/01. - The product is suitable for indoor and outdoor areas complying with UNI EN 772-22 marked "F1-moderate exposure"

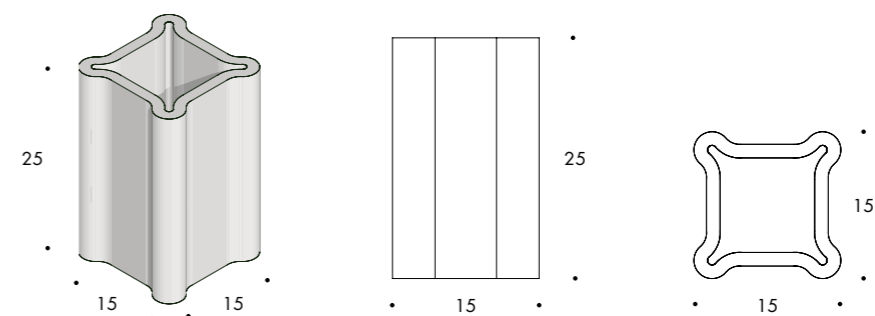

laying scheme

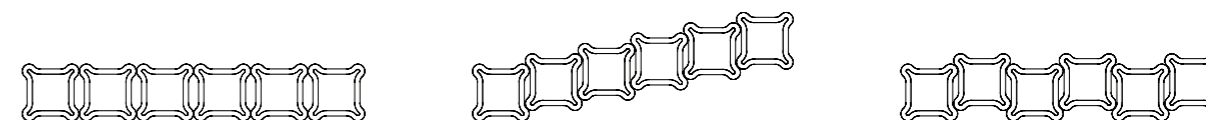

laying scheme 1
26,67 pcs / sqm

laying scheme 2
28,19 pcs / sqm

laying scheme 3
28,19 pcs / sqm

Laying and maintenance tips

use	Wall – indoor, outdoor.
installation	Insert a 50 mm wide "Murfor Compact" type reinforcing metal mesh between each horizontal row and along the entire length of the wall.
recommended adhesive	Solvents-free, eco-friendly organic adhesive produced by Kerakoll in exclusive for Mutina.
cleaning at the end of installation	Avoid drippings during installation. If needed the excess can be removed after the product has dried using a tool with a sharp edge.
general cleaning (installed tiles)	-
calibers (real size)	15 x 25 x 15 with a tolerance of 2 mm (artisanal product)

Colors



Ivory



Grey



Brown

Technical features

Non structural artisanal partition elements. These elements must in any case comply with the technical standards of construction regulation, applicable in the country where they are installed. For the Italian national territory, in particular, they should comply with standard NTC 2018 DECRETO MIN 27/01. This product is suitable for indoor and outdoor areas complying with UNI EN 722-22 marked "F1-moderate exposure".

STANDARD	FEATURES	VALUE REQUIRED	RENGA
UNI EN 772-16	dimensions	to declare	T2-R2
UNI EN 772-21:2011	water absorption	to declare	0,5%
UNI EN 772-5:2016	content of active soluble salts	to declare	S0
UNI EN CEN/TS 772- 22:2006	freeze-thaw resistance	to declare	F1
D.M. 1401/2008	determination of variable horizontal loads	to declare	C2

VOC Emission

Declaration of Contents

SDS

Packing

SIZE	PCS-SQM	PCS-BOX	SQM-PAL	BOX-PAL	KG-PC	KG-PAL
15-25-15 cm	see laying scheme	2	4,275	57	8.30	473,10

EDITIONS

El Lobo

collection	El Lobo
design	Patricia Urquiola, 2022
production	Artisanal
material	Object in glazed black body made by slip-casting
features	Each piece is handmade in Italy, stamped and signed in a sequential manner
sizes	6,5 x 40 x h32 cm (3" x 16" x h13")
weight	1,9 Kg
colors	



El Lobo Whisky



El Lobo Nero

Packing

	SIZE	GROSS WEIGHT
wooden packaging	42-52 cm-h 15 cm 16 ^{17/32"} . 20 ^{15/32"} . h 5 ^{29/32"}	7,9 Kg

Paesaggi

collection	Paesaggi
design	Nathalie Du Pasquier, 2022
production	Artisanal
material	Object designed for interior decoration, produced by manual casting, refined and enameled with the "tuffatura" technique
features	Each piece is handmade in Italy, stamped and signed in a sequential manner
sizes	Tondo - Ø 40 cm (Ø 16") Quadrato - 40 x 40 cm (16" x 16") Rettangolo - 40 x 60 cm (16" x 24")
weight	Tondo (6 Kg), Quadrato (6 Kg), Rettangolo (8 Kg)
colors	



Tondo Bianco



Tondo Verde



Tondo Policromo



Quadrato Bianco



Quadrato Rosso



Quadrato Policromo



Rettangolo Bianco



Rettangolo Nero



Rettangolo Policromo

Packing

	SIZE	GROSS WEIGHT
Tondo wooden packaging	60-47 cm-h 43 cm 23 ^{5/8"} . 18 ^{1/2"} . h 16 ^{59/64"}	16 Kg
Quadrato wooden packaging	60-47 cm-h 43 cm 23 ^{5/8"} . 18 ^{1/2"} . h 16 ^{59/64"}	16 Kg
Rettangolo wooden packaging	78-49 cm-h 43 cm 30 ^{45/64"} . 19 ^{19/64"} . h 16 ^{59/64"}	20 Kg

Phenomenon Plate

collection	Phenomenon Plate
design	Tokujiin Yoshioka, 2022
production	Artisanal
material	Object in glazed porcelain stoneware made by slip-casting
features	Each piece is handmade in Italy, stamped and signed in a sequential manner
sizes	Ø 34 x h2 cm (Ø 13" x h1")
weight	1,75 Kg
colors	



Phenomenon Plate

Packing

	SIZE	GROSS WEIGHT
wooden packaging	44.48 cm-h 10 cm 17 ^{21/64"} · 18 ^{57/64"} · h 3 ^{15/16}	5,75 Kg

Rombini Vases

collection	Rombini Vases
design	Ronan & Erwan Bouroullec, 2021
production	Artisanal
material	Handcrafted ceramic vase covered with the elements Rombini Triangle Extra Small
features	Each piece is handmade in Italy, stamped and signed in a sequential manner
sizes	Vase A – Ø 16,3 cm x h37 cm (Ø 6 ^{27/64"} x h14 ^{9/16"}) Vase B – Ø 24,8 cm x h71,2 cm (Ø 9 ^{49/64"} x h28") Vase C – Ø 24,8 cm x h71,2 cm (Ø 9 ^{49/64"} x h28")
weight	Vase A (6 Kg), Vase B (15 Kg), Vase C (12 Kg)
colors	



Rombini Vase A Glossy Blanc



Rombini Vase A Glossy Brun



Rombini Vase A Glossy Vert



Rombini Vase A Vert + Rose



Rombini Vase A Rose + Brun



Rombini Vase A Glossy Gris + Vert



Rombini Vase B Glossy Brun + Rose



Rombini Vase B Glossy Brun + Matt Blue



Rombini Vase B Glossy Vert



Rombini Vase C Glossy Vert + Brun



Rombini Vase C Glossy Brun + Rose + Vert



Rombini Vase C Glossy Rose + Matt White + Matt Grey

Packing

	SIZE	GROSS WEIGHT
Rombini Vase A wooden packaging	47.29,5 cm-h 27 cm 18 ^{1/2"} · 11 ^{39/64"} · h 10 ^{5/8"}	12,4 Kg
Rombini Vase B wooden packaging	81 x 37 cm - h 39 cm 31 ^{57/64"} · 14 ^{9/16"} · h 15 ^{23/64"}	27,8 Kg
Rombini Vase C wooden packaging	81 x 37 cm - h 39 cm 31 ^{57/64"} · 14 ^{9/16"} · h 15 ^{23/64"}	24,8 Kg

collection	Yama
design	Vincent Van Duysen, 2022
production	Artisanal
material	Objects in porcelain stoneware made by slip-casting
features	Each piece is handmade in Italy, stamped and signed in a sequential manner
sizes	Yama A – 18 x 33 x h18 cm (7" x 13" x h7") Yama B – 35 x 33 x h18 cm (14" x 13" x h7") Yama C – 35 x 33 x h35 cm (14" x 13" x h14") Yama D – 35 x 33 x h35 cm (14" x 13" x h14") Yama E – 35 x 33 x h35 cm (14" x 13" x h14")
weight	Yama A (1,25 Kg), Yama B (2,25 Kg), Yama C (3 Kg), Yama D (4 Kg), Yama E (5 Kg)
colors	



Yama A



Yama B



Yama C



Yama D



Yama E

PAINTS

Packing

	SIZE	GROSS WEIGHT
Yama A wooden packaging	49-53 cm-h 27 cm 19 ^{19/64"} -20 ^{55/64"} -h 10 ^{5/8"}	11,25 Kg
Yama B wooden packaging	49-53 cm-h 27 cm 19 ^{19/64"} -20 ^{55/64"} -h 10 ^{5/8"}	12,25 Kg
Yama C wooden packaging	49-53 cm-h 42 cm 19 ^{19/64"} -20 ^{55/64"} -h 16 ^{17/32"}	15 Kg
Yama D wooden packaging	49-53 cm-h 42 cm 19 ^{19/64"} -20 ^{55/64"} -h 16 ^{17/32"}	16 Kg
Yama E wooden packaging	49-53 cm-h 42 cm 19 ^{19/64"} -20 ^{55/64"} -h 16 ^{17/32"}	17 Kg

Accents Paints

Accents aims at redefining the approach to the world of interior design starting from surfaces.

collection	Accents
design	OEO Studio
material	Paints



Scan the QR code to download the technical features in other languages

20 colors **MATT** super matt water-based paint **SATIN** wall gloss super washable emulsion



6 colors **LIMETOUCH** colored lime-based decorative coating



LIMETOUCH complementary products

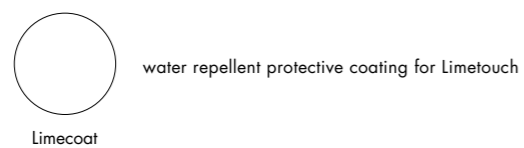

Uses and yields

	DESCRIPTION		YIELD*	DILUTION	IDEAL USE*
MATT	super matt water-based paint	new wall, civil plaster	7÷8 sqm/l in two coats	50% drinkable water for light colors 20-25% for strong colors	interior walls, especially living areas and bedrooms
		new wall, gypsum plaster	9÷11 sqm/l in two coats		
SATIN	wall gloss 100% washable emulsion		9÷11 sqm/l in two coats	20-25 % drinkable water	interior walls, especially when subject to abrasion or dirt (bathrooms, kitchen,...)
LIMETOUCH	colored lime-based decorative coating		1÷1,5 kg/sqm in two coats	-	Interior walls, especially ventilated environments (the usage in bathroom and kitchen is recommended only pairing with Limecoat)
LIMEBASE	pigmented primer for Limetouch		14÷18 sqm/l in one coat	50-80 % drinkable water	Interior walls when Limetouch has to be applied
LIMECOAT	water repellent protective coating for Limetouch		11÷13 sqm/l in two coats	-	Interior walls of humid environments when subject to dirt such as bathrooms or kitchens, when Limetouch is applied.

*considering that the conditions of the substrate can significantly influence the yield, to calculate the yield in an optimal way it is advisable to consider the lowest value

*avoid direct contact with beating water (e.g. shower enclosure walls)

Margherita Paints

collection	Margherita Paints
design	Nathalie Du Pasquier, 2020
production	Industrial



Scan the QR code to download the technical features in other languages

5 colors **MATT** super matt water-based paint **SATIN** wall gloss super washable emulsion



Uses and yields

	DESCRIPTION		YIELD*	DILUTION	IDEAL USE*
MATT	super matt water-based paint	new wall, civil plaster	7÷8 sqm/l in two coats	50% drinkable water for light colors 20-25% for strong colors	interior walls, especially living areas and bedrooms
		new wall, gypsum plaster	9÷11 sqm/l in two coats		
SATIN	wall gloss 100% washable emulsion		9÷11 sqm/l in two coats	20-25 % drinkable water	interior walls, especially when subject to abrasion or dirt (bathrooms, kitchen,..)

*considering that the conditions of the substrate can significantly influence the yield, to calculate the yield in an optimal way it is advisable to consider the lowest value

*avoid direct contact with beating water (e.g. shower enclosure walls)

WOOD & METAL

Accents Wood & Metal

Accents aims at redefining the approach to the world of interior design starting from surfaces.

collection	Accents
design	OEO Studio
material	Wood / Metal



Scan the QR code to download the technical features in other languages



L PROFILE HORIZONTAL
Aluminium profile powder coating
2,5 x 2,5 x 100 (L) cm



L PROFILE CORNER
Aluminium profile powder coating
2,5 x 2,5 x 100 (L) cm

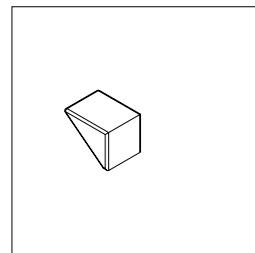

L CAP HORIZONTAL
Shaped wedge in resin for corner protection – Resin Black / Grey
2 x 2,5 x 1,9 (H) cm

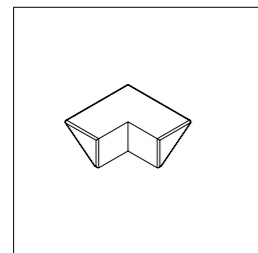

L CAP CORNER
Small sharp-edged wedge in resin for corner protection – Resin Black / Grey
4,8 x 2,5 x 1,9 (H) cm

finishing



Grey (RAL 7047)



Black (RAL 9004)



WALL PANEL CORNER 100
Light oak
1,5 x 10 x 100 (H) cm



WALL PANEL CORNER 160
Light oak
1,5 x 10 x 160 (H) cm

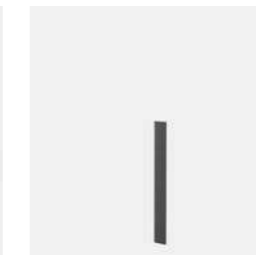

WALL PANEL CORNER 100
Dark oak
1,5 x 10 x 100 (H) cm

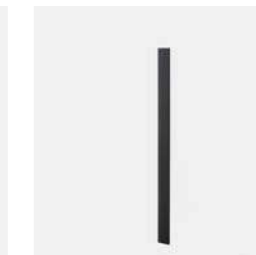

WALL PANEL CORNER 160
Dark oak
1,5 x 10 x 160 (H) cm

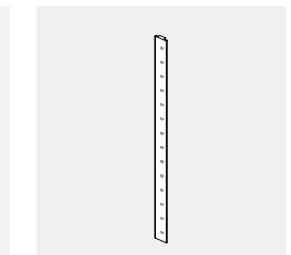

MOUNTING PIECE 100
Raw wood
0,9 x 3,7 x 100 (H) cm



WALL PANEL 100
Light oak
2 x 19,8 x 100 (H) cm



WALL PANEL 160
Light oak
2 x 19,8 x 160 (H) cm

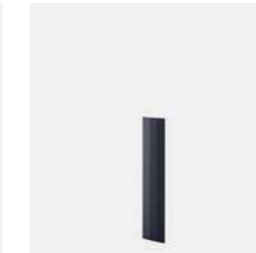

WALL PANEL 100
Dark oak
2 x 19,8 x 100 (H) cm



WALL PANEL 160
Dark oak
2 x 19,8 x 160 (H) cm

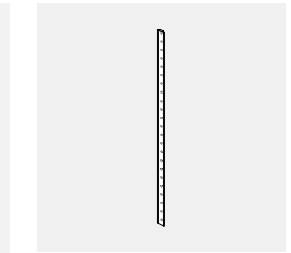

MOUNTING PIECE 160
Raw wood
0,9 x 3,7 x 160 (H) cm

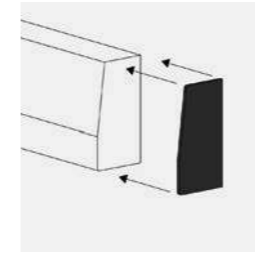

END PIECE S
Black painted metal
3 x 6 (H) x 0,2 (L) cm



SKIRTING S
Light oak
3 x 6 (H) x 240 (L) cm



SKIRTING S
Dark oak
3 x 6 (H) x 240 (L) cm



END PIECE L
Black painted metal
2,5 x 19,8 (H) x 0,2 (L) cm



SKIRTING L
Light oak
2,5 x 19,8 (H) x 240 (L) cm



SKIRTING L
Dark oak
2,5 x 19,8 (H) x 240 (L) cm

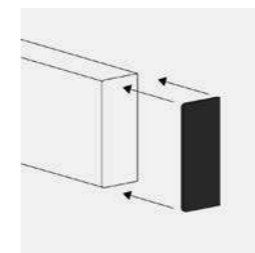

END PIECE RECTANGULAR
Black painted metal
2,5 x 6 (H) x 0,2 (L) cm



RECTANGULAR SKIRTING
Light oak
2,5 x 6 (H) x 240 (L) cm



RECTANGULAR SKIRTING
Dark oak
2,5 x 6 (H) x 240 (L) cm

Pico Bois

collection	Pico Bois
design	Ronan & Erwan Bouroullec, 2021
production	Industrial
material	Natural oak wood
thickness	14 mm
sizes	7x49 cm (3" - 19")
specification	- 2 textures: Red dots, Blue dots The modules are rated with an innovative embossing process. The painting treatment of the entire strip is made with a water-based single-component.
use	Floor - indoor
patents	Registered design n° 009069826 - 001/0008 - date of registration: 27/06/2022

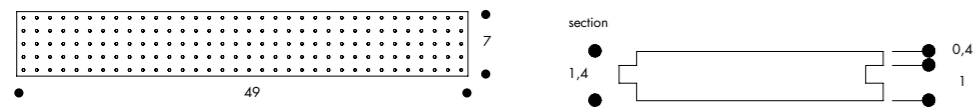

Colors

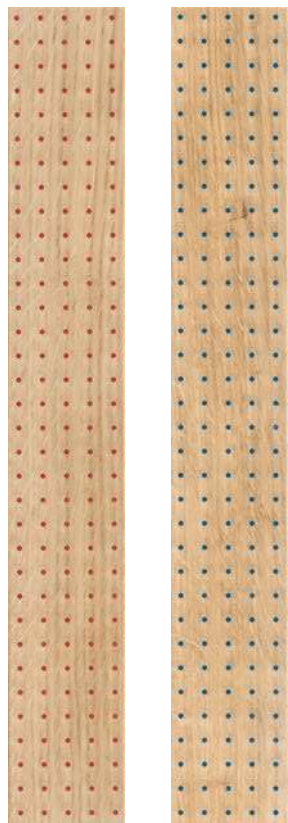

RED DOTS

BLUE DOTS



Scan the QR code to download the technical features in other languages

Technical features

STANDARD	FEATURES	VALUE REQUIRED	PICO BOIS
UNI EN 15185:2011	taber abrasion		408
UNI CEN/TS 15676:2008	slip resistance		75

PICO BOIS is a noble, high quality parquet (category A) and is FSC 100% certified.

Packing

SIZE	PCS-SQM	PCS-BOX	SQM-BOX	BOX-PAL	KG-BOX	KG-PAL	SQM-PAL
7-49 cm	29,15	16	0,55	72,00	4,95	356,40	39,60



Scan the QR code to
download the technical
features in other languages

Accents Accessories

Accents aims at redefining the approach to the world of interior design starting from surfaces.

collection Accents

design OEO Studio

material Mixed materials

ACCESSORIES



CABINET LARGE
Dark oak + Vegetable tanned leather
14,7 x 48 x 40,5 (H) cm



CABINET LARGE
Light oak + Vegetable tanned leather
14,7 x 48 x 40,5 (H) cm



CABINET SMALL
Dark oak + Vegetable tanned leather
14,7 x 48 x 17,5 (H) cm



CABINET SMALL
Light oak + Vegetable tanned leather
14,7 x 48 x 17,5 (H) cm



MIRROR LARGE
Dark oak
2 x 62 x 142 (H) cm



MIRROR LARGE
Light oak
2 x 62 x 142 (H) cm

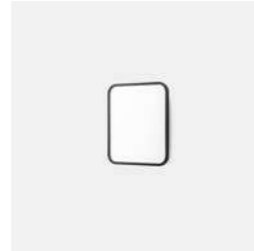

MIRROR SMALL
Dark oak
2 x 42 x 50 (H) cm



MIRROR SMALL
Light oak
2 x 42 x 50 (H) cm



RACK 72
Dark oak
2,5 x 6 (H) x 72 (L) cm



RACK 72
Light oak
2,5 x 6 (H) x 72 (L) cm



RACK 192
Dark oak
2,5 x 6 (H) x 192 (L) cm



RACK 192
Light oak
2,5 x 6 (H) x 192 (L) cm



SHELF SMALL
Dark oak
2,5 x 23 x 60 (L) cm



SHELF SMALL
Light oak
2,5 x 23 x 60 (L) cm



SHELF LARGE
Dark oak
2,5 x 23 x 120 (L) cm



SHELF LARGE
Light oak
2,5 x 23 x 120 (L) cm



TOWEL RACK LARGE
Black metal + Vegetable tanned leather
40,5 (H) cm x 95 (L) cm



TOWEL RACK TALL
Black metal + Vegetable tanned leather
53,4 (H) cm x 47 (L) cm

**You can
only work
with people
you like**

Milton Glaser

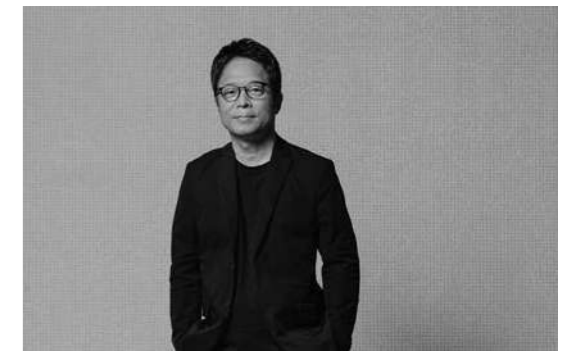

El Lobo rappresenta la nostra essenza.
El Lobo è Mutina.

“El Lobo per me è Massimo, energico capo branco di Mutina. Grande intuito e un fiuto acutissimo. La tigre e il leone possono essere i più forti però il lupo non si esibisce al circo. È un animale protettivo, capace di dare grande libertà agli altri credendo nella forza del branco. Viva il lupo!”

Patricia Urquiola

El Lobo represents our essence.
El Lobo is Mutina.

“To me, El Lobo is Massimo, energy leader of the pack of Mutina. Strong intuition and an acute sense of smell. The tiger and the lion may be the strongest ones, but the wolf doesn't perform at the circus. It's a protective animal, capable of giving great freedom to those who believe in the strength of the pack. Long live the wolf!”

Patricia Urquiola



Thank you!

To all past and present members of the Mutina team.
To all the designers, artists, writers, photographers, journalists,
agents, clients, partners, family and friends who have
made us who we are today.

CREDITS

Art direction: Alla Carta Studio
Graphic design: Matteo Pastorio, Erica Pizzetti
Text: Mutina
Photography: Studio Bouroullec,
Modofotografia, Depasquale+Maffini,
DSL Studio, Claudia Ferri, Gerhardt Kellermann,
Alessandro Paderni/EYE Studio, Matteo Pastorio,
Piergiorgio Sorgetti, Federico Torra,
Stefania Zanetti, Claudia Zalla.
Images: Officine Mimesi, Germano Schillaci.
Set design: Simona Bernardi, Leandro Favalaro,
Dimitra Louana Marlanti, Alessandro Mensi,
Sonia Pravato, Marco Viola Studio.
Featured projects: pag.317 Bistro Bacchus
(project by 'true. food agency', photography by
Evenbeeld), pag.21-318 Yara Valley House (project
by Chelsea Hing photography by Sean Fennessy).
Printed and bound in Italy. January 2023.

All the rights are reserved.
Not any part of this work can be reproduced in any
way without the preventive written authorization
by Mutina. All work is copyrighted © to their
respective owners.

To discover more about Mutina
collections visit mutina.it

Ceramiche Mutina Spa
Via del Crociale 25
41042 Fiorano Modenese, Italia
T +39 0536812800
F +39 0536812808
info@mutina.it
www.mutina.it

© Mutina 2023

Barber & Osgerby
Ronan & Erwan Bouroullec
Nathalie Du Pasquier
Konstantin Grcic
Hella Jongerius
Laboratorio Avallone
OEO Studio
Raw Edges
Inga Sempé
Patricia Urquiola
Vincent Van Duysen
Tokujiin Yoshioka